

## Productivity Series 32

---

From:

# Six Sigma for Quality and Productivity Promotion

©APO 2003, ISBN: 92-833-1722-X

by Sung H. Park

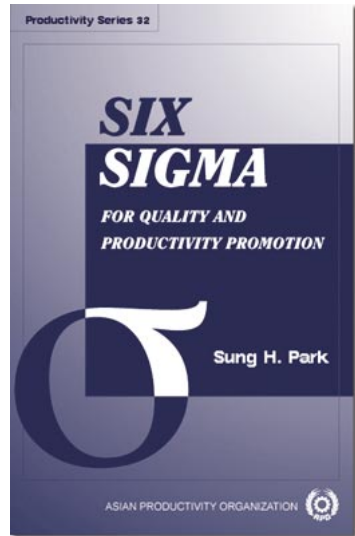

**Published by the Asian Productivity Organization**

1-2-10 Hirakawacho, Chiyoda-ku, Tokyo 102-0093, Japan

**Tel:** (81-3) 5226 3920 • **Fax:** (81-3) 5226 3950

**E-mail:** apo@apo-tokyo.org • **URL:** www.apo-tokyo.org

## Disclaimer and Permission to Use

This publication is provided in PDF format for educational use. It may be copied and reproduced for personal use only. For all other purposes, the APO's permission must first be obtained.

The responsibility for opinions and factual matter as expressed in this document rests solely with its author(s), and its publication does not constitute an endorsement by the APO of any such expressed opinion, nor is it affirmation of the accuracy of information herein provided.

Bound editions of the publication may be available for limited purchase. Order forms may be downloaded from the APO's web site.

**SIX**

**SIGMA**

***FOR QUALITY AND  
PRODUCTIVITY PROMOTION***

**Sung H. Park**

# ***SIX SIGMA***

***FOR QUALITY AND  
PRODUCTIVITY PROMOTION***

**Sung H. Park**

2003

ASIAN PRODUCTIVITY ORGANIZATION

© Asian Productivity Organization, 2003  
ISBN: 92-833-1722-X

The opinions expressed in this publication do not necessarily reflect the official view of the APO. For reproduction of the contents in part or in full, the APO's prior permission is required.

# TABLE OF CONTENTS

<b>Preface</b> .....	v
<b>1. Six Sigma Overview</b>	
1.1 What is Six Sigma? .....	1
1.2 Why is Six Sigma Fascinating? .....	2
1.3 Key Concepts of Management .....	5
1.4 Measurement of Process Performance .....	11
1.5 Relationship between Quality and Productivity ..	27
<b>2. Six Sigma Framework</b>	
2.1 Five Elements of the Six Sigma Framework ....	30
2.2 Top-level Management Commitment and Stakeholder Involvement .....	31
2.3 Training Scheme and Measurement System ....	34
2.4 DMAIC Process .....	37
2.5 Project Team Activities .....	41
2.6 Design for Six Sigma .....	45
2.7 Transactional/Service Six Sigma .....	48
<b>3. Six Sigma Experiences and Leadership</b>	
3.1 Motorola: The Cradle of Six Sigma .....	51
3.2 General Electric: The Missionary of Six Sigma ..	54
3.3 Asea Brown Boveri: First European Company to Succeed with Six Sigma .....	56
3.4 Samsung SDI: A Leader of Six Sigma in Korea ..	60
3.5 Digital Appliance Company of LG Electronics: Success Story with Six Sigma .....	67

**4. Basic QC and Six Sigma Tools**

4.1 The 7 QC Tools . . . . . 74  
4.2 Process Flowchart and Process Mapping . . . . . 85  
4.3 Quality Function Deployment (QFD) . . . . . 88  
4.4 Hypothesis Testing . . . . . 96  
4.5 Correlation and Regression . . . . . 99  
4.6 Design of Experiments (DOE) . . . . . 104  
4.7 Failure Modes and Effects Analysis (FMEA) . . . 112  
4.8 Balanced Scorecard (BSC) . . . . . 118

**5. Six Sigma and Other Management Initiatives**

5.1 Quality Cost and Six Sigma . . . . . 122  
5.2 TQM and Six Sigma . . . . . 126  
5.3 ISO 9000 Series and Six Sigma . . . . . 129  
5.4 Lean Manufacturing and Six Sigma . . . . . 131  
5.5 National Quality Awards and Six Sigma . . . . . 134

**6. Further Issues for Implementation of Six Sigma**

6.1 Seven Steps for Six Sigma Introduction . . . . . 136  
6.2 IT, DT and Six Sigma . . . . . 138  
6.3 Knowledge Management and Six Sigma . . . . . 143  
6.4 Six Sigma for e-business . . . . . 146  
6.5 Seven-step Roadmap for Six Sigma  
Implementation . . . . . 147

**7. Practical Questions in Implementing Six Sigma**

7.1 Is Six Sigma Right for Us Now? . . . . . 151

7.2 How Should We Initiate Our Efforts for Six Sigma? . . . . . 153

7.3 Does Six Sigma Apply Well to Service Industries? . . . . . 155

7.4 What is a Good Black Belt Course? . . . . . 156

7.5 What are the Keys for Six Sigma Success? . . . . 160

7.6 What is the Main Criticism of Six Sigma? . . . . 162

**8. Case Studies of Six Sigma Improvement Projects**

8.1 Manufacturing Applications: Microwave Oven Leakage . . . . . 165

8.2 Non-manufacturing Applications: Development of an Efficient Computerized Control System . . 172

8.3 R&D Applications: Design Optimization of Inner Shield of Omega CPT . . . . . 178

**Appendices**

Table of Acronyms . . . . . 187

A-1 Standard Normal Distribution Table . . . . . 189

A-2  $t$ -distribution Table of  $t(f;a)$  . . . . . 190

A-3  $F$ -distribution Table of  $F(f_1, f_2;a)$  . . . . . 191

A-4 Control Limits for Various Control Charts . . . . . 195

A-5 GE Quality 2000: A Dream with a Great Plan . . 196

References . . . . . 200

**Index** . . . . . 203



## PREFACE

---

This book has been written primarily for company managers and engineers in Asia who wish to grasp Six Sigma concepts, methodologies, and tools for quality and productivity promotion in their companies. However, this book will also be of interest to researchers, quality and productivity specialists, public sector employees, students and other professionals with an interest in quality management in general.

I have been actively involved over the last 20 years in industrial statistics and quality management teaching and consultation as a professor and as a private consultant. Six Sigma was recently introduced into Korea around 1997, and I have found that Six Sigma is extremely effective for quality and productivity innovation in Korean companies. I have written two books on Six Sigma in Korean; one titled “The Theory and Practice of Six Sigma,” and the other called “Design for Six Sigma,” which are both best-sellers in Korea. In 2001, I had the honor of being invited to the “Symposium on Concept and Management of Six Sigma for Productivity Improvement” sponsored by the Asian Productivity Organization (APO) during 7–9 August as an invited speaker. I met many practitioners from 15 Asian countries, and I was very much inspired and motivated by their enthusiasm and desire to learn Six Sigma. Subsequently, Dr. A.K.P. Mochtan, Program Officer of the Research & Planning Department, APO, came to me with an offer to write a book on Six Sigma as an APO publication. I gladly accepted his offer, because I wanted to share my experiences of Six Sigma with engineers and researchers in Asian countries, and I also desired a great improvement in quality and productivity in Asian countries to attain global competitiveness in the world market.

This book has three main streams. The first is to introduce an overview of Six Sigma, framework, and experiences (Chapters 1–3). The second is to explain Six Sigma tools, other management initiatives and some practical issues related to Six Sigma (Chapters 4–6). The third is to discuss practical questions in implementing Six Sigma and to present real case studies of

improvement projects (Chapters 7–8). This book can be used as a textbook or a guideline for a Champion or Master Black Belt course in Six Sigma training.

I would like to thank Dr. A.K.P. Mochtan and Director Yoshikuni Ohnishi of APO, who allowed me to write this book as an APO publication. I very much appreciate the assistance of Professor Moon W. Suh at North Carolina State University who examined the manuscript in detail and greatly improved the readability of the book. Great thanks should be given to Mr. Hui J. Park and Mr. Bong G. Park, two of my doctoral students, for undertaking the lengthy task of MS word processing of the manuscript. I would especially like to thank Dr. Dag Kroslid, a Swedish Six Sigma consultant, for inspiring me to write this book and for valuable discussions on certain specific topics in the book.

Finally, I want to dedicate this book to God for giving me the necessary energy, health, and inspiration to finish the manuscript.

# 1. Six Sigma Overview

---

## 1.1 What is Six Sigma?

Sigma ( $\sigma$ ) is a letter in the Greek alphabet that has become the statistical symbol and metric of process variation. The sigma scale of measure is perfectly correlated to such characteristics as defects-per-unit, parts-per-million defectives, and the probability of a failure. Six is the number of sigma measured in a process, when the variation around the target is such that only 3.4 outputs out of one million are defects under the assumption that the process average may drift over the long term by as much as 1.5 standard deviations.

Six Sigma may be defined in several ways. Tomkins (1997) defines Six Sigma to be “a program aimed at the near-elimination of defects from every product, process and transaction.” Harry (1998) defines Six Sigma to be “a strategic initiative to boost profitability, increase market share and improve customer satisfaction through statistical tools that can lead to breakthrough quantum gains in quality.”

Six Sigma was launched by Motorola in 1987. It was the result of a series of changes in the quality area starting in the late 1970s, with ambitious ten-fold improvement drives. The top-level management along with CEO Robert Galvin developed a concept called Six Sigma. After some internal pilot implementations, Galvin, in 1987, formulated the goal of “achieving Six-Sigma capability by 1992” in a memo to all Motorola employees (Bhote, 1989). The results in terms of reduction in process variation were on-track and cost savings totalled US\$13 billion and improvement in labor productivity achieved 204% increase over the period 1987–1997 (Losianowycz, 1999).

In the wake of successes at Motorola, some leading electronic companies such as IBM, DEC, and Texas Instruments launched Six Sigma initiatives in early 1990s. However, it was

not until 1995 when GE and Allied Signal launched Six Sigma as strategic initiatives that a rapid dissemination took place in non-electronic industries all over the world (Hendricks and Kelbaugh, 1998). In early 1997, the Samsung and LG Groups in Korea began to introduce Six Sigma within their companies. The results were amazingly good in those companies. For instance, Samsung SDI, which is a company under the Samsung Group, reported that the cost savings by Six Sigma projects totalled US\$150 million (Samsung SDI, 2000a). At the present time, the number of large companies applying Six Sigma in Korea is growing exponentially, with a strong vertical deployment into many small- and medium-size enterprises as well.

As a result of consulting experiences with Six Sigma in Korea, the author (Park et. al., 1999) believes that Six Sigma is a “new strategic paradigm of management innovation for company survival in this 21st century, which implies three things: statistical measurement, management strategy and quality culture.” It tells us how good our products, services and processes really are through statistical measurement of quality level. It is a new management strategy under leadership of top-level management to create quality innovation and total customer satisfaction. It is also a quality culture. It provides a means of doing things right the first time and to work smarter by using data information. It also provides an atmosphere for solving many CTQ (critical-to-quality) problems through team efforts. CTQ could be a critical process/product result characteristic to quality, or a critical reason to quality characteristic. The former is termed as CTQy, and the latter CTQx.

## **1.2 Why is Six Sigma Fascinating?**

Six Sigma has become very popular throughout the whole world. There are several reasons for this popularity. First, it is regarded as a fresh quality management strategy which can replace TQC, TQM and others. In a sense, we can view the development process of Six Sigma as shown in Figure 1.1.

Many companies, which were not quite successful in implementing previous management strategies such as TQC and TQM, are eager to introduce Six Sigma.

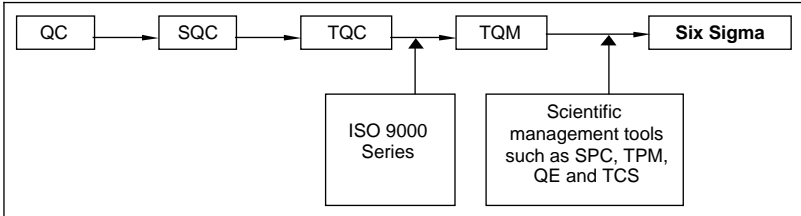

**Figure 1.1.** Development process of Six Sigma in quality management

Six Sigma is viewed as a systematic, scientific, statistical and smarter (4S) approach for management innovation which is quite suitable for use in a knowledge-based information society. The essence of Six Sigma is the integration of four elements (customer, process, manpower and strategy) to provide management innovation as shown in Figure 1.2.

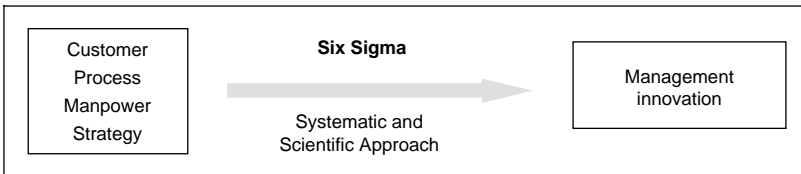

**Figure 1.2.** Essence of Six Sigma

Six Sigma provides a scientific and statistical basis for quality assessment for all processes through measurement of quality levels. The Six Sigma method allows us to draw comparisons among all processes, and tells how good a process is. Through this information, top-level management learns what path to follow to achieve process innovation and customer satisfaction.

Second, Six Sigma provides efficient manpower cultivation and utilization. It employs a “belt system” in which the levels of mastery are classified as green belt, black belt, master black belt and champion. As a person in a company obtains certain

training, he acquires a belt. Usually, a black belt is the leader of a project team and several green belts work together for the project team.

Third, there are many success stories of Six Sigma application in well known world-class companies. As mentioned earlier, Six Sigma was pioneered by Motorola and launched as a strategic initiative in 1987. Since then, and particularly from 1995, an exponentially growing number of prestigious global firms have launched a Six Sigma program. It has been noted that many globally leading companies run Six Sigma programs (see Figure 3), and it has been well known that Motorola, GE, Allied Signal, IBM, DEC, Texas Instruments, Sony, Kodak, Nokia, and Philips Electronics among others have been quite successful in Six Sigma. In Korea, the Samsung, LG, Hyundai groups and Korea Heavy Industries & Construction Company have been quite successful with Six Sigma.

Lastly, Six Sigma provides flexibility in the new millennium of 3Cs, which are:

- Change: Changing society
- Customer: Power is shifted to customer and customer demand is high
- Competition: Competition in quality and productivity

The pace of change during the last decade has been unprecedented, and the speed of change in this new millennium is perhaps faster than ever before. Most notably, the power has shifted from producer to customer. The producer-oriented industrial society is over, and the customer-oriented information society has arrived. The customer has all the rights to order, select and buy goods and services. Especially, in e-business, the customer has all-mighty power. Competition in quality and productivity has been ever-increasing. Second-rate quality goods cannot survive anymore in the market. Six Sigma with its 4S (systematic, scientific, statistical and smarter) approaches provides flexibility in managing a business unit.

### 1.3 Key Concepts of Management

The core objective of Six Sigma is to improve the performance of processes. By improving processes, it attempts to achieve three things: the first is to reduce costs, the second is to improve customer satisfaction, and the third is to increase revenue, thereby, increasing profits.

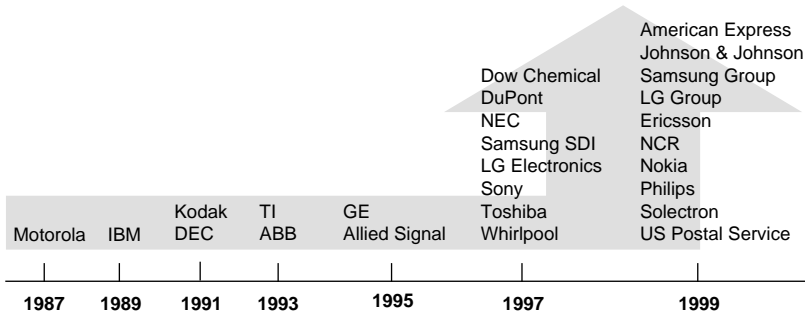

Figure 1.3. Globally well known Six Sigma companies

#### 1.3.1 Process

A general definition of a process is an activity or series of activities transforming inputs to outputs in a repetitive flow as shown in Figure 1.4. For companies, the output is predominantly a product taking the form of hardware goods with their associated services. However, an R&D activity or a non-manufacturing service activity which does not have any form of hardware goods could also be a process.

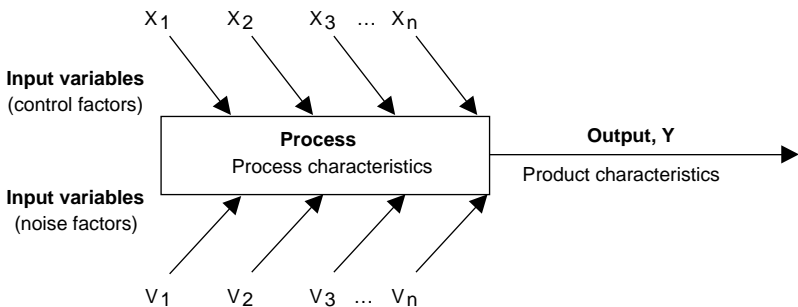

Figure 1.4. The process with inputs and outputs

Literally, the inputs can be anything from labor, materials, machines, decisions, information and measurements to temperature, humidity and weight. Inputs are either control factors which can be physically controlled, or noise factors which are considered to be uncontrollable, too costly to control, or not desirable to control.

The model of Six Sigma in terms of processes and improvement is that  $y$  is a function of  $x$  and  $v$ :

$$y = f(x_1, x_2, \dots, x_k; v_1, v_2, \dots, v_m)$$

Here,  $y$  represents the result variable (characteristics of the process or product),  $x$  represents one or more control factors, and  $v$  represents one or more noise factors. The message in the process is to find the optimal levels of  $x$  variables which give desired values of  $y$  as well as being robust to the noise factors  $v$ . The word “robust” means that the  $y$  values are not changed much as the levels of noise factors are changed.

Any given process will have one or more characteristics specified against which data can be collected. These characteristics are used for measuring process performance. To measure the process performance, we need data for the relevant characteristics. There are two types of characteristics: continuous and discrete. Continuous characteristics may take any measured value on a continuous scale, providing continuous data, whereas discrete characteristics are based on counts, providing attribute data. Examples of continuous data are thickness, time, speed and temperature. Typical attribute data are counts of pass/fail, acceptable/unacceptable, good/bad or imperfections.

### **1.3.2 Variation**

The data values for any process or product characteristic always vary. No two products or characteristics are exactly alike because any process contains many sources of variability. The differences among products may be large, or they may be immeasurably small, but they are always present. The variation, if the data values are measured, can be

visualized and statistically analyzed by means of a distribution that best fits the observations. This distribution can be characterized by:

- Location (average value)
- Spread (span of values from smallest to largest)
- Shape (the pattern of variation – whether it is symmetrical, skewed, etc.)

Variation is indeed the number one enemy of quality control. It constitutes a major cause of defectives as well as excess costs in every company. Six Sigma, through its tracking of process performance and formalized improvement methodology, focuses on pragmatic solutions for reducing variation. Variation is the key element of the process performance triangle as shown in Figure 1.5. Variation, which is the most important, relates to “how close are the measured values to the target value,” cycle time to “how fast” and yield to “how much.” Cycle time and yield are the two major elements of productivity.

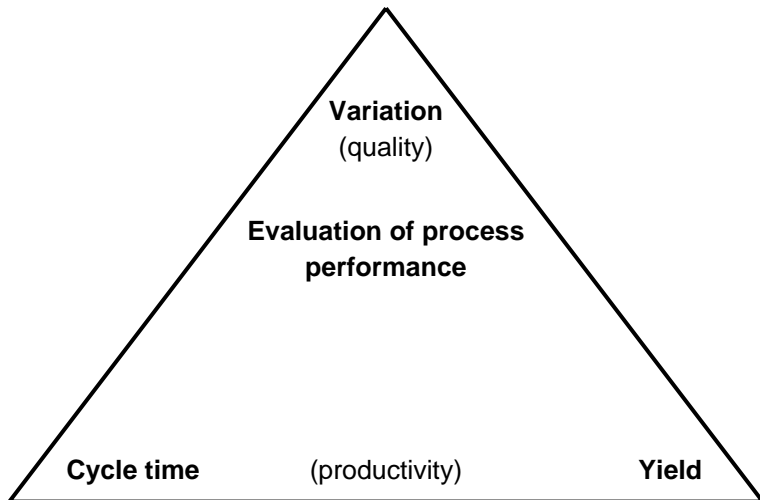

**Figure 1.5.** Process performance triangle

There are many sources of variation for process and product characteristics. It is common to classify them into two types: common causes and special causes. Common causes refer to the sources of variation within a process that have a stable and repeatable distribution over time. This is called “in a state of statistical control.” The random variation, which is inherent in the process, is not easily removable unless we change the very design of the process or product, and is a common cause found everywhere. Common causes behave like a stable system of chance causes. If only common causes of variation are present and do not change, the output of a process is predictable as shown in Figure 1.6.

If only common causes of variation are present, the output of a process forms a distribution that is stable over time and is predictable:

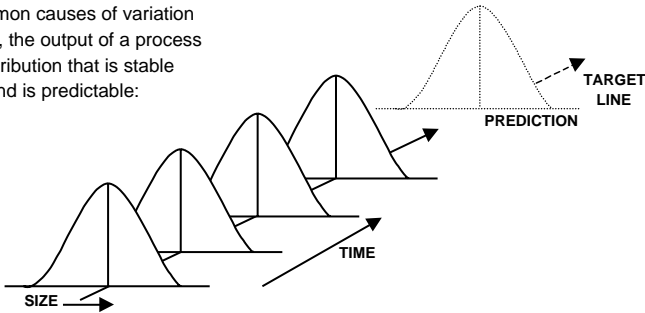

If special causes of variation are present, the process output is not stable over time:

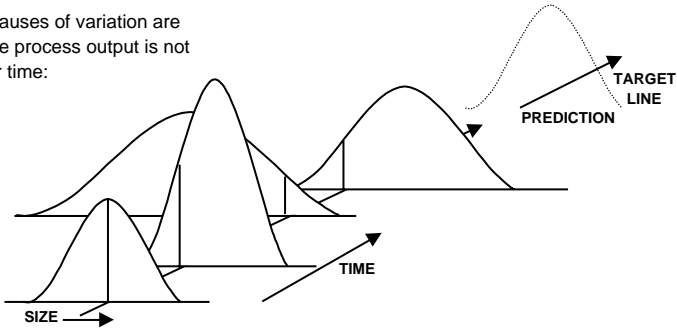

**Figure 1.6.** Variation: Common and special causes

Special causes (often called assignable causes) refer to any factors causing variation that are usually not present in the

process. That is, when they occur, they make a change in the process distribution. Unless all the special causes of variation are identified and acted upon, they will continue to affect the process output in unpredictable ways. If special causes are present, the process output is not stable over time.

### *1.3.3 Cycle time, yield and productivity*

Every process has a cycle time and yield. The cycle time of a process is the average time required for a single unit to complete the transformation of all input factors into an output. The yield of a process is the amount of output related to input time and pieces. A more efficient transformation of input factors into products will inevitably give a better yield.

Productivity is used in many different aspects (see Toru Sase (2001)). National productivity can be expressed as GDP/population where GDP means the gross domestic product. Company productivity is generally defined as the “function of the output performance of the individual firm compared with its input.” Productivity for industrial activity has been defined in many ways, but the following definition proposed by the European Productivity Agency (EPA) in 1958 is perhaps the best.

- Productivity is the degree of effective utilization of each element of production.
- Productivity is, above all, an attitude of mind. It is based on the conviction that one can do things better today than yesterday, and better tomorrow than today. It requires never-ending efforts to adapt economic activities to changing conditions, and the application of new theories and methods. It is a firm belief in the progress of human beings.

The first paragraph refers to the utilization of production elements, while the second paragraph explains the social effects of productivity. Although the product is the main output of an enterprise, other tasks such as R&D activities, sale of products and other service activities are also closely linked

to productivity. In economic terms, productivity refers to the extent to which a firm is able to optimize its management resources in order to achieve its goals. However, in this book we adopt the definition of productivity as in the first paragraph, which is narrow in scope. Thus, if cycle time and yield in the process performance triangle of Figure 1.5 are improved, productivity can be improved accordingly.

#### ***1.3.4 Customer satisfaction***

Customer satisfaction is one of the watchwords for company survival in this new 21st century. Customer satisfaction can be achieved when all the customer requirements are met. Six Sigma emphasizes that the customer requirements must be fulfilled by measuring and improving processes and products, and CTQ (critical-to-quality) characteristics are measured on a consistent basis to produce few defects in the eyes of the customer.

The identification of customer requirements is ingrained in Six Sigma and extended into the activity of translating requirements into important process and product characteristics. As customers rarely express their views on process and product characteristics directly, a method called QFD (quality function deployment) is applied for a systematic translation (see Chapter 4). Using QFD, it is possible to prioritize the importance of each characteristic based on input from the customer.

Having identified the CTQ requirements, the customer is usually asked to specify what the desired value for the characteristic is, i.e., target value, and what a defect for the characteristic is, i.e., specification limits. This vital information is utilized in Six Sigma as a basis for measuring the performance of processes.

Six Sigma improvement projects are supposed to focus on improvement of customer satisfaction which eventually gives increased market share and revenue growth. As a result of revenue growth and cost reduction, the profit increases and the commitment to the methodology and further improvement projects are generated throughout the company. This kind of

loop is called “Six Sigma loop of improvement projects,” and was suggested by Magnusson, et. al. (2001). This loop is shown in Figure 1.7.

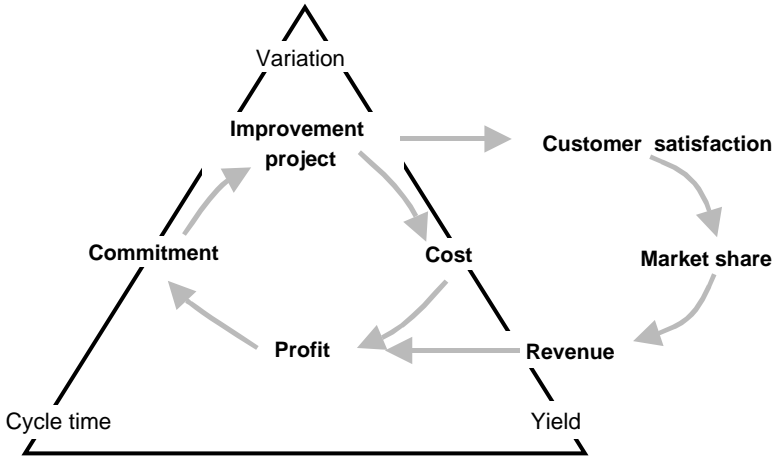

**Figure 1.7.** Six Sigma loop of improvement projects

#### 1.4 Measurement of Process Performance

Among the dimensions of the process performance triangle in Figure 1.5, variation is the preferred measurement for process performance in Six Sigma. Cycle time and yield could have been used, but they can be covered through variation. For example, if a cycle time has been specified for a process, the variation of the cycle time around its target value will indicate the performance of the process in terms of this characteristic. The same applies to yield.

The distribution of a characteristic in Six Sigma is usually assumed to be Normal (or Gaussian) for continuous variables, and Poissonian for discrete variables. The two parameters that determine a Normal distribution are population mean,  $\mu$ , and population standard deviation,  $\sigma$ . The mean indicates the location of the distribution on a continuous scale, whereas the standard deviation indicates the dispersion.

### 1.4.1 Standard deviation and Normal distribution

The population parameters,  $\mu$  (population mean),  $\sigma$  (population standard deviation) and  $\sigma^2$  (population variance), are usually unknown, and they are estimated by the sample statistics as follows.

$\bar{y}$  = sample mean = estimate of  $\mu$

$s$  = sample standard deviation = estimate of  $\sigma$

$V$  = sample variance = estimate of  $\sigma^2$

If we have a sample of size  $n$  and the characteristics are  $y_1, y_2, \dots, y_n$ , then  $\mu, \sigma$  and  $\sigma^2$  are estimated by, respectively

$$\begin{aligned} \bar{y} &= \frac{y_1 + y_2 + \dots + y_n}{n} \\ s &= \sqrt{V} \\ V &= \frac{\sum_{i=1}^n (y_i - \bar{y})^2}{n-1} \end{aligned} \tag{1.1}$$

However, if we use an  $\bar{x} - R$  control chart, in which there are  $k$  subgroups of size  $n$ ,  $\sigma$  can be estimated by

$$s = \frac{\bar{R}}{d_2} \tag{1.2}$$

where  $\bar{R} = R_i/n$ , and  $R_i$  is the range for each subgroup and  $d_2$  is a constant value that depends on the sample size  $n$ . The values of  $d_2$  can be found in Appendix A-4.

Many continuous random variables, such as the dimension of a part and the time to fill the order for a customer, follow a normal distribution.

Figure 1.8 illustrates the characteristic bell shape of a normal distribution where  $X$  is the normal random variable,  $\mu$  is the population mean and  $\sigma$  is the population standard deviation. The probability density function (PDF),  $f(x)$ , of a normal distribution is

$$f(x) = \frac{1}{\sqrt{2\pi}\sigma} e^{-\frac{1}{2}\left[\frac{x-\mu}{\sigma}\right]^2} \quad (1.3)$$

where we usually denote  $X \sim N(\mu, \sigma^2)$

When  $X \sim N(\mu, \sigma^2)$ , it can be converted into standard normal variable  $Z \sim N(0,1)$  using the relationship of variable transformation,

$$Z = \frac{X - \mu}{\sigma} \quad (1.4)$$

whose probability density function is

$$f(z) = \frac{1}{\sqrt{2\pi}} e^{-\frac{1}{2}z^2} \quad (1.5)$$

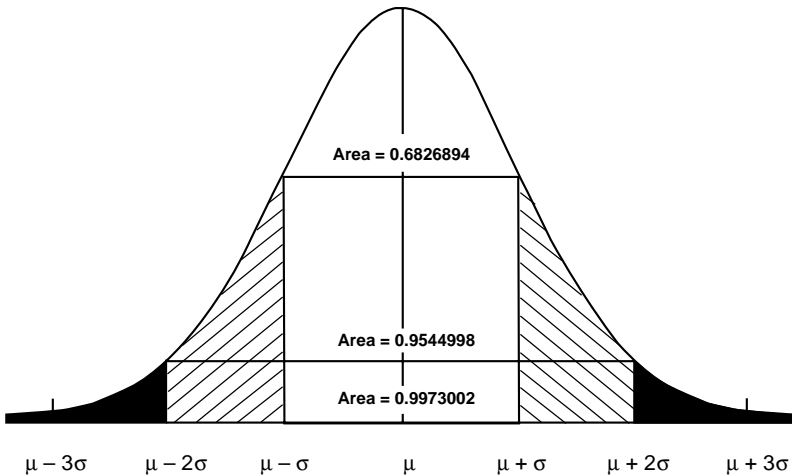

**Figure 1.8.** Normal distribution

### **1.4.2 Defect rate, ppm and DPMO**

The defect rate, denoted by  $p$ , is the ratio of the number of defective items which are out of specification to the total number of items processed (or inspected). Defect rate or fraction of defective items has been used in industry for a long time. The number of defective items out of one million inspected items is called the ppm (parts-per-million) defect rate. Sometimes a ppm defect rate cannot be properly used, in particular, in the cases of service work. In this case, a DPMO (defects per million opportunities) is often used. DPMO is the number of defective opportunities which do not meet the required specification out of one million possible opportunities.

### **1.4.3 Sigma quality level**

Specification limits are the tolerances or performance ranges that customers demand of the products or processes they are purchasing. Figure 1.8 illustrates specification limits as the two major vertical lines in the figure. In the figure, LSL means the lower specification limit, USL means the upper specification limit and T means the target value. The sigma quality level (in short, sigma level) is the distance from the process mean ( $\mu$ ) to the closer specification limit.

In practice, we desire that the process mean to be kept at the target value. However, the process mean during one time period is usually different from that of another time period for various reasons. This means that the process mean constantly shifts around the target value. To address typical maximum shifts of the process mean, Motorola added the shift value  $\pm 1.5\sigma$  to the process mean. This shift of the mean is used when computing a process sigma level as shown in Figure 1.10. From this figure, we note that a  $6\sigma$  quality level corresponds to a 3.4ppm rate. Table 1.1 illustrates how sigma quality levels would equate to other defect rates and organizational performances. Table 1.2 shows the details of this relationship when the process mean is  $\pm 1.5\sigma$  shifted.

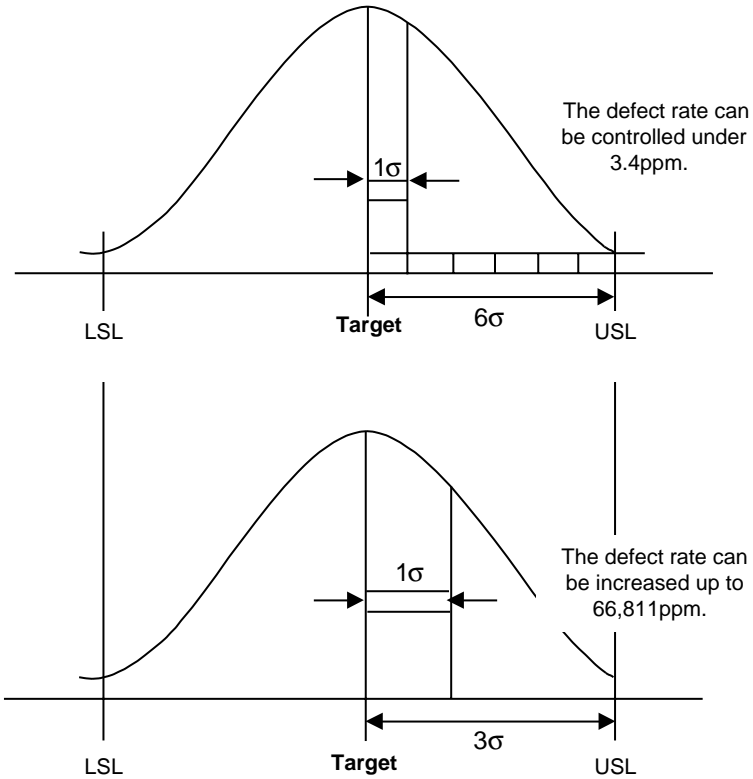

Figure 1.9. Sigma quality levels of 6σ and 3σ

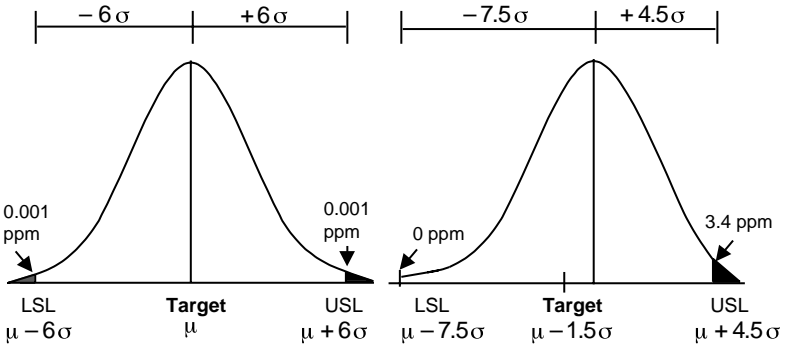

Figure 1.10. Effects of a 1.5σ shift of process mean when 6σ quality level is achieved

**Table 1.1.** ppm changes when sigma quality level changes

Sigma quality level	Process mean, fixed		Process mean, with 1.5σ shift	
	Non-defect rate (%)	Defect rate (ppm)	Non-defect rate (%)	Defect rate (ppm)
σ	68.26894	317,311	30.2328	697,672
2σ	95.44998	45,500	69.1230	308,770
3σ	99.73002	2,700	93.3189	66,811
4σ	99.99366	63.4	99.3790	6,210
5σ	99.999943	0.57	99.97674	233
6σ	99.9999998	0.002	99.99966	3.4

**1.4.4 DPU, DPO and Poisson distribution**

Let us suppose for the sake of discussion that a certain product design may be represented by the area of a rectangle. Let us also postulate that each rectangle contains eight equal areas of opportunity for non-conformance (defect) to standard. Figure 1.11 illustrates three particular products. The first one has one defect and the third one has two defects.

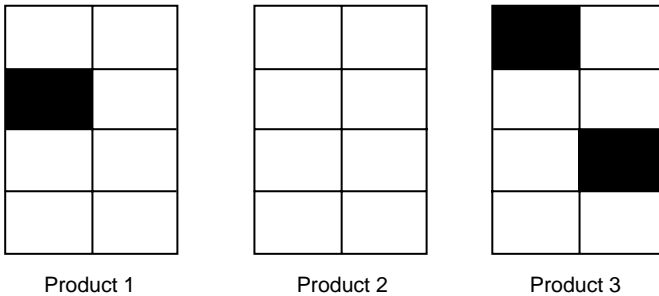

**Figure 1.11.** Products consisting of eight equal areas of opportunity for non-conformance

The defects per unit (*DPU*) is defined as

$$DPU = \frac{\text{Total defects observed of number}}{\text{Total number of unit products produced}} \quad (1.6)$$

In Figure 1.11, *DPU* is  $3/3 = 1.00$ , which means that, on average, each unit product will contain one such defect. Of course, this assumes that the defects are randomly distributed.

We must also recognize, however, that within each unit of product there are eight equal areas of opportunity for non-conformance to standard.

**Table 1.2.** Detailed conversion between ppm (or *DPMO*) and sigma quality level when the process mean is  $\pm 1.5\sigma$  shifted

Sigma Level	0.00	0.01	0.02	0.03	0.04	0.05	0.06	0.07	0.08	0.09
2.0	308770.2	305249.8	301747.6	298263.7	294798.6	291352.3	287925.1	284517.3	281129.1	277760.7
2.1	274412.2	271084.0	267776.2	264489.0	261222.6	257977.2	254753.0	251550.2	248368.8	245209.2
2.2	242071.5	238955.7	235862.1	232790.8	229742.0	226715.8	223712.2	220731.6	217773.9	214839.2
2.3	211927.7	209039.6	206174.8	203333.5	200515.7	197721.6	194951.2	192204.6	189481.9	186783.0
2.4	184108.2	181457.4	178830.7	176228.0	173649.5	171095.2	168565.1	166059.2	163577.5	161120.1
2.5	158686.9	156278.0	153893.3	151532.9	149196.7	146884.7	144596.8	142333.2	140093.6	137878.1
2.6	135686.7	133519.3	131375.8	129256.3	127160.5	125088.6	123040.3	121015.7	119014.7	117037.0
2.7	115083.0	113152.2	111244.7	109360.2	107498.9	105660.5	103844.9	102052.1	100281.9	98534.3
2.8	96809.0	95106.1	93425.3	91766.6	90129.8	88514.8	86921.5	85349.7	83799.3	82270.1
2.9	80762.1	79275.0	77808.8	76363.2	74938.2	73533.6	72149.1	70784.8	69440.4	68115.7
3.0	66810.6	65525.0	64258.6	63011.3	61783.0	60573.4	59382.5	58210.0	57055.8	55919.6
3.1	54801.4	53700.9	52618.1	51552.6	50504.3	49473.1	48458.8	47461.2	46480.1	45515.3
3.2	44566.8	43634.2	42717.4	41816.3	40930.6	40060.2	39204.9	38364.5	37538.9	36727.8
3.3	35931.1	35148.6	34380.2	33625.7	32884.8	32157.4	31443.3	30742.5	30054.6	29379.5
3.4	28717.0	28067.1	27429.4	26803.8	26190.2	25588.4	24988.2	24419.5	23852.1	23295.8
3.5	22705.4	22215.9	21692.0	21178.5	20675.4	20182.4	19699.5	19226.4	18763.0	18309.1
3.6	17864.6	17429.3	17003.2	16586.0	16177.5	15777.7	15386.5	15003.5	14628.8	14262.2
3.7	13903.5	13552.7	13209.5	12873.8	12545.5	12224.5	11910.7	11603.9	11303.9	11010.7
3.8	10724.2	10444.1	10170.5	9903.1	9641.9	9386.7	9137.5	8894.1	8656.4	8424.2
3.9	8197.6	7976.3	7760.3	7549.4	7343.7	7142.8	6946.9	6755.7	6569.1	6387.2
4.0	6209.7	6036.6	5867.8	5703.1	5542.6	5386.2	5233.6	5084.9	4940.0	4798.8
4.1	4661.2	4527.1	4396.5	4269.3	4145.3	4024.6	3907.0	3792.6	3681.1	3572.6
4.2	3467.0	3364.2	3264.1	3166.7	3072.0	2979.8	2890.1	2802.8	2717.9	2635.4
4.3	2555.1	2477.1	2401.2	2327.4	2255.7	2186.0	2118.2	2052.4	1988.4	1926.2
4.4	1865.8	1807.1	1750.2	1694.8	1641.1	1588.9	1538.2	1489.0	1441.2	1394.9
4.5	1349.9	1306.2	1263.9	1222.8	1182.9	1144.2	1106.7	1070.3	1035.0	1000.8
4.6	967.6	935.4	904.3	874.0	844.7	816.4	788.8	762.2	736.4	711.4
4.7	687.1	663.7	641.0	619.0	597.6	577.0	557.1	537.7	519.0	500.9
4.8	483.4	466.5	450.1	434.2	418.9	404.1	389.7	375.8	362.4	349.5
4.9	336.9	324.8	313.1	301.8	290.9	280.3	270.1	260.2	250.7	241.5
5.0	232.6	224.1	215.8	207.8	200.1	192.6	185.4	178.5	171.8	165.3
5.1	159.1	153.1	147.3	141.7	136.3	131.1	126.1	121.3	116.6	112.1
5.2	107.8	103.6	99.6	95.7	92.0	88.4	85.0	81.6	78.4	75.3
5.3	72.3	69.5	66.7	64.1	61.5	59.1	56.7	54.4	52.2	50.1
5.4	48.1	46.1	44.3	42.5	40.7	39.1	37.5	35.9	34.5	33.0
5.5	31.7	30.4	29.1	27.9	26.7	25.6	24.5	23.5	22.5	21.6
5.6	20.7	19.8	18.9	18.1	17.4	16.6	15.9	15.2	14.6	13.9
5.7	13.3	12.8	12.2	11.7	11.2	10.7	10.2	9.8	9.3	8.9
5.8	8.5	8.2	7.8	7.5	7.1	6.8	6.5	6.2	5.9	5.7
5.9	5.4	5.2	4.9	4.7	4.5	4.3	4.1	3.9	3.7	3.6
6.0	3.4	3.2	3.1	2.9	2.8	2.7	2.6	2.4	2.3	2.2
6.1	2.1	2.0	1.9	1.8	1.7	1.7	1.6	1.5	1.4	1.4
6.2	1.3	1.2	1.2	1.1	1.1	1.0	1.0	0.9	0.9	0.8
6.3	0.8	0.8	0.7	0.7	0.6	0.6	0.6	0.6	0.5	0.5
6.4	0.5	0.5	0.4	0.4	0.4	0.4	0.4	0.3	0.3	0.3
6.5	0.3	0.3	0.3	0.2	0.2	0.2	0.2	0.2	0.2	0.2
6.6	0.2	0.2	0.2	0.1	0.1	0.1	0.1	0.1	0.1	0.1
6.7	0.1	0.1	0.1	0.1	0.1	0.1	0.1	0.1	0.1	0.1
6.8	0.1	0.1	0.1	0.0	0.0	0.0	0.0	0.0	0.0	0.0

Because of this, we may calculate the defects per unit opportunity (DPO)

$$DPO = \frac{DPU}{m} \quad (1.7)$$

where  $m$  is the number of independent opportunities for non-conformance per unit. In the instance of our illustrated example, since  $m = 8$ ,

$$DPO = \frac{1.00}{8} = 0.125$$

or 12.5 percent. Inversely, we may argue that there is an 84 percent chance of not encountering a defect with respect to any given unit area of opportunity. By the same token, the defects-per-million opportunities (DPMO) becomes

$$DPMO = \frac{DPU}{m} \times 1,000,000 = \frac{1.00}{8} \times 1,000,000 = 125,000 .$$

It is interesting to note that the probability of zero defects, for any given unit of product, would be  $(0.875)^8 = 0.3436$ , or 34.36 percent. Then, we may now ask the question, "What is the probability that any given unit of product will contain one, two or three more defects?" This question can be answered by applying a Poisson distribution.

The probability of observing exactly  $X$  defects for any given unit of product is given by the Poisson probability density function:

$$P(X = x) = p(x) = \frac{e^{-\lambda} \lambda^x}{x!}, \quad x = 0,1,2,3,\dots \quad (1.8)$$

where  $e$  is a constant equal to 2.71828 and  $\lambda$  is the average number of defects for a unit of product. To better relate the Poisson relation to our example, we may rewrite the above equation as

$$p(x) = \frac{e^{-DPU} (DPU)^x}{x!}, \quad (1.9)$$

which can be effectively used when  $DPO = DPU / m$  is less than 10 percent and  $m$  is relatively large. Therefore, the probability that any given unit of product will contain only one defect is

$$p(x) = \frac{e^{-1.00}(1.00)^1}{1!} = 0.3679.$$

For the special case of  $x = 0$ , which is the case of zero defect for a given unit of product, the probability becomes

$$p(x) = e^{-1.00} = 0.3679$$

and this is somewhat different from the probability 0.3436 that was previously obtained. This is because  $DPO$  is greater than 10 percent and  $m$  is rather small.

#### 1.4.5 Binomial trials and their approximations

A binomial distribution is useful when there are only two results (e.g., defect or non-defect, conformance or non-conformance, pass or fail) which is often called a binomial trial. The probability of exactly  $x$  defects in  $n$  inspected trials whether they are defects or not, with probability of defect equal to  $p$  is

$$p(X = x) = p(x) = \binom{n}{x} p^x q^{n-x} = \frac{n!}{x!(n-x)!} p^x q^{n-x}, \quad x = 0, 1, 2, \dots, n, \quad (1.10)$$

where  $q = 1 - p$  is the probability of non-defect. In practice, the computation of the probability  $P(a \leq X \leq b)$  is usually difficult if  $n$  is large. However, if  $np \geq 5$  and  $nq \geq 5$ , the probability can be easily approximated by using  $E(X) = \mu = np$  and  $V(X) = \sigma^2 = npq$ , where  $E$  and  $V$  represent expected value and variance, respectively.

if  $p \leq 0.1$  and  $n \geq 50$ , the probability in (1.10) can be well approximated by a Poisson distribution as follows.

$$p(x) = \frac{e^{-np} (np)^x}{x!}. \quad (1.11)$$

Hence, for the case of Figure 1.11, the probability of zero defects for a given unit of product can be obtained by either (1.10) or (1.11).

Since  $n = 8$ ,  $p = DPO = 0.125$ ,  $q = 0.875$ ,  $np = 8 \times 0.125 = 1$  and  $x = 0$ ,

$$\text{from (1.10), } p(x=0) = \frac{8!}{0!8!} (0.125)^0 (0.875)^8 = 0.3436,$$

$$\text{from (1.11), } p(x=0) = \frac{e^{-1}(1)^0}{0!} = 0.3679.$$

Note that since  $p = 0.125$  is not smaller than 0.1 and  $n = 8$  is not large enough, the Poisson approximation from (1.11) is not good enough.

#### 1.4.6 Process capability index

There are two metrics that are used to measure the process capability. One is potential process capability index ( $Cp$ ), and another is process capability index ( $Cpk$ )

##### (1) Potential process capability index ( $Cp$ )

$Cp$  index is defined as the ratio of specification width over the process spread as follows.

$$Cp = \frac{\text{specification width}}{\text{process spread}} = \frac{USL - LSL}{6\sigma} \quad (1.12)$$

The specification width is predefined and fixed. The process spread is the sole influence on the  $Cp$  index. The population standard deviation,  $\sigma$ , is usually estimated by the equations (1.1) or (1.2). When the spread is wide (more variation), the  $Cp$  value is small, indicating a low process capability. When the spread is narrow (less variation), the  $Cp$  value becomes larger, indicating better process capability.



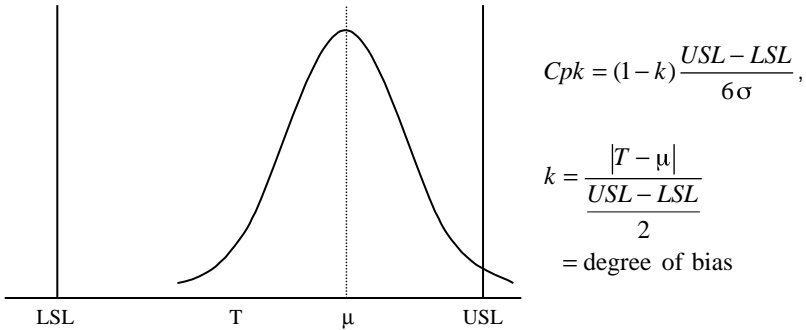

**Figure 1.13.** Process capability index ( $Cpk$ )

We have dealt with the case when there are two specification limits,  $USL$  and  $LSL$ . However, when there is a one-sided specification limit, or when the target is not specified,  $Cpk$  may be more conveniently calculated as:

$$Cpk = \frac{|\text{process mean}(\mu) - \text{closer specification limit from } \mu|}{3\sigma}. \quad (1.15)$$

We often use upper capability index ( $CPU$ ) and lower capability index ( $CPL$ ).  $CPU$  is the upper tolerance spread divided by the actual upper process spread.  $CPL$  is defined as the lower tolerance spread divided by the actual lower process spread.

$$CPU = \frac{USL - \mu}{3\sigma}, \quad CPL = \frac{\mu - LSL}{3\sigma} \quad (1.16)$$

$Cpk$  in (1.15) may be defined as the minimum of  $CPU$  or  $CPL$ . It relates the scaled distance between the process mean and the closest specification limit to half the total process spread.

$$Cpk = \min(CPU, CPL) \quad (1.17)$$

### (3) Relationship between $Cp$ , $Cpk$ and Sigma level

If the process mean is centered, that is  $\mu = T$ , and  $USL - LSL = 6\sigma$ , then from (1.12), it is easy to know that  $Cp = 1$ , and the distance from  $\mu$  to the specification limit is  $3\sigma$ . In this

case, the sigma (quality) level becomes  $3\sigma$ , and the relationship between  $Cp$  and the sigma level is

$$\text{Sigma level} = 3 \times Cp \quad (1.18)$$

However, in the long run the process mean could shift at most by  $1.5\sigma$  to the right or left hand side, and the process mean cannot be centered, that is, it can be biased.

In the long-term, if the process mean is  $1.5\sigma$  biased and  $Cpk = 1$  then the sigma level becomes  $3\sigma + 1.5\sigma = 4.5\sigma$ . Figure 1.14 shows a  $6\sigma$  process with typical  $1.5\sigma$  shift. In this case,  $Cpk = 1.5$  and the sigma level is  $6\sigma$ . In general, the relationship between  $Cpk$  and the sigma level is

$$\begin{aligned} \text{Sigma level} &= 3 \times Cpk + 1.5 \\ &= 3 \times (Cpk + 0.5) \end{aligned} \quad (1.19)$$

Hence, in the long-term the relationship between  $Cp$  and  $Cpk$  is from (1.18) and (1.19),

$$Cpk = Cp - 0.5. \quad (1.20)$$

Table 1.3 shows the relationship between process capability index and sigma level.

**Table 1.3** Relationship between  $Cp$ ,  $Cpk$  and Sigma level

$Cp$	$Cpk$ (5.1 $\sigma$ shift is allowed)	Quality level
0.50	0.00	1.5 $\sigma$
0.67	0.17	2.0 $\sigma$
0.83	0.33	2.5 $\sigma$
1.00	0.50	3.0 $\sigma$
1.17	0.67	3.5 $\sigma$
1.33	0.83	4.0 $\sigma$
1.50	1.00	4.5 $\sigma$
1.67	1.17	5.0 $\sigma$
1.83	1.33	5.5 $\sigma$
2.00	1.50	6.0 $\sigma$

### 1.4.7 Rolled throughput yield (RTY)

Rolled throughput yield (RTY) is the final cumulative yield when there are several processes connected in series. RTY is the amount of non-defective products produced in the final process compared with the total input in the first process.

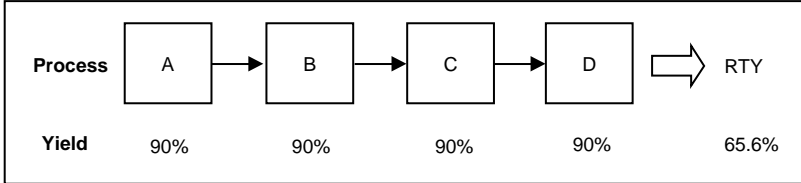

**Figure 1.14** RTY and yield of each process

For example, as shown in Figure 1.14, there are four processes (A, B, C and D) connected in consecutive series, and each process has a 90% yield.

Then RTY of these processes is  $RTY = 0.9 \times 0.9 \times 0.9 \times 0.9 = 0.656$ .

If there are  $k$  processes in series, and the  $i$ th process has its own yield  $y_i$ , then RTY of these  $k$  processes is

$$RTY = y_1 \times y_2 \times \dots \times y_k \tag{1.21}$$

### 1.4.8 Unified quality level for multi-characteristics

In reality, there is more than one characteristic and we are faced with having to compute a unified quality level for multi-characteristics. As shown in Table 1.4, suppose there are three characteristics and associated defects. Table 1.4 illustrates how to compute  $DPU$ ,  $DPO$ ,  $DPMO$  and sigma level. The way to convert from  $DPMO$  (or ppm) to sigma level can be found in Table 1.2.

**Table 1.4.** Computation of unified quality level

Characteristic number	Number of defects	Number of units	Opportunities per unit	Total opportunities	DPU	DPO	DPMO	Sigma level
1	78	600	10	6,000	0.130	0.0130	13,000	3.59
2	29	241	100	24,100	0.120	0.0012	1,200	4.55
3	64	180	3	540	0.356	0.1187	118,700	2.59
<b>Total</b>	171			30,640		0.00558	5,580	3.09

### 1.4.9 Sigma level for discrete data

When a given set of data is continuous, we can easily obtain the mean and standard deviation. Also from the given specification limits, we can compute the sigma level. However, if the given set of data is discrete, such as number of defects, we should convert the data to yield and obtain the sigma level using the standard normal distribution in Appendix table A-1. Suppose the non-defect rate for a given set of discrete data is  $y$ . Then the sigma level  $Z$  can be obtained from the relationship  $\Phi(z) = y$ , where  $\Phi$  is the standard cumulative normal distribution

$$\Phi(z) = \int_{-\infty}^z \frac{1}{\sqrt{2\pi}} e^{-\frac{w^2}{2}} dw \quad (1.22)$$

$$= y$$

For example, if  $y = 0.0228$ , then  $z = 2.0$  from Appendix A-1. If this  $y$  value is obtained in the long-term, then a short-term sigma level should be

$$Z_s = Z_l + 1.5, \quad (1.23)$$

considering the  $1.5\sigma$  mean shift. Here,  $Z_s$  and  $Z_l$  mean a short-term and long-term sigma level, respectively.

The methods of computing sigma levels are explained below for each particular case.

(1) Case of DPU

Suppose that the pinhole defects in a coating process have been found in five units out of 500 units inspected from a long-term investigation. Since the number of defects follows a Poisson distribution, and  $DPU = 5/500 = 0.01$ , the probability of zero defect is from (1.9),

$$y = e^{-DPU} = e^{-0.01} = 0.99005,$$

and the corresponding  $Z$  value is  $Z = 2.33$ . Since the set of data has been obtained for a long-term, the short-term sigma level is  $Z_s = 2.33 + 1.5 = 3.83$

(2) Case of defect rate

If  $r$  products, whose measured quality characteristics are outside the specifications, have been classified to be defective out of  $n$  products investigated, the defect rate is  $p = r/n$ , and the yield is  $y = 1 - p$ . Then we can find the sigma level  $Z$  from the relationship (1.22). For example, suppose two products out of 100 products have a quality characteristic which is outside of specification limits. Then the defect rate is 2 percent, and the yield is 98 percent. Then the sigma level is approximately  $Z = 2.05$  from (1.22).

If this result is based on a long-term investigation, then the short-term sigma level is  $Z_s = 2.05 + 1.5 = 3.55$ .

Table 1.5 shows the relationship between short-term sigma level,  $Z$  value, defect rate and yield.

**Table 1.5.** Relationship between sigma level, defect rate and yield

Sigma level (considering 1.5 $\sigma$ shift)	Z value from standard normal distribution	Defect rate (ppm)	Yield (%)
2 $\sigma$	0.5	308,770	69.1230
3 $\sigma$	1.5	66,811	93.3189
4 $\sigma$	2.5	6,210	99.3790
5 $\sigma$	3.5	233	99.9767
6 $\sigma$	4.5	3.4	99.99966

### **(3) Case of RTY**

Suppose there are three processes in consecutive series, and the yield of each process is 0.98, 0.95, and 0.96, respectively. Then  $RTY = 0.98 \times 0.95 \times 0.96 = 0.89376$ , and the sigma levels of the processes are 3.55, 3.14, and 3.25, respectively. However, the sigma level of the entire process turns out to be 2.75, which is much lower than that of each process.

## **1.5 Relationship between Quality and Productivity**

Why should an organization try to improve quality and productivity? If a firm wants to increase its profits, it should increase productivity as well as quality. The simple idea that increasing productivity will increase profits may not always be right. The following example illustrates the folly of such an idea.

Suppose Company A has produced 100 widgets per hour, of which 10 percent are defective for the past 3 years. The Board of Directors demands that top-level management increase productivity by 10 percent. The directive goes out to the employees, who are told that instead of producing 100 widgets per hour, the company must produce 110. The responsibility for producing more widgets falls on the employees, creating stress, frustration, and fear. They try to meet the new demand but must cut corners to do so. The pressure to raise productivity creates a defect rate of 20 percent and increases good production to only 88 units, fewer than the original 90 as shown in Table 1.6 (a). This indicates that productivity increase is only meaningful when the level of quality does not deteriorate.

Very often, quality improvement results in a productivity improvement. Let's take an example. Company B produces 100 widgets per hour with 10% defectives. The top-level management is continually trying to improve quality, thereby increasing the productivity. Top-level management realizes that the company is making 10% defective units, which translates into 10% of the total cost being spent in making bad

units. If managers can improve the process, they can transfer resources from the production of defective units to the manufacture of additional good products. The management can improve the process by making some changes at no additional cost, so only 5% of the output are defective. This results in an increase in productivity, as shown in Table 1.6 (b). Management’s ability to improve the process results in a reduction of defective units, yielding an increase in good units, quality, and eventually productivity.

**Table 1.6.** Productivity vs. quality approach to improvement

	(a) Company A	
	Before demand for 10% productivity increase	After demand for 10% productivity increase
<b>Widgets produced</b>	(defect rate = 10%) 100 units	(defect rate = 20%) 110 units
<b>Widgets defective</b>	10 units	22 units
<b>Good widgets</b>	90 units	88 units

	(b) Company B	
	Before improvement	After improvement
<b>Units produced</b>	(defect rate = 10%) 100 units	(defect rate = 5%) 100 units
<b>Units defective</b>	10 units	5 units
<b>Good units</b>	90 units	95 units

Deming (1986), looking at the relationship between quality and productivity, stresses improving quality in order to increase productivity. To become an excellent company, the management should find ways to improve quality as well as productivity simultaneously. Then, several benefits result:

- Productivity rises.
- Quality improves.
- Cost per good unit decreases.

- Price can be cut.
- Workers' morale improves because they are not seen as the problem.

Stressing productivity only may mean sacrificing quality and possibly decreasing output. Also stressing quality only may mean sacrificing productivity and possibly leading to high cost. Therefore, quality and productivity should go together, and neither one should be sacrificed. Such simultaneous efforts can produce all the desired results: better quality, less rework, greater productivity, lower unit cost, price elasticity, improved customer satisfaction, larger profits and more jobs. After all, customers get high quality at a low price, vendors get predictable long-term sources of business, and investors get profits, a “win-win” situation for everyone.

## 2. Six Sigma Framework

---

### 2.1 Five Elements of the Six Sigma Framework

Management strategies, such as TQC, TQM, and Six Sigma, are distinguished from each other by their underlying rationale and framework. As far as the corporate framework of Six Sigma is concerned, it embodies the five elements of top-level management commitment, training schemes, project team activities, measurement system and stakeholder involvement as shown in Figure 2.1.

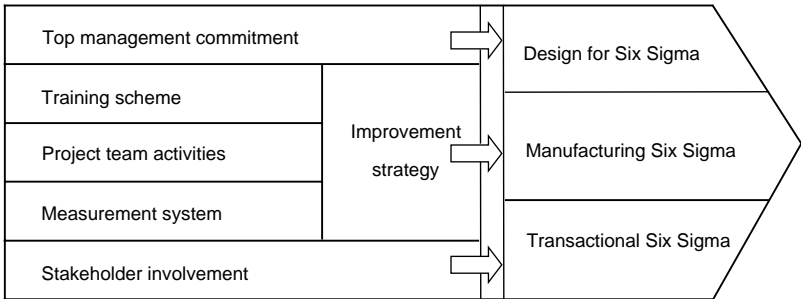

**Figure 2.1.** The corporate framework of Six Sigma

Stakeholders include employees, owners, suppliers and customers. At the core of the framework is a formalized improvement strategy with the following five steps: define, measure, analyse, improve and control (DMAIC) which will be explained in detail in Section 2.3. The improvement strategy is based on training schemes, project team activities and measurement system. Top-level management commitment and stakeholder involvement are all inclusive in the framework. Without these two, the improvement strategy functions poorly. All five elements support the improvement strategy and improvement project teams.

Most big companies operate in three parts: R&D, manufacturing, and non-manufacturing service. Six Sigma can be

introduced into each of these three parts separately. In fact, the color of Six Sigma could be different for each part. Six Sigma in the R&D part is often called “Design for Six Sigma (DFSS),” “Manufacturing Six Sigma” in manufacturing, and “Transactional Six Sigma (TSS)” in the non-manufacturing service sector. All five elements in Figure 2.1 are necessary for each of the three different Six Sigma functions. However, the improvement methodology, DMAIC, could be modified in DFSS and TSS. These points will be explained in detail in Sections 2.6 and 2.7.

## **2.2 Top-level Management Commitment and Stakeholder Involvement**

### ***(1) Top-level management commitment***

Launching Six Sigma in a company is a strategic management decision that needs to be initiated by top-level management. All the elements of the framework, as well as the formalized improvement strategy, need top-level management commitment for successful execution. Especially, without a strong commitment on the part of top-level management, the training program and project team activities are seldom successful. Although not directly active in the day-to-day improvement projects, the role of top-level management as leaders, project sponsors and advocates is crucial. Pragmatic management is required, not just lip service, as the top-level management commits itself and the company to drive the initiative for several years and into every corner of the company.

There are numerous pragmatic ways for the CEO (chief executive officer) to manifest his commitment. First, in setting the vision and long-term or short-term goal for Six Sigma, the CEO should play a direct role. Second, the CEO should allocate appropriate resources in order to implement such Six Sigma programs as training schemes, project team activities and measurement system. Third, the CEO should regularly check the progress of the Six Sigma program to determine

whether there are any problems which might hinder its success. He should listen to Six Sigma reports and make comments on the progress of Six Sigma. Fourth, he should hold a Six Sigma presentation seminar regularly, say twice a year, in which the results of the project team are presented and good results rewarded financially. Finally, he should hold a Champion Day regularly, say once in every other month, in which Champions (upper managers) are educated by specially invited speakers and he should discuss the progress of Six Sigma with the Champions.

The stories of Robert W. Galvin of Motorola, Allen Yurko of Invensys, and John F. Welch of GE display many similarities. They all gave Six Sigma top priority. For example, Galvin, the former CEO and chairman, now head of the executive committee of Motorola, always asked to hear the Six Sigma reports from different divisions first in every operations meeting. Allen Yurko of Invensys, a global electronics and engineering company with headquarters in London, chose to state his famous “5-1-15-20 goals of Six Sigma” in terms of cost savings, revenue growth, profit increase and cash-flow improvement in the annual reports, and followed up with regular reports on progress. Here, “5-10-15-20” is shorthand for a 5% reduction in productions costs, 10% organic growth in sales, 15% organic growth in profit and 20% improvement in cash-flow and then inventory turns. The CEOs of other Six Sigma companies show similar consistency in their display of commitment.

Even before the first results start to come in at the headquarters, a high degree of personal faith and commitment from top-level management to the Six Sigma initiative are necessary. A good example is John F. Welch’s elaboration on his five-year plan for Six Sigma. In his speech at the GE 1996 Annual Meeting in Charlottesville, he makes it clear that “... we have set for ourselves the goal of becoming, by the year 2000, a Six Sigma quality company which means a company that produces virtually defect-free products, ser-

vices and transactions.” His speech is a landmark one for Six Sigma, and it is cited in full in Appendix A-5.

It is also the responsibility of top-level management to set “stretch goals” for the Six Sigma initiative. Stretch goals are tough and demanding, but are usually achievable. Some companies set the stretch goal for process performance at 6 sigma or 3.4 DPMO for all critical-to-customer characteristics. However, the goals can also be set incrementally, by stating instead the annual improvement rate in process performance. The industry standard is to reduce DPMO by 50% annually.

## *(2) Stakeholder involvement*

Stakeholder involvement means that the hearts and minds of employees, suppliers, customers, owners and even society should be involved in the improvement methodology of Six Sigma for a company. In order to meet the goal set for improvements in process performance and to complete the improvement projects of a Six Sigma initiative, top-level management commitment is simply not enough. The company needs active support and direct involvement from stakeholders.

Employees in a company constitute the most important group of stakeholders. They carry out the majority of improvement projects and must be actively involved. The Six Sigma management is built to ensure this involvement through various practices, such as training courses, project team activities and evaluation of process performance.

Suppliers also need to be involved in a Six Sigma initiative. A Six Sigma company usually encourages its key suppliers to have their own Six Sigma programs. To support suppliers, it is common for Six Sigma companies to have suppliers sharing their performance data for the products purchased and to offer them participation at in-house training courses in Six Sigma. It is also common for Six Sigma companies to help small suppliers financially in pursuing Six Sigma programs by inviting them to share their experiences together in report sessions of project team activities. The reason for this type of

involvement is to have the variation in the suppliers' products transferred to the company's processes so that most of the process improvement projects carried out on suppliers' processes would result in improvement of the performance.

Customers play key roles in a Six Sigma initiative. Customer satisfaction is one of the major objectives for a Six Sigma company. Customers should be involved in specific activities such as identifying the critical-to-customer (CTC) characteristics of the products and processes. CTC is a subset of CTQ from the viewpoint of the customers. Having identified the CTC requirements, the customers are also asked to specify the desired value of the characteristic, i.e., the target value and the definition of a defect for the characteristic, or the specification limits. This vital information is utilized in Six Sigma as a basis for measuring the performance of processes. In particular, the R&D part of a company should know the CTC requirements and should listen to the voice of customers (VOC) in order to reflect the VOC in developing new products.

## **2.3 Training Scheme and Measurement System**

### ***(1) Training scheme***

In any Six Sigma program, a comprehensive knowledge of process performance, improvement methodology, statistical tools, process of project team activities, deployment of customer requirements and other facets is needed. This knowledge can be cascaded throughout the organization and become the shared knowledge of all employees only through a proper training scheme.

There are five different fairly standardized training courses in Six Sigma. To denote these courses, Six Sigma companies have adopted the belt rank system from martial arts which is shown in Figure 2.2. There are the White Belts (WB), Green Belts (GB), Black Belts (BB), Master Black Belts (MBB) and Champions.

Course levels		Belts
Overall vision	☺	Champion
Most comprehensive	☺☺☺	Master Black Belt
Comprehensive	☺☺☺☺☺	Black Belt
Median	☺☺☺☺☺☺ ☺☺☺☺☺☺	Green Belt
Basic	☺☺☺☺☺☺☺☺☺ ☺☺☺☺☺☺☺☺☺	White Belt

**Figure 2.2.** Course levels and belts for Six Sigma training scheme

The WB course gives a basic introduction to Six Sigma. Typically, it is a 2–3 day course and is offered to all employees. It covers a general introduction to Six Sigma, framework, structure of project teams and statistical thinking. The GB course is a median course in content and the participants also learn to apply the formalized improvement methodology in a real project. It is usually a 1–2 week course, and is offered to foremen and middle management. The BB course is comprehensive and advanced, and aims at creating full-time improvement project leaders. Black Belts are the experts of Six Sigma, and they are the core group in leading the Six Sigma program. The duration of a BB course is around 4–6 months with about 20 days of study seminars. In-between the seminar blocks, the participants are required to carry out improvement projects with specified levels of DMAIC steps. The BB candidates are selected from the very best young leaders in the organization.

An MBB has BB qualifications and is selected from Black Belts who have much experience of project activities. An MBB course is most comprehensive as it requires the same BB training and additionally planning and leadership training. Champions are drivers, advocates and experienced

sources of knowledge on Six Sigma. These people are selected among the most senior executives of the organization. A Champion course is usually a 3–4 day course, and it concentrates on how to guide the overall Six Sigma program, how to select good improvement projects and how to evaluate the results of improvement efforts.

The number of people who are trained at the different levels depends on the size of company and its resources. A common guideline is to have one BB for every 100 employees, around 20 GBs for every BB, and 20 BBs for every MBB. Therefore, if a company has 10,000 people, a good guideline is that there should be 5 MBBs, 100 BBs, 2,000 GBs and the remaining people are WBs.

Most Six Sigma companies, and also consulting organizations, which offer these training courses typically issue a certificate to all participants successfully completing the courses. Just as the course contents differ among different Six Sigma companies, the certificates also differ in layout and content. After completing the courses, most companies require that GBs complete one improvement project and BBs three or four improvement projects annually. The consequence of not following these requirements would be withdrawal of the certificate.

## *(2) Measurement system*

A Six Sigma company should provide a pragmatic system for measuring performance of processes using a sigma level, ppm or DPMO. The measurement system reveals poor process performance and provides early indications of problems to come. There are two types of characteristics: continuous and discrete. Both types can be included in the measurement system. Continuous characteristics may take any measured value on a continuous scale, which provides continuous data. In continuous data, normally the means and variances of the CTQ characteristics are measured for the processes and products.

From the mean and variance, the sigma levels and process capability indices can be calculated.

Discrete characteristics are based on counts, such as yes/no, good/bad, which provide attribute data. A much larger number of observations is needed for a discrete characteristic compared to a continuous characteristic in measuring process performance by means of DPMO. A rule of thumb is to require at least 20 observations for assessing the performance of a continuous characteristic and at least 200 observations for a discrete characteristic.

The data for the characteristic selected for the Six Sigma measurement system is collected individually at predetermined time intervals such as hourly, daily, or weekly. Based on the data collected, the DPMO value for the individual characteristic is calculated. Although continuous data and discrete data need to be measured and analyzed differently, the results can be consolidated into one number for the process performance of the whole company. The performance of the individual characteristic included in the measurement system can be tracked over time, as can the consolidated value for the company's goods, services, projects and processes. Most Six Sigma companies make use of spreadsheets and databases to collect, analyze, and track results. Both standard software packages and tailor-made systems are used. The results, typically visualized in simple graphical illustrations such as a trend chart (see Chapter 4), are distributed within the company through intranet, newsletters, information stands and so on. Of particular importance is the consolidated DPMO value for the whole company. The measurement system brings process performance to the attention of the whole organization – simple to understand and easy to remember.

## **2.4 DMAIC Process**

The most important methodology in Six Sigma management is perhaps the formalized improvement methodology

characterized by DMAIC (define-measure-analyze-improve-control) process. This DMAIC process works well as a breakthrough strategy. Six Sigma companies everywhere apply this methodology as it enables real improvements and real results. The methodology works equally well on variation, cycle time, yield, design, and others. It is divided into five phases as shown in Figure 2.3. In each phase the major activities are as follows.

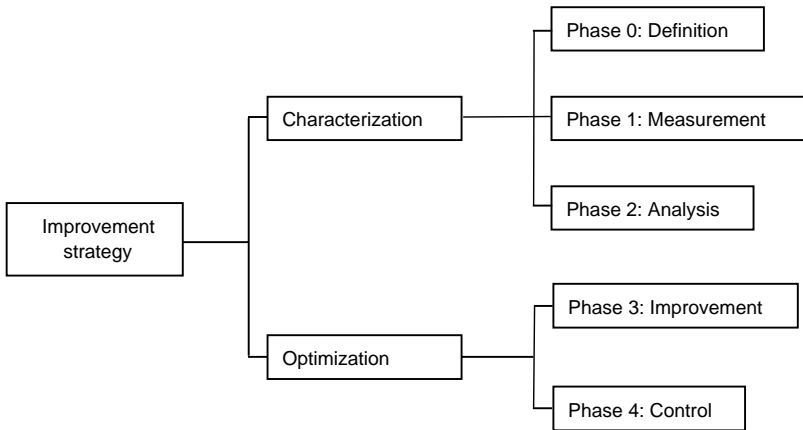

**Figure 2.3.** Improvement phases

**Phase 0: (Definition)** This phase is concerned with identification of the process or product that needs improvement. It is also concerned with benchmarking of key product or process characteristics of other world-class companies.

**Phase 1: (Measurement)** This phase entails selecting product characteristics; i.e., dependent variables, mapping the respective processes, making the necessary measurement, recording the results and estimating the short- and long-term process capabilities. Quality function deployment (QFD) plays a major role in selecting critical product characteristics.

**Phase 2: (Analysis)** This phase is concerned with analyzing and benchmarking the key product/process performance metrics. Following this, a gap analysis is often undertaken to identify the common factors of successful performance; i.e., what factors explain best-in-class performance. In some cases, it is necessary to redefine the performance goal. In analyzing the product/process performance, various statistical and basic QC tools are used.

**Phase 3: (Improvement)** This phase is related to selecting those product performance characteristics which must be improved to achieve the goal. Once this is done, the characteristics are diagnosed to reveal the major sources of variation. Next, the key process variables are identified usually by way of statistically designed experiments including Taguchi methods and other robust design of experiments (DOE). The improved conditions of key process variables are verified.

**Phase 4: (Control)** This last phase is initiated by ensuring that the new process conditions are documented and monitored via statistical process control (SPC) methods. After the “settling in” period, the process capability is reassessed. Depending upon the outcome of such a follow-on analysis, it may become necessary to revisit one or more of the preceding phases.

The flowchart for DMAIC quality improvement process is sketched in Figure 2.4.

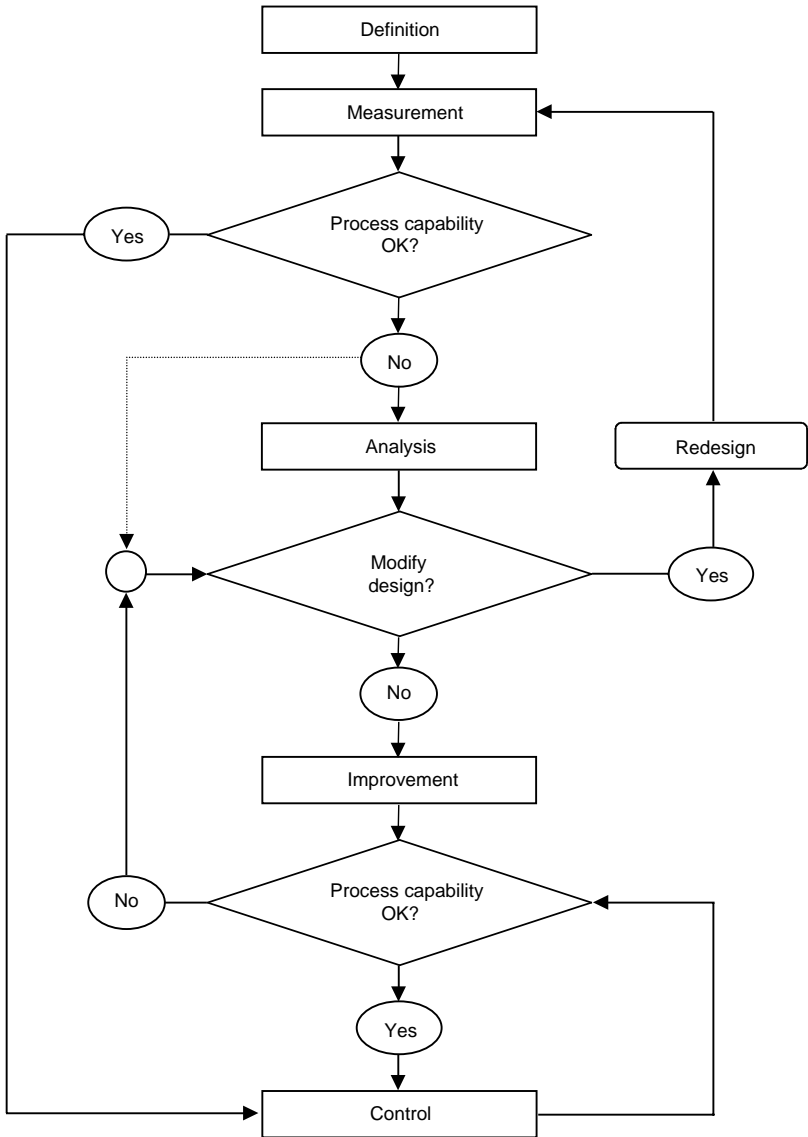

Figure 2.4. Flowchart of DMAIC process

## 2.5 Project Team Activities

### *(1) An ideal way to introduce Project Team Activities*

For a company which wishes to introduce Project Team Activities as the management strategy, the author would like to recommend the following seven-step procedure.

- 1) Organize a Six Sigma team and set up the long-term Six Sigma management vision for the company.
- 2) Start Six Sigma education for Champions first.
- 3) Choose the area for which a Six Sigma process is to be introduced first.
- 4) Start the education for Green Belts (GB) and Black Belts (BB).
- 5) Deploy CTQs for all areas concerned. Appoint a few or several BBs as full-time project team leaders and ask them to solve some important CTQ problems.
- 6) Strengthen the infrastructure for Six Sigma, such as statistical process control (SPC), knowledge management (KM), and database management system.
- 7) Designate a “Six Sigma Day” each month, and have the top-level management check the progress of Six Sigma project teams, and organize presentations or awards for accomplishments, if any.

First of all, a few or several members should be appointed as a Six Sigma team to handle all Six Sigma activities. Subsequently, the team should set up the long-term Six Sigma vision for the company under the supervision of top-level management. This is the first and the most important task for the team. It is said that this is the century of 3Cs, which are Change, Customer and Competition, for quality. The Six Sigma vision should match these 3Cs well. Most importantly, all employees in the company must agree to and respect this vision.

Second, Six Sigma can begin with proper education for all levels of the company's employees. The education should begin with the top management and directors (Champions). If Champions do not understand the real meaning of Six Sigma, there is no way for Six Sigma to be disseminated within the company. Following the education of Champions, the training for GB, BB, and MBB (Master Black Belts) must be conducted in that sequence. However, the MBB education is done usually by professional organizations.

Third, Six Sigma can be divided into three parts according to its characteristics. They are Design for Six Sigma (DFSS) for the R&D area, Six Sigma for manufacturing processes, and Transactional Six Sigma (TSS). DFSS is often called R&D Six Sigma. It is not easy to introduce Six Sigma to all areas at the same time. In this case, the CEO should decide the order of introduction to those three areas. Usually it is easy to introduce Six Sigma to manufacturing processes first, followed by the service areas and the R&D areas. However, the order really depends on the circumstances of the company at the time.

Fourth, GB and BB educations are the most important ingredients for Six Sigma success.

Fifth, deploy CTQs for all departments concerned. These CTQs can be deployed by policy management or by management by objectives. When the BBs are born, some important CTQ problems should be given to these BBs to solve. In principle, the BB should be the project leaders and work as full-time workers for quality innovation.

Sixth, in order to firmly introduce Six Sigma, some basic infrastructure is necessary. The tools required include SPC, MRP (material requirement planning), KM, and DBMS. In particular, efficient data acquisition, data storage, data analysis and information dissemination systems are necessary.

Lastly, a "Six Sigma Day" each month must be designated. On this day, the CEO must check the progress of Six Sigma

project teams personally. On this day, all types of presentations of Six Sigma results can be made, and rewards can be given to the persons who performed excellent jobs in support of the Six Sigma initiative.

## *(2) Problem-solving processes for project activities*

The original Six Sigma process developed for problem-solving at Motorola is MAIC, which means measurement, analysis, improvement, and control. Later, DMAIC instead of MAIC was advocated at GE where D stands for definition. MAIC or DMAIC is mostly used as a unique problem-solving process in manufacturing areas. However, with DFSS, there are several proposed processes as follows.

- 1) DMADV (Define – Measure – Analyze – Design – Verify). MADV was suggested by Motorola for DFSS, and D was added to it for definition. DMADV is similar to DMAIC.
- 2) IDOV (Identify – Design – Optimize – Validate). This was suggested by GE and has been used most frequently in practice.
- 3) DIDES (Define – Initiate – Design – Execute – Sustain). This was suggested by Qualtec Consulting Company.

It seems that the above problem-solving processes for manufacturing and R&D are not quite suitable for service areas. The author believes that DMARIC (Define – Measure – Analyse – Redesign – Implement – Control) is an excellent problem-solving process of TSS for non-manufacturing service areas. Here, the “redesign” phase means that the system for service work should be redesigned in order to improve the service function.

**(3) Difference between project teams and quality circles**

In Six Sigma, the project teams leading by BBs are the backbone of group activities. However, in TQC or TQM, quality circles constitute the backbone of group activities. There are some basic differences between these two teams as shown in Table 1. In the old management strategies of TQC and TQM, there are usually two types of team efforts, namely, the task-force-team and the quality circle team. The task-force-team mainly consists of engineers and scientists, and the quality circle team consists of the line operators. However, in Six Sigma, these two teams are merged into one, called the “project team,” whose leader is usually a BB. For theme selection and problem-solving flow, the differences are also listed in Table 1.

Depending on management policy, it is permissible for a company to have project teams and quality circle teams at the same time under the banner of Six Sigma. However, care should be exercised in controlling the two types of teams.

**Table 2.1.** Differences between project team and quality circle

Classification	Project team	Quality circle
Organization	Engineers (or scientists) + operators one BB + several GBs	Operators
Theme selection	Top-down, company CTQs	Bottom-up, self-selection
Problem-solving, flow	DMAIC, DMADV, IDOV, DMARI	PDCA

**(4) How to select project themes?**

As shown in Table 2.1, the project themes are selected essentially by a top-down approach, and company CTQs are nominated as themes most of the time. The deployment method in order to select project themes is shown in Figure 2.5.

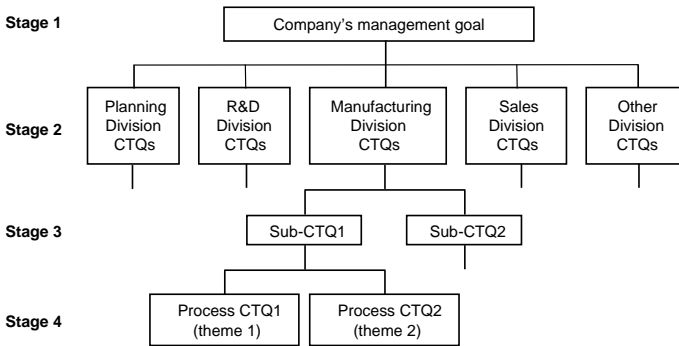

**Figure 2.5.** Deployment for selection of project themes

For example, suppose that one of the company's management goals is to improve production capability without further investment. For this particular goal, each division must have its own CTQs. Suppose that the manufacturing division has such CTQs as machine down-time and rolled throughput yield (RTY). For instance, for the machine down-time, there may be more than two sub-CTQs: heating machine down-time, cooling machine down-time, and pump down-time. For the sub-CTQ of heating machine down-time, process CTQ1 (theme 1) could be "reduction of heating machine down-time from 10 hours/month to 5 hours/month," and process CTQ2 (theme 2) could be "10% improvement of heating process capability."

## 2.6 Design for Six Sigma

### (1) *DFSS process*

Based on the author's consulting experiences, it is not easy for a company to adopt DFSS. However, once it is fully adopted, the net effect and cost savings can be enormous. Figure 2.6 shows a DFSS process which is quite effective in a research institute. Samsung and LG Electronics are using this process.

(2) Major activities in IDOV steps

In Figure 2.6, we see a typical DFSS process and the IDOV steps. The major activities and methodologies used in each step can be found in Figure 2.7.

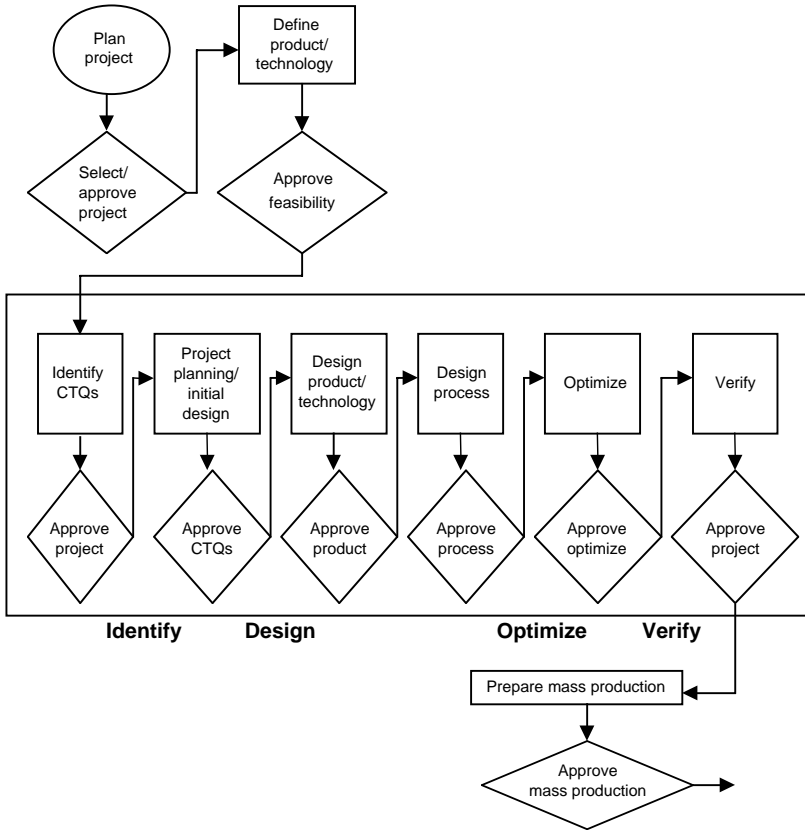

Figure 2.6. A typical DFSS process

There are several problems to be tackled for DFSS implementation. These problems must be solved for a smooth introduction of DFSS. They are as follows.

- 1) Researchers tend to resist introduction of any new scientific methodology into their research activities.

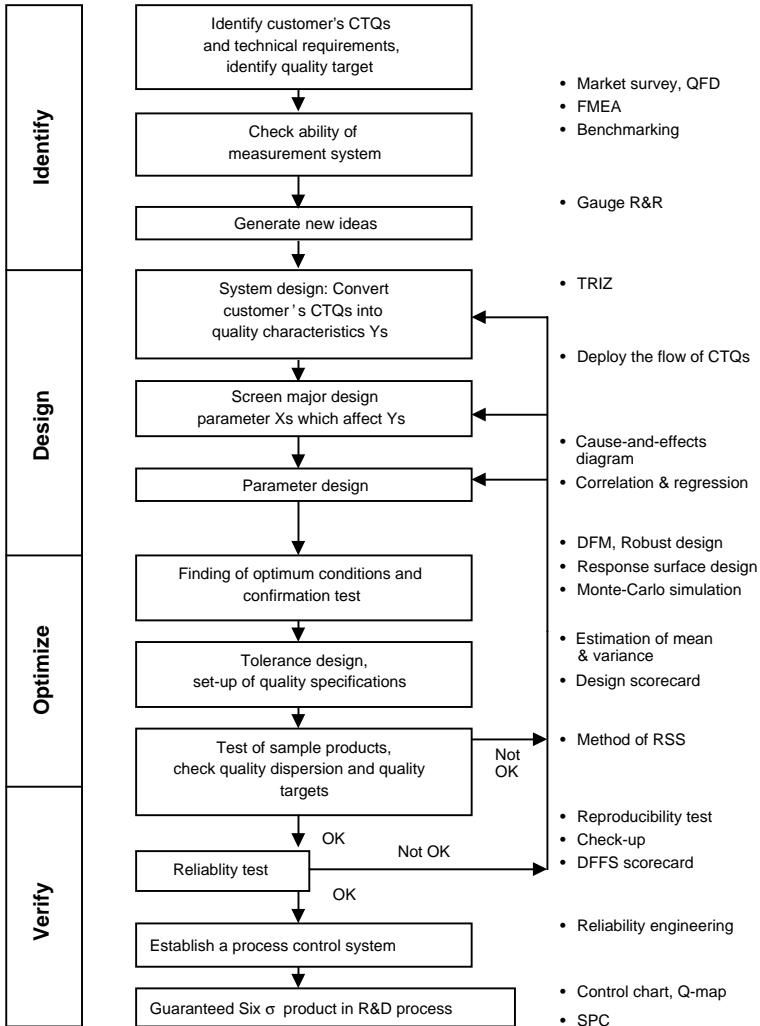

Figure 2.7. Major activities and methods in each step of IDOV

Hence, their understanding and cooperation or approval should be sought before introducing the DFSS into their activity.

- 2) GB or BB education/training is especially necessary, since there are many scientific tools for R&D including QFD, DOE, simulation techniques, robust designs and regression analysis. For such education/training, textbooks that contain real and practical examples should be carefully prepared in order to make researchers understand why DFSS is a very useful tool.
- 3) Project team activities are usually not popular in R&D departments. In this case, BBs should be assigned as full-time project leaders. It is desirable that the company gives time, space and necessary financial support to the BBs to solve the projects.

The author has been interested in DFSS, and his views and detailed explanation are given in Park and Kim (2000), and Park, et. al. (2001).

## **2.7 Transactional/Service Six Sigma**

As mentioned earlier, Six Sigma in a big manufacturing company is composed of three parts: DFSS, manufacturing Six Sigma, and Transactional Six Sigma (TSS). However, there are many service companies that deal only with service work such as insurance, banking and city government. In this section, TSS including service Six Sigma will be discussed.

### ***(1) Measurement and project team activities***

Many companies have learned a key lesson in their implementation of Six Sigma: successful outcomes are very often produced in transactional processes such as sales, purchasing, after-service, and financing. However, arriving at a meaningful definition of defects and collecting insightful metrics are often the biggest challenges in transactional and service processes. Pro-

jects involving these processes sometimes lack objective data. When the data do exist, the practitioner is usually forced to work with attribute data such as pass/fail requirements or number of defects. Teams should strive for continuous data over attribute data whenever possible, since continuous data provide more options in terms of the available statistical tools and yield more information about the process with a given sample size.

In transactional/service projects, a process may be defined and a goal can be set but frequently without a set of known specification limits. Setting a goal or soft target as a specification limit for the purpose of determining the process capability/performance indices can yield only questionable results. It requires persistence and creativity to define the process metrics that yield true insight into transactional/service processes. However, many of the “low-hanging fruit” projects can be successfully attacked with some of the seven QC tools: cause-and-effect analysis, histogram, Pareto diagram, scatter-diagram, or simple graphs. These tools can help teams determine where to focus their efforts initially while establishing the data collection system to determine the root cause of the more difficult aspects of a project.

The correlation/regression or DOE (design of experiments) techniques are frequently associated with manufacturing processes, but they can provide significant benefits to transactional/service projects as well. A well-designed DOE can help establish process parameters to improve a company’s efficiency and service quality. The techniques offer a structured, efficient approach to experimentation that can provide valuable process improvement information.

## *(2) Flow of project team activities*

As mentioned earlier in Section 2.5, the suggested flow of the project team activities in transactional/service processes is DMARIC. At each step, the actions shown in Table 2.2 are recommended.

**Table 2.2.** Suggested actions in each step of DMARIC project team activities

Step	Action
<b>Definition (D)</b>	<ol style="list-style-type: none"> <li>1. Define the scope and surrounding conditions of the project.</li> <li>2. Identify critical customer requirements and CTQy's.</li> <li>3. Check the competitiveness of the CTQy's by benchmarking.</li> <li>4. Describe the business impact of the project.</li> </ol>
<b>Measurement (M)</b>	<ol style="list-style-type: none"> <li>1. Identify the project metrics for the CTQy's.</li> <li>2. Measure the project metrics, and start compiling them in time series format by reflecting the long-term variabilities.</li> <li>3. Address financial measurement issues of project.</li> </ol>
<b>Analysis (A)</b>	<ol style="list-style-type: none"> <li>1. Create a process flowchart/process map of the current process at a level of detail that can give insight into what should be done differently.</li> <li>2. Create a cause-and-effect diagram or matrix to identify input variables, CTQx's, that can affect the process output, CTQy.</li> <li>3. Rank importance of input variables using a Pareto diagram.</li> <li>4. Conduct correlation, regression and analysis of variance studies to gain insight into how input variables can impact output variables.</li> </ol>
<b>Redesign (R)</b>	<ol style="list-style-type: none"> <li>1. Consider using DOEs to assess the impact of process change considerations within a process.</li> <li>2. Consider changing work standards or process flow to improve process quality or productivity.</li> <li>3. Determine optimum operating windows of input variables from DOEs and other tools.</li> </ol>
<b>Implement (I)</b>	<ol style="list-style-type: none"> <li>1. Set up the best work standards or process flow.</li> <li>2. Test whether the optimum operating windows of input variables are suitable, and implement them.</li> <li>3. Verify process improvements, stability, and performance using runcharts.</li> </ol>
<b>Control (C)</b>	<ol style="list-style-type: none"> <li>1. Update control plan. Implement control charts to check important output and input variables.</li> <li>2. Create a final project report stating the benefits of the project.</li> <li>3. Make the project report available to others within the organization.</li> <li>4. Monitor results at the end of 3 and 6 months after project completion to ensure that project improvements are maintained.</li> </ol>

## 3. Six Sigma Experiences and Leadership

---

### 3.1 Motorola: The Cradle of Six Sigma

Motorola was established by Paul V. Galvin in 1929. Starting with car radios, the company thrived after the Second World War and moved its product range via television to high-technology electronics, including mobile communications systems, semiconductors, electronic engine controls and computer systems. Today, it is an international leading company with more than \$30 billion in sales and around 130,000 employees. Galvin succeeded his father as president in 1956 and as CEO and chairman in 1964.

In the late 1970s, Galvin realized that Motorola was in danger of being buried by the Japanese on quality, and he received strong evidence of actual customer dissatisfaction. First in 1981, he decided to make total customer satisfaction the fundamental objective of his company. He set a goal of a ten-fold improvement in process performance over the next five years. He started empowering people with the proper tools, and he requested help from quality experts such as Joseph M. Juran and Dorian Shainin. Juran provided methods on how to identify chronic quality problems and how to tackle the problems by improvement teams. Shainin helped them with statistical improvement methodologies such as design of experiments and statistical process control.

During 1981–1986, seminar series were set up and some 3,500 people were trained. At the end of 1986, Motorola had invested \$220,000, whereas cost savings topped \$6.4 million. The intangible benefits included real improvements in performance and customer satisfaction, alongside genuine interest from top-level management in statistical improvement methodologies and enthusiastic employees.

Despite such incredible success, Motorola was still facing a tough challenge from Japan. The Communication Sector,

Motorola's main manufacturing division, presented their ideas for an improvement program to Mr. Galvin in a document titled "Six Sigma Mechanical Design Tolerancing". At that time, Motorola possessed data indicating that they were performing at 4 sigma, or 6,800 DPMO. By improving process performance to 6 sigma, i.e. 3.4 DPMO, in the following five years, the Communication Sector estimated that the gap between them and the Japanese would diminish.

Galvin, it was said, liked the name Six Sigma because it sounded like a new Japanese car and he needed something new to attract attention. In January 1987, he launched this new, visionary strategic initiative called "Six Sigma Quality" at Motorola emphasizing the following milestones:

- Improve product and service quality by a factor of 10 by 1989
- Achieve at least 100-fold improvement by 1991
- Achieve 6 sigma quality level by 1992

To ensure that the organization could accomplish the milestones of the Six Sigma program, an aggressive education campaign was launched to teach people about process variation and the necessary tools to reduce it. Spending upwards of \$50 million annually, employees at all levels of the organization were trained. Motorola University, the training center of Motorola, played an active role in this extensive Six Sigma training scheme. The company has excellent in-house experts who greatly contributed to the drive and conceptual developments of Six Sigma. They included the likes of Bill Smith, Michael J. Harry and Richard Schroeder. Smith set up the statistics, while Harry and Schroeder helped management and employees put these to work for them.

Motorola focused on top-level management commitment to reinforce the drive for Six Sigma, convincing people that Six Sigma was to be taken seriously. The general quality policy at that time also reflected the company's Six Sigma initiative. For example, the quality policy for the Semiconductor Products Sector explicitly states the quality policy as follows.

“It is the policy of the Motorola Semiconductor Products Sector to produce products and provide services according to customer expectations, specifications and delivery schedule. Our system is a six sigma level of error-free performance. These results come from the participative efforts of each employee in conjunction with supportive participation from all levels of management.”

Savings estimates for 1988 from the Six Sigma program totalled \$480 million from \$9.2 billion in sales. The company soon received external recognition for its Six Sigma drive. It was one of the first companies to capture the prestigious Malcolm Baldrige National Quality Award in 1988. The following year, Motorola was awarded the Nikkei Award for manufacturing from Japan. Motorola adopted “Six Steps to Six Sigma” for guiding the spread of process improvement which is shown in Table 3.1. Process was greatly improved throughout the company both in manufacturing and non-manufacturing areas of operation.

**Table 3.1.** Six Steps to Six Sigma applied by Motorola for process improvement

Manufacturing area	Non-manufacturing area
<ul style="list-style-type: none"> <li>• Identify physical and functional requirements of the customer.</li> <li>• Determine characteristics of product critical to each requirement.</li> <li>• Determine, for each characteristic whether controlled by part, process, or both.</li> <li>• Determine process variation for each characteristic.</li> <li>• Determine process variation for each characteristic.</li> <li>• If process performance for a characteristic is less than 6 sigma, then redesign materials, product and process as required.</li> </ul>	<ul style="list-style-type: none"> <li>• Identify the work you do (your product).</li> <li>• Identify who your work is for (your customer).</li> <li>• Identify what you need to do your work, and from whom (your supplier).</li> <li>• Map the process.</li> <li>• Mistake-proof the process and eliminate delays.</li> <li>• Establish quality and cycle time measurements and improvement goals.</li> </ul>

Six Sigma at Motorola became a corporate success story that had reached its targets in most areas by the deadline of 1992. CEO George Fisher is quoted as having said in 1993: “We have reached the Six Sigma target in many areas, but not as a company. Right now, manufacturing is probably at around five sigma levels. We have launched the ‘Beyond Six Sigma’ program so that those businesses that have succeeded in Six Sigma keep going and aim to improve our defect level 10 times every two years.” He also explained that: “We have saved a significant amount of the costs of manufacturing, \$700 million during 1991, and a total of \$2.4 billion since the beginning of our Six Sigma thrust.”

Motorola is still applying Six Sigma. However, the company launched a renewal program besides Six Sigma in 1998 influenced by the financial crisis and recession in Asia, one of its most important markets. The new program had four key objectives:

- Global leadership in core businesses
- Total solutions through partnerships
- Platforms for future leadership
- Performance excellence

Within the last objective, namely performance excellence, Six Sigma quality and cycle time reductions have been emphasized.

### **3.2 General Electric: The Missionary of Six Sigma**

General Electric (GE) has the unique distinction of being at the top of the Fortune 500 companies in terms of market capitalization. Market capitalization means that if someone multiplies GE’s outstanding shares of stock by its current market price per share, GE is the highest-valued company listed on all U.S. stock exchanges. The monetary value exceeds the gross domestic product of many nations around the world.

Even though Motorola is the founder of Six Sigma, GE is the company which has proven that Six Sigma is an exciting management strategy. GE is indeed the missionary of Six

Sigma. GE began its Six Sigma program in 1995, and has achieved remarkable results since then. An annual report of GE states that Six Sigma delivered more than \$300 million to its operating income. In 1998, this number increased to \$750 million. At the GE 1996 Annual Meeting, CEO Jack Welch described Six Sigma as follows: “Six Sigma will be an exciting journey and the most difficult and invigorating stretch goal we have ever undertaken. ... GE today is a quality company. It has always been a quality company. ... This Six Sigma will change the paradigm from fixing products so that they are perfect to fixing processes so that they produce nothing but perfection, or close to it.” The full text of the speech of Jack Welch at the GE 1996 Annual Meeting in Charlottesville, Virginia on April 24, 1996 is attached in Appendix A-5. This speech is regarded as a milestone in Six Sigma history.

GE listed many examples as typical Six Sigma benefits (General Electric, 1997). A few of them are as follows:

- GE Medical Systems described how Six Sigma designs have produced a 10-fold increase in the life of CT scanner X-ray tubes – increasing the “up-time” of these machines and the profitability and level of patient care given by hospitals and other health care providers.
- Super-abrasives – our industrial diamond business – described how Six Sigma quadrupled its return on investment and, by improving yields, is giving it a full decade’s worth of capacity despite growing volume – without spending a nickel on plant and equipment capacity.
- The plastic business, through rigorous Six Sigma process work, added 300 million pounds of new capacity (equivalent to a free plant), saved \$400 million in investment, and was to save another \$400 million by 2000.

Six Sigma training has permeated GE, and experience with Six Sigma implementation is now a prerequisite for promotion to all professional and managerial positions. Executive compensation is determined to a large degree by one’s proven Six

Sigma commitment and success. As of 1998, GE boasts slightly under 4,000 full-time, trained BBs and MBBs. They also claim to have more than 60,000 part-time GBs who have completed at least one Six Sigma project (Pyzdek, 1999).

### **3.3 Asea Brown Boveri: First European Company to Succeed with Six Sigma**

Asea Brown Boveri (ABB), the Swiss-Swedish technology group, was probably the first European multinational to introduce Six Sigma. Most of the following information about ABB comes from the reference, Magnusson et. al. (2000). ABB has 160,000 employees in more than 100 countries. It serves customers in five segments: Power Transmission and Distribution; Automation; Oil, Gas and Petrochemicals; Building Technologies; and Financial Services. Under the leadership of President and CEO Percy Barnevik, now acting chairman of the board, and his successor Goran Lindahl, the company has thrived. Mr. Lindahl states in the 1999 Annual Report: “We aim to work so closely with our customers that we become part of their business, and they part of ours – sharing the endeavor of building excellence, efficiency and productivity.”

Six Sigma was launched in the segment of Power Transmission and Distribution in 1993 on a voluntary basis for the plants. This segment counts for around 7,000 employees in 33 manufacturing plants in 22 countries. The Six Sigma program has remained consistent over the years, the drive has matured and commitment is generated by successful results. Six Sigma has been implemented by all transformer plants and has spread into other ABB businesses, suppliers and customers because of its own merits.

The overall objective of ABB at the beginning of Six Sigma was customer focus in addition to cost reduction, cycle time reduction and self-assessment programs. Since 1993, several initiatives have been attempted with the objective of finding a pragmatic approach. In late 1993, ABB asked Michael J. Harry, a Six Sigma architect at Motorola, to join as vice president of

ABB, and asked him to be responsible for Six Sigma implementation. During his two years with ABB, he devoted much of his time to the business area for power transformers. His emphasis was on cost-saving results, performance measurements, training courses and a formalized improvement methodology. It was his consistent philosophy that Six Sigma should be carried out based on voluntary participation and active involvement. His message was clear: introduction in each plant was a decision to be made by the local plant management. It was not forced on any plant by the business area headquarters.

Plants interested in Six Sigma sent employees to BB courses at the headquarters and substantial cost savings were achieved immediately by project team activities led by trained BBs. The first BB course was held in 1994. Since then, more than 500 BBs have graduated from the business area's Six Sigma training courses. The BB course has been made much more demanding over the years and at an early stage significant cost savings were required in the mandatory homework projects.

In the early days of Six Sigma at ABB, plants started to identify key process and product characteristics to be assessed and created measurement cards to be used for data collection in workshops. They developed a database for data storage and reported DPMO values to the headquarters. It became clear that a specific process in one plant could be compared to similar processes of other plants. "This is really benchmarking" and "DPMO values disclose problems" were obvious conclusions. The characteristics were readily available, both in terms of a single process and a combination of processes. This was also true for the improvement rate. Efforts were very successful in developing a standard set of characteristics to be measured in the production of transformers across plants.

Six Sigma has become ingrained in the operation. Over the years, success has bred further success. More than half of all plants apply Six Sigma actively with excellent results, whereas the remaining plants have focused more on training and measurements than on project improvement work. Plants

were not forced to introduce Six Sigma, but the reporting and measurement of process performance, by means of DPMO, were made mandatory.

Plants have been very much pleased with their Six Sigma programs. A quality manager in Scotland states that “Six Sigma is the strongest improvement approach that has been around for a long time.” The Six Sigma initiative at ABB has generated a great deal of positive feedback from customers and suppliers, both to the headquarters and to the individual plants. ABB achieved remarkable results through the application of Six Sigma. The results include reduction of process variation, leading to products with fewer defects, increased yields, improved delivery precision and responsiveness, as well as design improvements.

Most projects have been centered on manufacturing processes, but also a good number of projects in non-manufacturing processes have been completed. They include front-end clearance, invoicing, reducing ambiguity in order processing, and improving production schedules.

Some of the key critical reasons for the success of Six Sigma at ABB are complex and inter-related. However, 10 secrets of success stand out and can be shared. Some of these may be specific to ABB, but we believe they share a broad common ground.

- 1) **Endurance:** Endurance from key people involved in the initiative is essential – CEO, Champion and BBs. The CEO as the number one believer, the Champion as the number one driver, and the BBs as the number one improvement experts.
- 2) **Early cost reductions:** For all plants launching Six Sigma the early improvement projects have brought confidence and determination.
- 3) **Top-level management commitment:** The top-level management has dedicated the time, attention and resources needed to achieve the goals set - commitment put into practice.

- 4) **Voluntary basis:** Voluntary basis has enabled Six Sigma to grow on its own merits and not as a forced compliance.
- 5) **Demanding BB course:** The BB course held at the headquarters has been thorough and demanding. It has been a vehicle for deployment and brings the Six Sigma framework and improvement methodology into the company.
- 6) **Full-time BBs:** ABB has utilized full-time BBs which are preferable to part-time BBs. One major reason is that a full-time BB has enough time to dedicate to carrying out and following up improvement projects. After completing a few projects, a BB moves back into operations and become a part-time BB.
- 7) **Active involvement of middle managers:** Active involvement of middle managers who are usually BBs or GBs is essential. They are in fact the backbone of improvement efforts.
- 8) **Measurement and database building:** Measurements and measurement systems are the important basis of Six Sigma. In addition to these, database building and information utilization are also a key factor of Six Sigma success. ABB did excellent jobs on these.
- 9) **One metric and one number:** One metric on process performance presents one consolidated number for performance such as sigma level or DPMO. Such simplicity effectively reduces complacency, which is the archenemy of all improvement work.
- 10) **Design of experiments:** Simple design of experiments such as factorial designs are successfully used at ABB. Factorial experiments are well utilized today, either as a stand-alone approach or combined with the seven QC tools.

### **3.4 Samsung SDI: A Leader of Six Sigma in Korea**

#### **(1) Introduction**

The First National Quality Prize of Six Sigma was given to two companies. One is Samsung SDI and the other is LG Electronics, which are virtually the leaders of Six Sigma in Korea. Samsung SDI is introduced in this section, and LG Electronics will be introduced in the next section. All statistics related to Samsung SDI are based on its “Explanation book of the current status of Six Sigma” which was published in 2000 when it applied for the National Quality Prize of Six Sigma.

Samsung SDI was founded in 1970 as a producer of the black/white Braun tube. It began to produce the color Braun tube from 1980, and now it is the number one company for braun tubes in the world. The market share of Braun tubes is 22%. The major products are CDT (color display tube), CPT (color picture tube), LCD (liquid crystal display), VFD (vacuum fluorescent display), C/F (color filter), li-ion battery and PDP (plasma display panel). The total sales volume is about \$4.4 billion and the total number of employees is about 18,000 including 8,000 domestic employees. It has six overseas subsidiaries in Mexico, China, Germany, Malaysia and Brazil.

#### **(2) Why Six Sigma?**

Since its founding in 1970, it has employed several quality management strategies such as QC, TQC/TPM, TQM/ISO9000, and PI as shown in Figure 3.1. In 1996, it began PI as the beginning stage of Six Sigma. Note that the direction of evolution in management strategies is from manufacturing areas to all areas of the company, and from product quality/small group activities to process innovation and redesign.

Product quality/small group activity → Process innovation & redesign

Scope of participation	Product quality	Small group activities, policy deployment	Standard management	Customer-oriented process redesign	Participation of all areas
Transactional areas				PI	Six Sigma
Marketing, R&D sales, purchasing					
Accounting					
Material, facility					
Manufacturing areas	QC	TQC/TPM	TQM/ISO9000		
Beginning	1970	1984	1992	1996	

\*\* QC=quality control, TQC=total quality control, TPM=total productivity maintenance, TQM=total quality management, ISO=International Organization for Standardization, PI=process innovation

**Figure 3.1.** Evolution of quality management strategies in Samsung SDI

The necessity of PI and Six Sigma stems from the problems of the company as shown in Figure 3.2. The problems were in the large quality variations in many products, repeated occurrences of the same defects, high quality costs (in particular, high failure costs), insufficient unified information for quality and productivity, manufacturing-oriented small group activities, and infrequent use of advanced scientific methods. The company concluded that the directions for solving these problems lay in scientific and statistical approaches for product quality, elimination of waste elements for process innovation, and continuous learning system for people. These directions in turn demanded a firm strategy for a complete overhaul, implying a new paradigm shift to Six Sigma.

Samsung SDI made a contract with SBTI (Six Sigma Break-through Inc.) for Six Sigma consultation in 1999. It was a one-year, \$3.4 million contract in which SBTI was supposed to help the company in every aspect of Six Sigma.

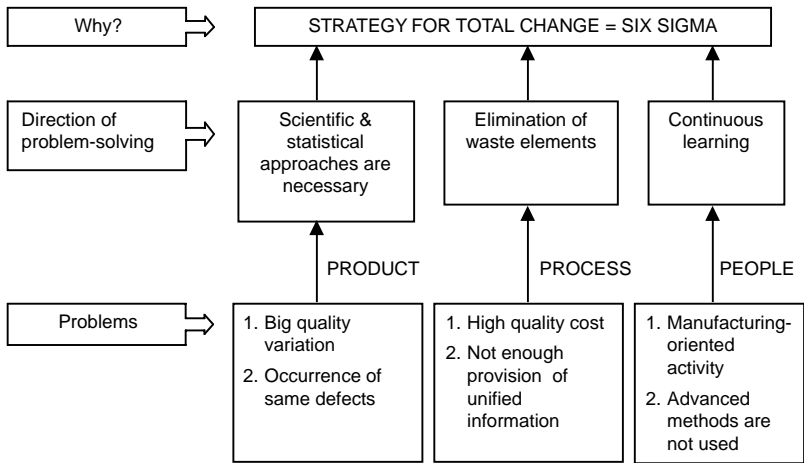
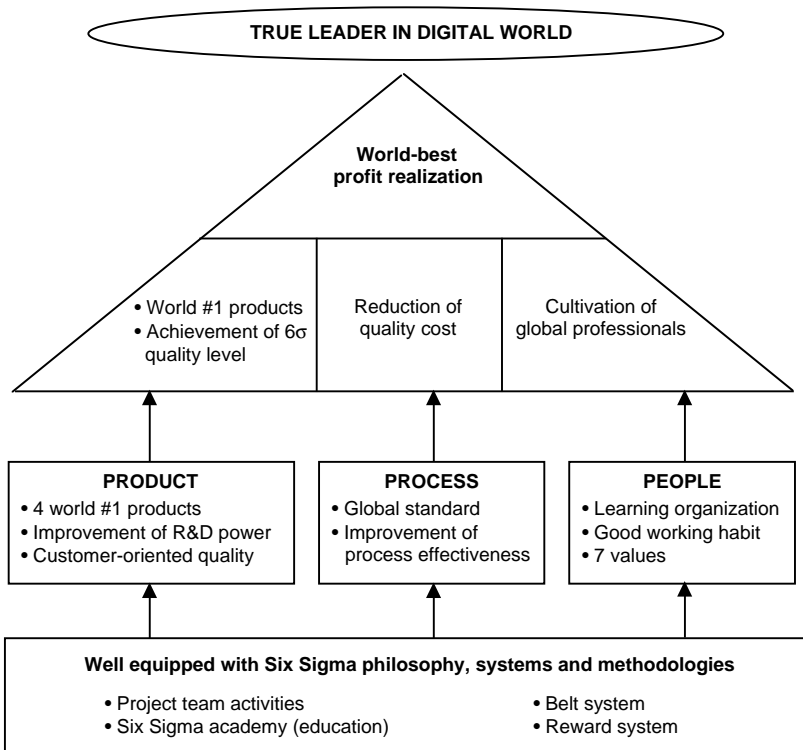

Figure 3.2. The necessity of Six Sigma

### (3) Vision of Six Sigma

The CEO of Samsung SDI, Son Wook, declared the slogan “True leader in digital world” as the Six Sigma vision at the end of 1996. The definition of Six Sigma in the company is “Six Sigma is the management philosophy, strategy and tool which achieves innovative process quality and development of world number one products, and which cultivates global professional manpower, and a way of thinking and working from the viewpoint of customer satisfaction.” The company demonstrates its vision as seen in Figure 3.3. In this figure, “Seven values” indicates vision, customer, quality, innovation, communication, competency and integrity. These values are in fact “the principles of action behavior” by which the employees are working in the company.



**Figure 3.3.** The vision of Six Sigma

#### (4) Major implementation of Six Sigma

##### (a) Realization of Champion leadership

Six Sigma is basically a top-down management tool. For implementation of Six Sigma, executive officers (i.e., Champions) should be the leaders of Six Sigma. In Samsung SDI, the following points have been implemented for Champion leadership.

- Champion education: all Champions take the Champion education course of four days, and they obtain the GB certification.

- **Champion planning:** Each Champion is supposed to plan a “Six Sigma roadmap” for his or her division twice a year. The Champion selects the themes of projects, and he/she supervises the Six Sigma plan for his/her division.
- **Champion day:** One day each month is designated as the Champion day. On this day, the Champions wear Six Sigma uniform, and discuss all kinds of subjects related to Six Sigma. Examples of Champion planning, best practice of Champion leadership, and best practice of BB projects are presented on this day.

(b) Project selection and implementation

Projects are selected by considering the company 6Y, which comprise company-wide CTQs, and each division’s goal and objective. As of 2000, the company 6Y are as shown in Table 3.2.

**Table 3.2.** Matrix mapping for project selection

Division's goal and object	Rate of importance	Company 6Y					
		Improvement of R&D	Improvement of marketing	Customer quality	Global management	30% improvement of effectiveness	SDI's 7 values
Customer satisfaction	2	3	1	2	3	1	1
Process	1	2	1	2	3	2	1
Learning	0.5	1	3	2	1	1	3
Financial achievement	1	1	2	3	1	1	1
Sum		9.5	6.5	12.0	10.5	5.5	5.5

According to this matrix mapping, the customer quality gets the highest mark, 12.0, hence the first priority for project selection is given to the company Y, customer-oriented quality. Then several project themes for this particular division can be chosen to achieve this company Y.

(c) Implementation of DFSS

The development system of Samsung SDI is based on E-CIM (engineering computer integrated manufacturing). E-CIM is a tool for maximizing the company’s competitiveness from the viewpoint of customer demand through efficient development process, technology standardization, PDM (product data management) and DR (design review). The DFSS process of Samsung SDI follows the IDOV (identify, design, optimize, verify) process, and after each step, DR helps to validate the process as shown in Figure 3.4.

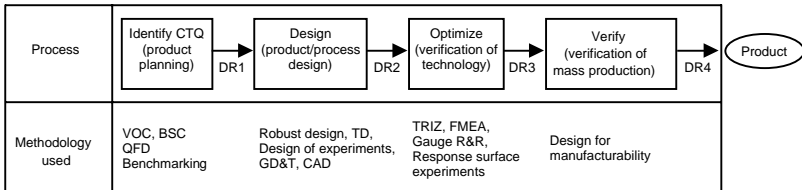

Figure 3.4. DFSS process

There are four different types of design review (DR). Each one reviews and validates the previous immediate step. For instance, DR1 reviews the product planning and decides whether DFSS process can flow to the next step or not.

(d) Manpower cultivation

Six Sigma education really began from 1999, when 1,228 GBs, 30 BBs, and 9 MBBs were cultivated. However, in 2000, 62 Champions, 44 MBBs, 192 BBs, 1,385 GBs and WBs out of all employees (total 7,818) were educated. This meant that 2.8% of all employees were BBs, and 33.4% of all employees were GBs, which are relatively high percentages. The belt system ran as shown in Table 3.3.

Full-time BBs are the backbone of Six Sigma management. As soon as a BB completes the BB education course, he/she becomes a “nominated BB.” When he completes two BB projects, he/she becomes a “certified BB” or “full-time BB” depending on his division’s situation. If a BB becomes a

full-time BB, he/she is supposed to spend all of their time working on his/her project with several GBs. Usually, his/her mission as a full-time BB lasts one year. After one year, his/her performance is evaluated. If he/she meets the maintenance standard, he/she can be a full-time BB once again for the next year. However, if he/she cannot meet the maintenance standard, he/she should be a certified BB or nominated BB for the next year.

**Table 3.3.** Belt system: Qualification and maintenance

Belt	Class	Qualification	Maintenance standard	Effective period
MBB	Full-time	<ul style="list-style-type: none"> <li>Full-time project supervisor</li> <li>Graduate of BB and MBB courses</li> <li>Supervision of at least 3 BB projects</li> </ul>	<ul style="list-style-type: none"> <li>Full-time Six Sigma supervision</li> <li>Supervision of at least 6 BB projects</li> </ul>	One year
	Certified	<ul style="list-style-type: none"> <li>Part-time project supervisor</li> <li>Graduate of BB and MBB courses</li> <li>Supervision of at least 3 BB projects</li> </ul>	<ul style="list-style-type: none"> <li>Part-time Six Sigma supervision</li> <li>Supervision of at least 3 BB projects</li> </ul>	One year
	Nominated	<ul style="list-style-type: none"> <li>Graduate of BB and MBB courses</li> <li>Supervision of less than 3 BB projects</li> </ul>		Permanent
BB	Full-time	<ul style="list-style-type: none"> <li>Full-time project leader</li> <li>Graduate of BB course</li> <li>Completion of 2 BB projects</li> </ul>	<ul style="list-style-type: none"> <li>Full-time project leader</li> <li>Completion of 2 projects</li> <li>Supervision of at least 12 GB projects</li> </ul>	One year
	Certified	<ul style="list-style-type: none"> <li>Part-time project leader</li> <li>Graduate of BB course</li> <li>Completion of 2 BB projects</li> </ul>	<ul style="list-style-type: none"> <li>Part-time project leader</li> <li>Completion of 1 project</li> <li>Supervision of at least 4 GB projects</li> </ul>	One year
	Nominated	<ul style="list-style-type: none"> <li>Graduate of BB course</li> <li>Completion of less than 2 BB projects</li> </ul>		Permanent
GB	No class	<ul style="list-style-type: none"> <li>Graduate of GB course</li> <li>Completion of 1 project</li> </ul>	<ul style="list-style-type: none"> <li>Completion of 1 project</li> </ul>	One year
WB	No class	<ul style="list-style-type: none"> <li>Graduate of WB course</li> </ul>		Permanent

**(5) Major results of Six Sigma**

In the first half of 2000, 68 projects were completed, and their savings were about \$18 million, and about \$100,000 was awarded to the project teams by the incentive system. The total sales for 1998, 1999 and 2000 were \$3.86 billion, \$4.25 billion, \$5.23 billion (estimated), respectively. The excellent Six Sigma programs contributed to the sharp increases. The pre-tax profits for these three years were \$51.7 million, \$166.7 million, and \$600 million, respectively, exhibiting dramatic yearly increases.

The quality cost in 1999 was \$0.38 billion, or 11.3% of total sales. However, due to intensive project activities to reduce the quality cost, the quality cost for 2000 was estimated at \$0.30 billion, or roughly 5.6% of the total sales. This remarkable gain in sales and profit together with reduction of quality costs attest to the positive effects of Six Sigma projects.

### **3.5 Digital Appliance Company of LG Electronics: Success Story with Six Sigma**

#### **(1) Introduction**

The Digital Appliance company of LG Electronics (LGE-DA) is another company which received the first national Six Sigma quality prize in 2000. LGE was founded in 1958 under the name of Goldstar, and later became LGE in 1995. LGE consists of three companies: Digital Appliance, Digital Media, and Digital Multimedia. LGE-DA received the first national Six Sigma quality award. The major products of LGE-DA are air conditioners, washing machines, vacuum cleaners, microwave ovens, air compressors, refrigerators and motors. As of 2000, the company had 4,800 employees with total sales of \$2.5 billion. LGE now has 30 different overseas subsidiaries in China, Turkey, England, Mexico, Hungary, India, Vietnam, Indonesia, and other countries.

#### **(2) Business innovation activity**

The business innovation activities of LGE-DA since 1990 are sketched roughly in Figure 3.5. In early 1990s, for business reasons the company concentrated on cooperation of capital and labor, since there were numerous labor strikes in the late 1980s. After they overcame the labor problems, the price reduction movement became the major business issue for competitiveness in the international market. In 1998, Korea was hit by the so-called “IMF crisis” and all business sectors were in bad shape. From 2000 onwards, the Korean economy began to revive. Although LGE-DA adopted the Six Sigma concept from

1996, only in 2000 did LGE-DA ardently employ Six Sigma to sharply upgrade its business performance and set its goal to be “The global top tier in appliance industries” by 2003.

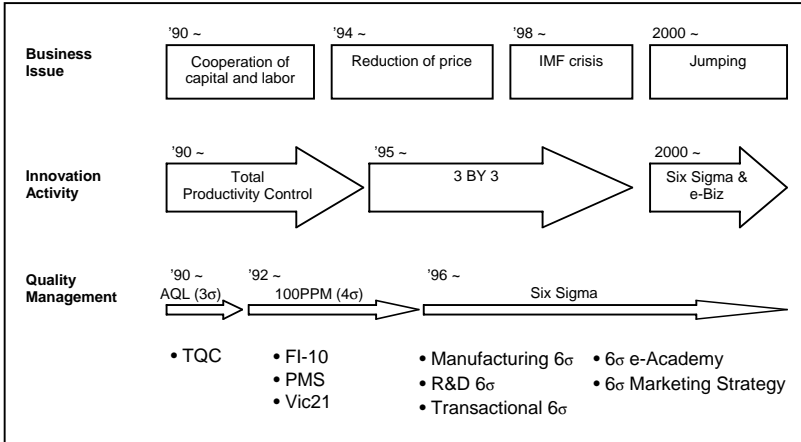

IMF: International Monetary Fund

3BY3: Movement of 3 times increase in productivity and profit in 3 years

AQL: Average Quality Level

100PPM: Quality movement to produce at most 100 defective items in one million items produced.

FI-10: Factory Innovation 10. This movement demands that the 10 most vital problems in the factory should be resolved through innovation.

PMS: Product Marketing Strategy

Vic21: Product development process using concurrent engineering

**Figure 3.5.** Business innovation activities

For innovation activities, LGE-DA adopted TPC which is based on TQC (total quality control). Since 1995, it has adopted “3BY3” movement in order to improve productivity and sales profit 3 times in 3 years. From 2000 Six Sigma and e-business strategies became the major innovation activities for this company. As far as quality management is concerned, the AQL was approximately at the  $3\sigma$  level until 1991. Owing to the 100PPM movement since 1992, the company became successful in enhancing its quality level to  $4\sigma$ . In 1996 it adopted Six Sigma, challenging itself to achieving the goal of

6σ quality level in a few years. The company established a 6σ e-Academy for training people, and adopted a 6σ marketing strategy as their major quality management concept.

### (3) Six Sigma roadmap

The Six Sigma quality initiative at LGE-DA means “total customer satisfaction” with the products and services it provides. In order to achieve total customer satisfaction, the company made the Six Sigma roadmap as shown in Figure 3.6. Six Sigma is divided into three parts: manufacturing 6σ, R&D 6σ and transactional 6σ. LGE-DA adopted “manufacturing 6σ” first in 1996, and then “R&D 6σ” in 1997. “Transactional 6σ” was attempted from 1999.

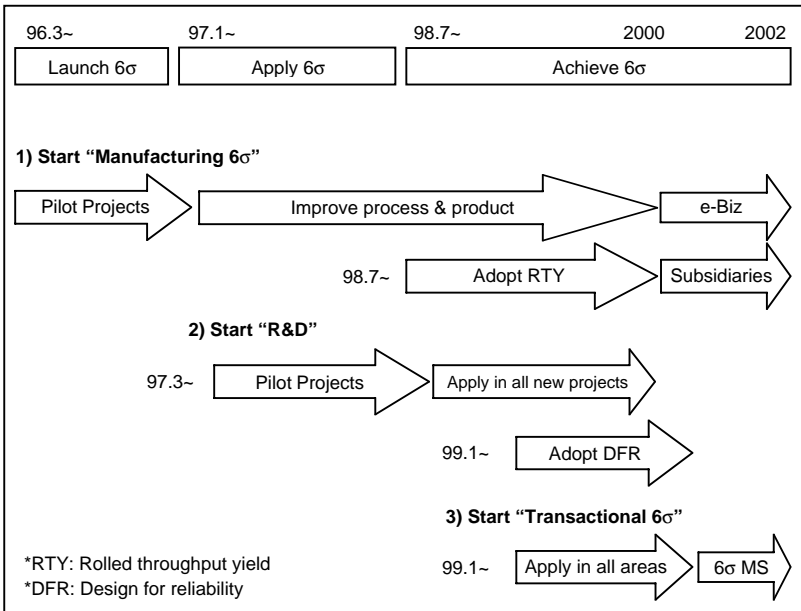

**Figure 3.6.** Six Sigma roadmap

Improving RTY became the major projects in manufacturing areas, and then the know-how of RTY improvement was transferred to all subsidiaries. For R&D areas, DFR became the major concern, and the improvement in reliability of prod-

ucts became the key goal for the R&D parts. For transactional areas,  $6\sigma$  marketing strategy was adopted to improve market share through total customer satisfaction.

**(4) Six Sigma infrastructure**

The Six Sigma infrastructure of LGE-DA consists of six elements as shown in Table 3.4. These six elements are the leading forces defining Six Sigma for this company.

**Table 3.4.** Contents of Six Sigma infrastructure

<b>Infrastructure</b>	<b>Contents</b>
Belt certification system	<ul style="list-style-type: none"> <li>• Six Sigma manpower training and reward system</li> <li>• Three belts of GB, BB, MBB</li> </ul>
TDR team	<ul style="list-style-type: none"> <li>• TDR (tear-down and redesign) teams are Six Sigma project teams</li> <li>• 40% of office employees are involved in TDR teams.</li> </ul>
PTS	<ul style="list-style-type: none"> <li>• PTS (project tracking system) helps to control projects and to share the results.</li> </ul>
On-site top meeting	<ul style="list-style-type: none"> <li>• Top-level manager conducts on-site visits twice a month, and checks the progress of Six Sigma.</li> </ul>
Champion review	<ul style="list-style-type: none"> <li>• Top-level manager conducts on-site visits twice a month, and checks the progress of Six Sigma.</li> </ul>
Lot evaluation system	<ul style="list-style-type: none"> <li>• ILO QA (Input QC, Line QC, Output QC Quality Assurance) system works for lot quality control which is focused on CTQs.</li> </ul>

**(5) Six Sigma current status**

As shown in Table 3.5, the average quality level of key products in this company was estimated at  $5.7\sigma$  at the end of 2002. The number of certified MBBs, BBs and GBs was estimated to be 50, 1,000 and 1,000, respectively, at the end of 2002. Considering that the total number of employees is only about 4,800, these numbers are quite substantial.

**Table 3.5.** 6 $\sigma$  Status and Goal

Year		2000	2001	2002 (estimated)
Average $\sigma$ level		5.4	5.6	5.7
Belts	MBB	33	38	50
	BB	196	539	1,000
	GB	965	1,031	1,000
Completed projects		1,312	1,403	1,400

The total number of completed projects was 1,312, 1,403, and 1,400 for the years of 2000, 2001, and 2002, respectively. Roughly 40% of all BBs were full-time project leaders. The BBs are the core force for completing the projects. During the month of July, 2002, the completed projects were as follows. These titles reveal the types of projects that are tackled usually by the project teams at LGE-DA.

R&D projects:

1. Side-by-side refrigerator project
2. Turbo-drum washing machine project
3. Light wave oven project
4. Air conditioner WHISEN project

Manufacturing projects:

1. Air conditioner heat exchanger loss reduction project
2. Washing machine clutch quality improvement project
3. Refrigerator RTY (rolled throughput yield) improvement project
4. Air conditioner compressor productivity improvement project

Transactional projects:

1. Inventory reduction project
2. Quick response project

**(6) Six Sigma focus**

Six Sigma at LGE-DA is customer-focused, process-driven and practically implemented through on-going Six Sigma projects. Six Sigma in this company means the following three things:

1. Statistical process evaluation: They measure defect rates in all processes and use s quality level in measuring process capability.
2. Business strategy: They gain a competitive edge in quality, cost and customer satisfaction.
3. Management philosophy: They work smarter based on data analysis and teamwork.

For customer satisfaction, they analyze the “Needs” of the customers. The major elements of these needs are delivery, price and quality. In order to solve the “Needs,” they should “Do” work smartly. The major elements of “Do” relate to cycle time, cost and defects which are mostly process driven. Figure 3.7 shows this concept clearly. To connect and solve the issues on the “Do” and “Needs” interaction, project team activities are necessary. The important project focus is as shown in Figure 3.7

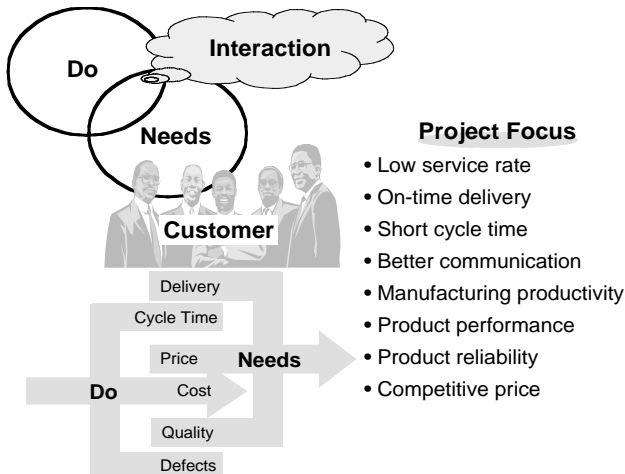

**Figure 3.7.** Six Sigma focus

**(7) Major results of Six Sigma**

Many performance indices have improved since the introduction of Six Sigma in this company. Based on the “Explanation book of the current status of Six Sigma” published in 2000, the following statistics were obtained with regard to Six Sigma results.

**Table 3.6.** Major results of Six Sigma

<b>Year</b>	<b>1997</b>	<b>1998</b>	<b>1999</b>	<b>2000</b>
Quality level of major CTQs	3.5	4.5	5.2	5.4
Completed projects	109	682	1,124	1,312
Profit gains by projects (million \$)	—	19.9	53.9	66.4
Manpower productivity: sales/person (\$1,000)	275	327	327	510
Failure cost rate: (failure cost) ÷ (total sales)	2.4%	1.6%	1.0%	0.8%

## 4. Basic QC and Six Sigma Tools

---

### 4.1 The 7 QC Tools

The Seven Quality Control tools (7QC tools) are graphical and statistical tools which are most often used in QC for continuous improvement. Since they are so widely utilized by almost every level of the company, they have been nicknamed the Magnificent Seven. They are applicable to improvements in all dimensions of the process performance triangle: variation of quality, cycle time and yield of productivity.

Each one of the 7QC tools had been used separately before 1960. However, in the early 1960s, they were gathered together by a small group of Japanese scientists lead by Kaoru Ishikawa, with the aim of providing the QC Circles with effective and easy-to-use tools. They are, in alphabetical order, cause-and-effect diagram, check sheet, control chart, histogram, Pareto chart, scatter diagram and stratification. In Six Sigma, they are extensively used in all phases of the improvement methodology – define, measure, analyze, improve and control.

#### *(1) Cause-and-effect diagram*

An effective tool as part of a problem-solving process is the cause-and-effect diagram, also known as the Ishikawa diagram (after its originator) or fishbone diagram. This technique is useful to trigger ideas and promote a balanced approach in group brainstorming sessions where individuals list the perceived sources (causes) with respect to outcomes (effect). As shown in Figure 4.1, the effect is written in a rectangle on the right-hand side, and the causes are listed on the left-hand side. They are connected with arrows to show the cause-and-effect relationship.

When constructing a cause-and-effect diagram, it is often appropriate to consider six main causes that can contribute to an outcome response (effect): so-called 5M1E (man, machine, material, method, measurement, and environment).

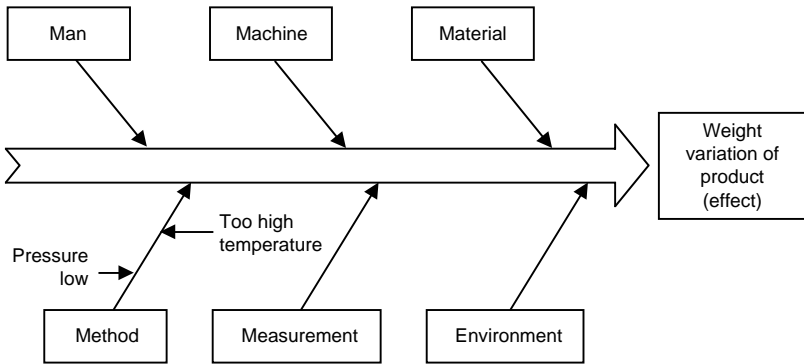

**Figure 4.1.** An example of a cause-and-effect diagram

When preparing a cause-and-effect diagram, the first step is to agree on the specific wording of the effect and then to identify the main causes that can possibly produce the effect. The main causes can often be identified as any of 5M1E, which helps us to get started, but these are by no means exhaustive. Using brainstorming techniques, each main cause is analyzed. The aim is to refine the list of causes in greater detail until the root causes of that particular main cause are established. The same procedure is then followed for each of the other main causes. In Figure 4.1, the method is a main cause, the pressure and the temperature are the causes, and “the pressure is low” and “the temperature is too high” are the root causes.

## (2) Check sheet

The check sheet is used for the specific data collection of any desired characteristics of a process or product that is to be improved. It is frequently used in the measure phase of the Six Sigma improvement methodology, DMAIC. For practical purposes, the check sheet is commonly formatted as a table. It is important that the check sheet is kept simple and that its design is aligned to the characteristics that are measured. Consideration should be given as to who should gather the data and what measurement intervals to apply. For example, Figure 4.2 shows a check sheet for defect items in an assembly process of automobile ratios.

Data gathered by S.H. Park

Defect item	Date					Sum
	Aug. 10	Aug. 11	Aug. 12	Aug. 13	Aug. 14	
Soldering defect	//	/	///		///	11
Joint defect	//	//		/	///	8
Lamp defect		/	//	//	/	6
Scratch defect	///	///	///	///	//	24
Miscellaneous	/	//	///	/	//	9
Sum	9	12	11	12	13	58

Figure 4.2. Check sheet for defect items

### (3) Control chart

#### (a) Introduction

The control chart is a very important tool in the “analyze, improve and control” phases of the Six Sigma improvement methodology. In the “analyze” phase, control charts are applied to judge if the process is predictable; in the “improve” phase, to identify evidence of special causes of variation so that they can be acted on; in the “control” phase, to verify that the performance of the process is under control.

The original concept of the control chart was proposed by Walter A. Shewhart in 1924 and the tool has been used extensively in industry since the Second World War, especially in Japan and the USA after about 1980. Control charts offer the study of variation and its source. They can give process monitoring and control, and can also give direction for improvements. They can separate special from common cause issues of a process. They can give early identification of special causes so that there can be timely resolution before many poor quality products are produced.

Shewhart control charts track processes by plotting data over time in the form shown in Figure 4.3. This chart can track either variables or attribute process parameters. The

types of variable charts are process mean ( $\bar{x}$ ), range (R), standard deviation (s), individual value (x) and moving range (Rs). The attribute types are fraction nonconforming (p), number of nonconforming items (np), number of nonconformities (c), and nonconformities per unit (u).



**Figure 4.3.** Shewhart control chart format

The typical control limits are plus and minus 3 standard deviations limits using about 20-30 data points. When a point falls outside these limits, the process is said to be out of control. When a point falls inside these limits, the process is said to be under control.

There are various types of control charts, depending on the nature and quantity of the characteristics we want to supervise. The following control charts are the most often used ones depending on whether the data are continuous or discrete. These charts are called Shewhart control charts. Note that for continuous data, the two types of chart are simultaneously used in the same way as a single control chart.

For continuous data (variables):

$\bar{x} - R$  (average and range) chart

$\bar{x} - s$  (average and standard deviation) chart

$\bar{x} - Rs$  (individual observation and moving range) chart

For discrete data (attributes):

- $p$  (fraction of nonconforming items) chart
- $np$  (number of nonconforming items) chart
- $c$  (number of defects) chart
- $u$  (number of defects per unit) chart

Besides these charts, the following new charts for continuous data have been suggested and studied. For good references for control charts, see

- CUSUM (cumulative sum) chart
- MA (moving average) chart
- GMA (geometric moving average) chart
- EWMA (exponentially weighted moving average) chart

(b) How are control charts constructed?

A detailed generic sequence for construction of control charts can be developed, which can be useful when working with control charts in practice.

### **Step 1. Select the characteristic and type of control chart**

First, the decision must be made regarding the characteristic (effect) of the process or product that is to be checked or supervised for predictability in performance. Then the proper type of control chart can be selected.

### **Step 2. Determine the sample size and sampling interval**

Control charts are, in most cases, based on samples of a constant number of observations,  $n$ . For continuous data, it is common to use two to six observations. However, there are also charts for subgroup sizes of one,  $x$  (individual observation) chart and  $R_s$  (moving range) chart. For discrete data,  $n$  could be as large as 100 or 200.

### **Step 3. Calculate the control lines and center line**

All control charts have control limits, UCL and LCL, showing when the process is affected by special cause variation. A CL is drawn between the control limits. The distance from CL to UCL/LCL is 3 standard deviations of the characteristic.

For example, for n individual observations,

$$x_1, x_2, x_3 \dots x_n$$

the following formulae apply to the calculation of CL, UCL and LCL for the  $\bar{x}$  (average) chart.

$$CL = \bar{x} = \sum x_i / n$$

$$UCL = \bar{x} + 3 \text{ (standard deviation of } x)$$

$$= \bar{x} + 3 \text{ (estimated } \sigma) / \sqrt{n}$$

$$= \bar{x} + 3(\bar{R} / d_2) / \sqrt{n}$$

$$= \bar{x} + A_2 \times \bar{R} \text{ where } A_2 = 3 / (d_2 \times \sqrt{n}) \tag{4.1}$$

$$LCL = \bar{x} - A_2 \times \bar{R}$$

Here,  $A_2$  and  $d_2$  are the frequently used constants for control charts, which can be found in Appendix A-4. Table 4.1 contains CL, UCL and LCL for the respective control charts.

**Table 4.1.** CL, UCL and LCL for each control chart

Continuous characteristics				
Sample	Average	Range	Standard deviation	Individual value
1	$\bar{x}_1$	$R_1$	$s_1$	$x_1$
2	$\bar{x}_2$	$R_2$	$s_2$	$x_2$
...	...	...	...	...
K	$\bar{x}_k$	$R_k$	$s_k$	$x_k$
Average & CL	$\bar{\bar{x}}$	$\bar{R}$	$\bar{s}$	$\bar{x}$
UCL/LCL	$\bar{\bar{x}} \pm A_2 \bar{R}$	$\bar{R} \pm D_3 \bar{R}$	$\bar{s} \pm B_3 \bar{s}$	$\bar{x} \pm 2.66 \bar{R} s$
Discrete characteristics				
Sample	Fraction of nonconformities	Number of nonconformities	Fraction of defects	Fraction of defects per unit
1	$p_1$	$np_1$	$c_1$	$u_1$
2	$p_2$	$np_2$	$c_2$	$u_2$
...	...	...	...	...
K	$p_k$	$np_k$	$c_k$	$u_k$
Average & CL	$\bar{p}$	$n\bar{p}$	$\bar{c}$	$\bar{u}$
UCL/LCL	$\bar{p} \pm 3\sqrt{\bar{p}(1-\bar{p})/n}$	$n\bar{p} \pm 3\sqrt{n\bar{p}(1-\bar{p})}$	$\bar{c} \pm 3\sqrt{\bar{c}}$	$\bar{u} \pm 3\sqrt{\bar{u}/n}$

#### **Step 4. Draw the control chart and check for special causes**

The control chart can now be drawn, with CL, UCL and LCL. The samples used for calculating the control limits are then plotted on the chart to determine if the samples used to calculate the control limits embody any special causes of variation. Special causes exist if any of the following alarm rules apply:

- A single point falls outside the  $\pm 3\sigma$  control limits.
- Two out of three consecutive points fall outside the  $\pm 2\sigma$  limits.
- Seven or more consecutive points fall to one side of the center line.
- A run of eight or more consecutive points is up (in increasing trend), or down (in decreasing trend).
- At least 10 out of 11 consecutive points are on one side of the center line.
- At least eight consecutive points make a cycle movement, which means if a point is on one side of the center line, and the next point is on the other side of the center line.

#### **(4) Histogram**

It is meaningful to present data in a form that visually illustrates the frequency of occurrence of values. In the analysis phase of the Six Sigma improvement methodology, histograms are commonly applied to learn about the distribution of the data within the results Ys and the causes Xs collected in the measure phase and they are also used to obtain an understanding of the potential for improvements.

To create a histogram when the response only “takes on” certain discrete values, a tally is simply made each time a discrete value occurs. After a number of responses are taken, the tally for the grouping of occurrences can then be plotted in histogram form. For example, Figure 4.3 shows a histogram of 200 rolls of two dice, where, for instance, the sum of the dice was two for eight of these rolls. However, when making a histogram of response data that are continuous, the data

need to be placed into classes or groups. The area of each bar in the histogram is made proportional to the number of observations within each data value or interval. The histogram shows both the process variation and the type of distribution that the collected data entails.

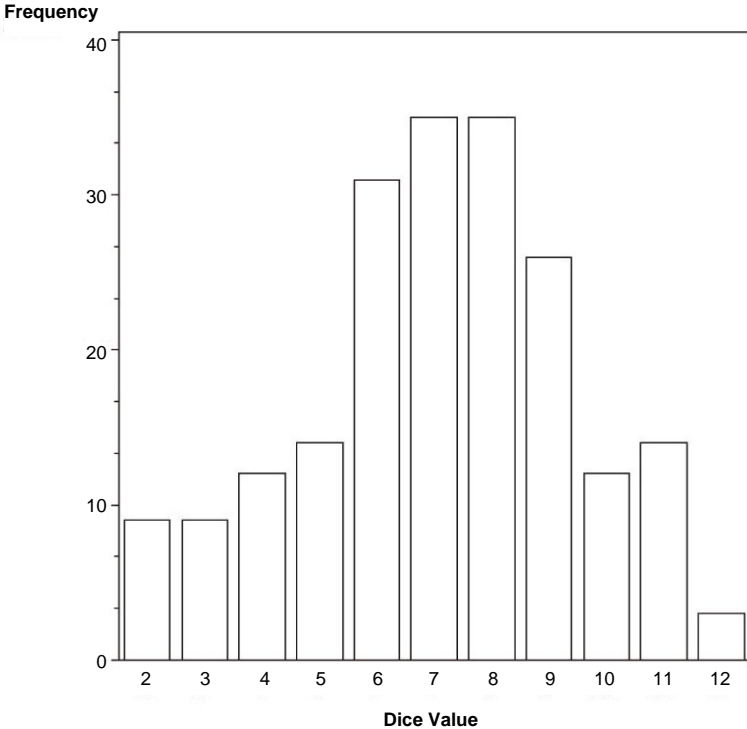

Figure 4.3. Histogram of 200 rolls of two dice

(5) *Pareto chart*

The Pareto chart was introduced in the 1940s by Joseph M. Juran, who named it after the Italian economist and statistician Vilfredo Pareto, 1848–1923. It is applied to distinguish the “vital few from the trivial many” as Juran formulated the purpose of the Pareto chart. It is closely related to the so-called 80/20 rule – “80% of the problems stem from 20% of

the causes,” or in Six Sigma terms “80% of the poor values in Y stem from 20% of the Xs.”

In the Six Sigma improvement methodology, the Pareto chart has two primary applications. One is for selecting appropriate improvement projects in the define phase. Here it offers a very objective basis for selection, based on, for example, frequency of occurrence, cost saving and improvement potential in process performance.

The other primary application is in the analyze phase for identifying the vital few causes (Xs) that will constitute the greatest improvement in Y if appropriate measures are taken.

A procedure to construct a Pareto chart is as follows:

- 1) Define the problem and process characteristics to use in the diagram.
- 2) Define the period of time for the diagram – for example, weekly, daily, or shift. Quality improvements over time can later be made from the information determined within this step.
- 3) Obtain the total number of times each characteristic occurred.
- 4) Rank the characteristics according to the totals from step 3.
- 5) Plot the number of occurrences of each characteristic in descending order in a bar graph along with a cumulative percentage overlay.
- 6) Trivial columns can be lumped under one column designation; however, care must be exercised not to omit small but important items.

Table 4.2 shows a summary table in which a total of 50 claims during the first month of 2002 are classified into six different reasons. Figure 4.4 is the Pareto chart of the data in Table 4.2.

**Table 4.2.** Summary of claim data

Claim reason	Number of data	%	Cumulative frequency	Cumulative (%)
A	23	46	23	46
B	10	20	33	66
C	7	14	40	80
D	3	6	43	86
E	2	4	45	90
All others	5	10	50	100

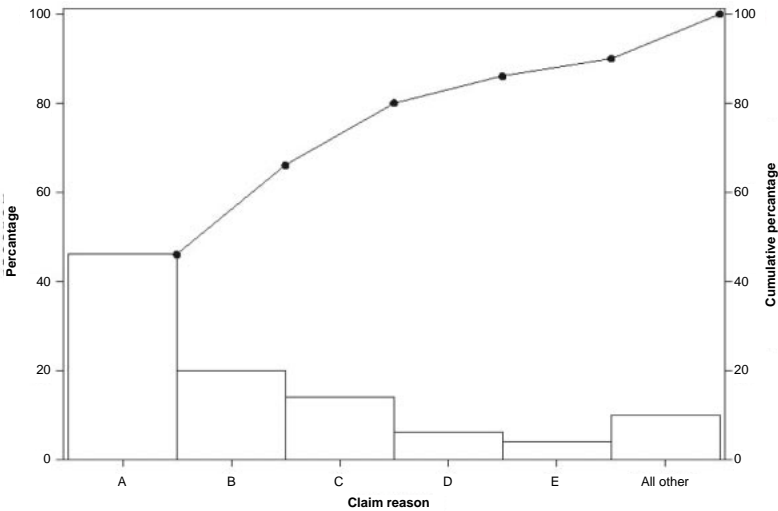

**Figure 4.4.** Pareto chart of 50 claim data

**(6) Scatter diagram**

The scatter plot is a useful way to discover the relationship between two factors, X and Y, i.e., the correlation. An important feature of the scatter plot is its visualization of the correlation pattern, through which the relationship can be determined. In the improve phase of the Six Sigma improvement methodology, one often searches the collected data for Xs that have a special influence on Y. Knowing the existence of such relationships, it is possible to identify input variables that

cause special variation of the result variable. It can then be determined how to set the input variables, if they are controllable, so that the process is improved. When several Xs may influence the values of Y, one scatter plot should be drawn for each combination of the Xs and Y.

When constructing the scatter diagram, it is common to place the input variable, X, on the X-axis and the result variable, Y, on the Y-axis. The two variables can now be plotted against each other and a scatter of plotted points appears. This gives us a basic understanding of the relationship between X and Y, and provides us with a basis for improvement.

Table 4.3 shows a set of data depicting the relationship between the process temperature (X) and the length of the plastic product (Y) made in the process. Figure 4.5 shows a scatter diagram of the data in Table 4.3.

**Table 4.3.** Data for temperature (X) and product length (Y) in a plastic-making process

X (°C)	Y (mm)	X (°C)	Y (mm)
131	22.99	129	23.01
135	23.36	135	23.42
136	23.62	134	23.16
130	22.86	126	22.87
132	23.16	133	23.62
133	23.28	134	23.63
132	22.89	130	23.01
131	23.00	131	23.12
128	23.08	136	23.50
134	23.64	133	22.75

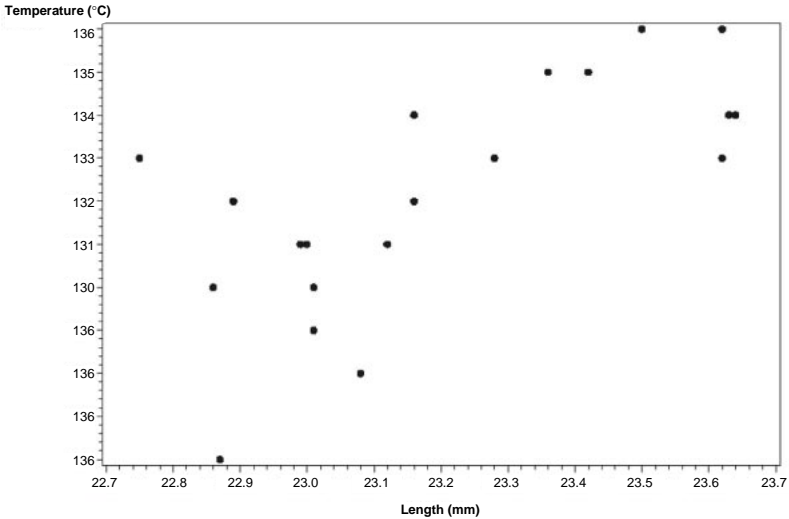

**Figure 4.5.** Scatter diagram of data in Table 4.3

**(7) Stratification**

Stratification is a tool used to split collected data into sub-groups in order to determine if any of them contain special cause variation. Hence, data from different sources in a process can be separated and analyzed individually. Stratification is mainly used in the analyze phase to stratify data in the search for special cause variation in the Six Sigma improvement methodology.

The most important decision in using stratification is to determine the criteria by which to stratify. Examples can be machines, material, suppliers, shifts, day and night, age groups and so on. It is common to stratify into two groups. If the number of observations is large enough, more detailed stratification is also possible.

**4.2 Process Flowchart and Process Mapping**

**(1) Process flowchart**

For quality systems it is advantageous to represent system structure and relationships using flowcharts. A flowchart pro-

vides a picture of the steps that are needed to understand a process. Flowcharts are widely used in industry and have become a key tool in the development of information systems, quality management systems, and employee handbooks. The main value of the flowchart resides in the identification and mapping of activities in processes, so that the main flows of products and information are visualized and made known to everyone.

In every Six Sigma improvement project, understanding the process is essential. The flowchart is therefore often used in the measure phase. It is also used in the analyze phase for identifying improvement potential compared to similar processes and in the control phase to institutionalize the changes made to the process.

Flowcharts can vary tremendously in terms of complexity, ranging from the most simple to very advanced charts. When improving variation, a very simple flowchart is often applied in the measure phase to map the Xs (input variables) and Y (result variable) of the process or product to be improved. The input variables are either control factors or noise factors, and the flowchart provides a good tool for visualizing them, as shown in Figure 4.6. This figure is related to an improvement project from ABB in Finland where the flowchart was used to map the control and noise factors in the input. This chart was later used in the improvement phase for running a factorial experiment on the control factors, making possible a considerable reduction of DPMO in the process and a cost savings of \$168,000.

The drawing of flowcharts has become fairly standardized, with a dedicated international standard, ISO 5807, titled “Information processing – Documentation symbols and charts and system resources charts.” The standard gives a good overview of symbols used in flowcharts, as seen in Figure 4.7. The symbols are commonly available in software for drawing flowcharts, for example PowerPoint from Microsoft. Figure 4.8 exemplifies the form of a process flowchart.

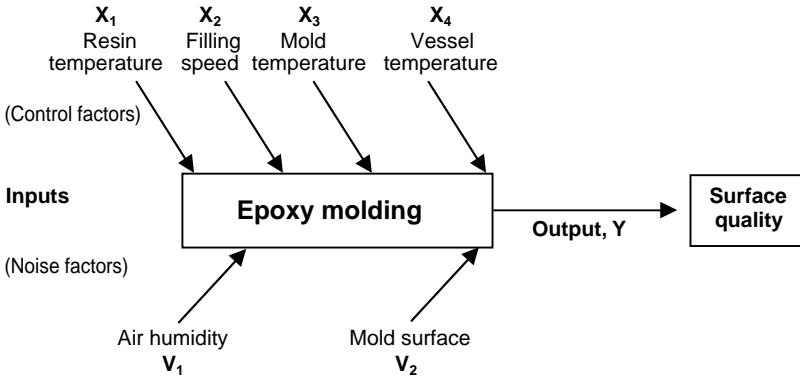

Figure 4.6. Flowchart for input and output variables

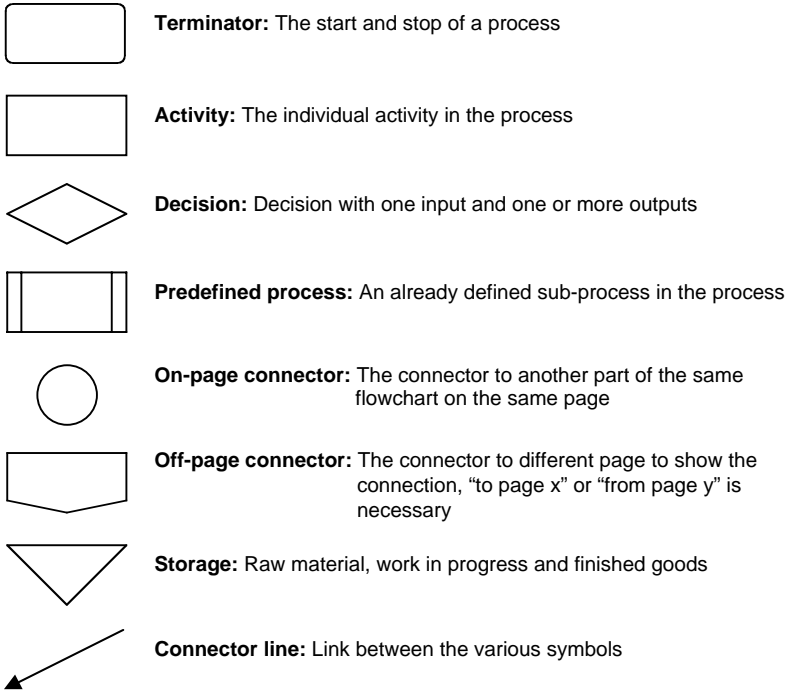
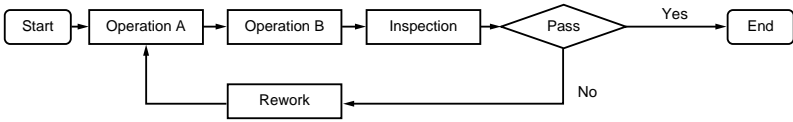

Figure 4.7. Most commonly used symbols in flowcharts



**Figure 4.8.** Process flowchart

**(2) Process mapping**

An alternative (or supplement) to a detailed process flowchart is a high-level process map that shows only a few major process steps as activity symbols. For each of these symbols key process input variables (KPIVs) to the activity are listed on one side of the symbol, while key process output variables (KPOVs) to the activity are listed on the other side of the symbol. Note that a KPIV can be a CTQ<sub>x</sub>, and a KPOV can be a CTQ<sub>y</sub>.

**4.3 Quality Function Deployment (QFD)**

**(1) Four phases of QFD**

Quality Function Deployment (QFD) is a structured technique to ensure that customer requirements are built into the design of products and processes. In Six Sigma, QFD is mainly applied in improvement projects on the design of products and processes. Hence, QFD is perhaps the most important tool for DFSS (design for Six Sigma). QFD enables the translation of customer requirements into product and process characteristics including target value. The tool is also applied in Six Sigma to identify the critical-to-customer characteristics which should be monitored and included in the measurement system.

QFD was developed in Japan during the late 1960s by Shigeru Mizuno (1910–1989) and Yoji Akao (1928–). It was first applied at the Kobe shipyard of Mitsubishi Heavy Industry in 1972, with the Japanese car industry following suit some years later. In the West, the car industry first applied the tool in the mid 1980s. Since then, it has enjoyed a wide dis-

persal across industries in a number of countries.

Although QFD is primarily used to map and systematically transform customer requirements, this is not its only use. Other possible applications concern the translation of market price into costs of products and processes, and company strategies into goals for departments and work areas.

Basically, QFD can be divided into four phases of transformation as shown in Figure 4.9. These four phases have been applied extensively, especially in the automobile industry.

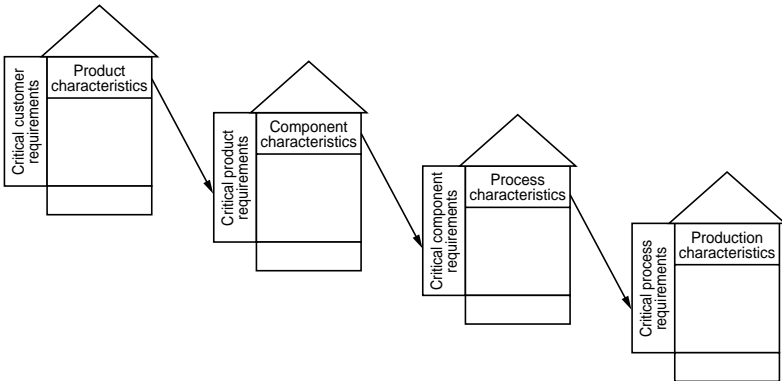

**Figure 4.9.** Four phases of transformation in QFD

**Phase 1:** Market analysis to establish knowledge about current customer requirements which are considered as critical for their satisfaction with the product, competitors' rating for the same requirements and the translation into product characteristics.

**Phase 2:** Translation of critical product characteristics into component characteristics, i.e., the product's parts.

**Phase 3:** Translation of critical component characteristics into process characteristics.

**Phase 4:** Translation of critical process characteristics into production characteristics, i.e., instructions and measurements.

The four phases embody five standard units of analysis always transformed in the following order: customer requirements, product characteristics, component characteristics,

process characteristics, and production characteristics. The level of detail hence increases from general customer requirements to detailed production characteristics. At each phase the main focus is on the transformation from one of these units of analysis, the so-called “Whats,” and to the other more detailed unit of analysis, the so-called “Hows.” At each of the four phases in Figure 4.9, the left-hand requirements are “Whats,” and the upper right hand characteristics are “Hows.”

A basic matrix, possessing some resemblances to a house, embodying 11 elements (rooms), is used to document the results of each of the four phases of transformation in QFD as shown in Figure 4.10. Often this matrix is called the house of quality. The numbers in parentheses indicate the sequence in which the elements of the matrix are completed.

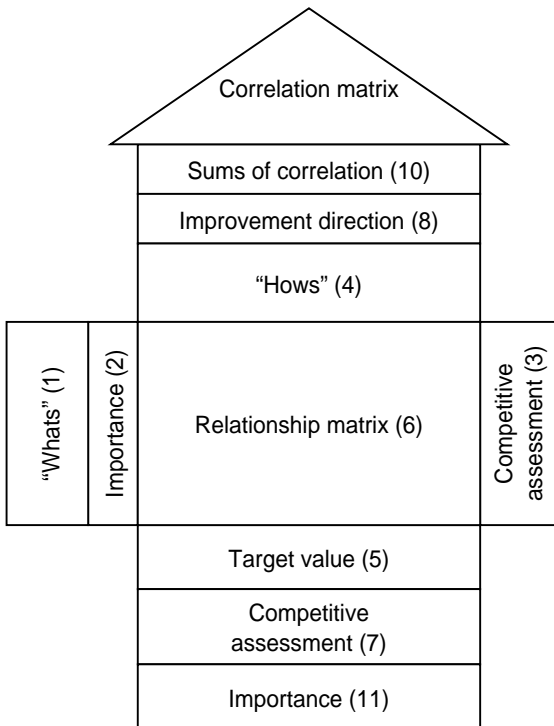

**Figure 4.10.** The house of quality with the 11 major elements

## (2) *Eleven elements of house of quality*

Of the 11 elements in the basic matrix shown in Figure 4.10, the first three are concerned with characteristics of the “Whats,” whereas the remaining eight are concerned with characteristics of the “Hows.” In this house of quality, identifying the critical “Hows” which constitute the main result of each matrix is the essential task. In the following, a generic description of the eleven elements is given.

### 1) *The “Whats”*

The starting point is that the “Whats” are identified and included in the matrix. If it is the first phase of transformation, customer requirements will be the “Whats.” Customer requirements are given directly by the customers, which is sometimes called VOC (voice of customers).

### 2) *Relative importance*

In the first phase of transformation the customer is also asked to attach relative importance, for example on a scale from “1” = least to “5” = most, to each of the requirements they have stated. This holds similarly for the other phases. This importance is often denoted by  $R_{imp}$ .

### 3) *Competitive assessment*

A comparison of how well competitors and one’s own company meet the individual “Whats” can then be made. If the “Whats” are customer requirements, it is common that customers give input to this comparison. For the three other “Whats” – product characteristics, component characteristics and process characteristics – the comparison is typically carried out by the team applying QFD.

One way to do the comparison is to evaluate competitors,  $E_{com}$ , and one’s own company,  $E_{own}$ , on, for example, a scale from “1” = very poor to “5” = very good. Both the ranking of competitors and one’s own company can then be weighted with relative importance,  $R_{imp}$ , to obtain a better understanding of the significance of differences in score for the individual

“What.” Thus the weighted evaluation of each “What” for competitors and one’s own company is obtained by

$$E_{w.com} = E_{com} \times R_{imp}$$

$$E_{w.own} = E_{own} \times R_{imp}$$

#### 4) *The “Hows”*

For every “What,” several corresponding “Hows” should be identified and described. This is a core part of QFD and needs considerable attention. For all four phases, the task is conducted by the in-house team applying the tool. Customers will rarely be able to participate in this transition as they do not have enough technical knowledge of the processes and products.

#### 5) *Target value*

Target values are then set for each of the identified “Hows.” A target value is a quantified goal value, i.e., the nominal value for the distribution. It forms the basis for decisions to be made on the need for improvements.

#### 6) *Relationship matrix*

Each “What” is then related to the “Hows.” Each relationship is denoted by  $W_{ij}$ , where  $i$  is row number and  $j$  is column number in the matrix. A commonly accepted scale for indicating relationships is to use 9, 3, and 1, where

9 = strong relation

3 = medium relation

1 = poor relation

The relationship matrix is clearly very important as it provides the links between the “Whats” and the “Hows.”

#### 7) *Competitive assessment*

Comparison with competitors for each characteristic of the “Hows” can be made to determine how they are performing. A simple way to rank competitors,  $A_{com}$ , and one’s own company,  $A_{own}$ , for example, is on a scale from “1” = very poor to “5” = very good.



The relative importance of each “How,”  $I_{rel}$ , is derived by calculation. This is done by first computing the absolute importance of each of the “Hows.”

$$I_{abs} = \sum R_{imp} \times W_{ij}$$

For example, in Figure 4.12, the absolute importance of the first “How,” Length, becomes

$$I_{abs} = 4 \times 9 + 3 \times 3 + 2 \times 1 + 1 \times 3 = 50$$

Very often this absolute importance of each “How” is recalculated into relative importance,  $I_{rel}$ . This is done by normalizing the absolute importance, for example, on a scale from 0 to 10. For example, in Figure 4.12, the relative importance of the first “How,” Length, is

$$I_{rel} = (50/81) \times 10 \times 6.2$$

The “Hows” with the largest values for relative importance,  $I_{rel}$ , represent critical characteristics. A Pareto chart is sometimes helpful to apply in this evaluation. A few critical “Hows” may be selected from this relative importance. In the selection of critical “Hows,” it can sometimes be useful to also include the competitor assessment,  $A_{com}$ , and the assessment of one’s own company,  $A_{com}$ . The current ability of a company regarding each of the “Hows” can then be multiplied by the relative importance,  $I_{rel}$ , and compared. Some analysts even include the relative difficulty of improving the various “Hows” and use this as a further point in the analysis of critical “Hows.”

### *(3) Ballpoint pen example*

Let us take an example of a ballpoint pen made of metal. Customers have a variety of requirements. The most important requirements, from the viewpoint of the customers, are brought into Phase 1 of the transformation as shown in Figure 4.12.

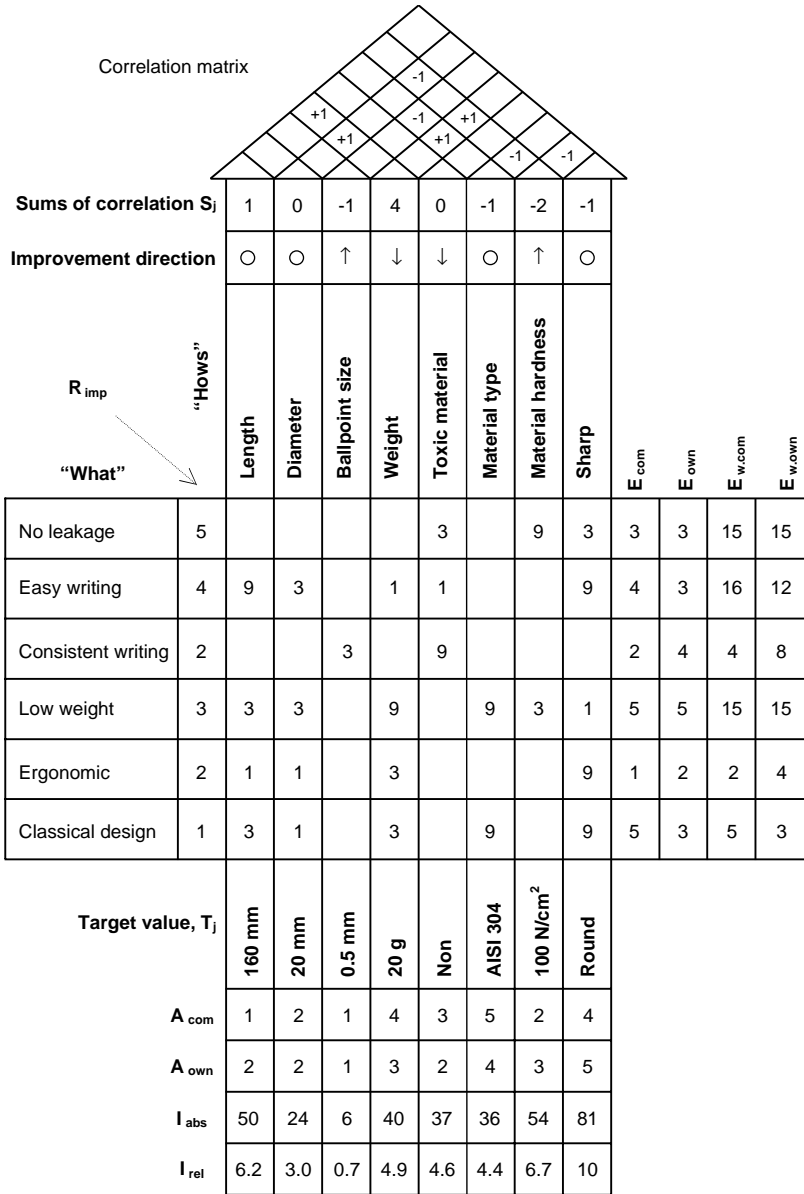

Figure 4.12. Phase 1 of transformation in the example of the ballpoint pen

From Figure 4.12, it is evident that the shape, material hardness, length, weight and toxic material are product characteristics (“Hows”) with high relative importance. It is important that these characteristics should be improved in order to fulfill customer requirements. The next three phases help identifying areas of improvement.

#### 4.4 Hypothesis Testing

##### *(1) Concept of hypothesis testing*

In industrial situations we frequently want to decide whether the parameters of a distribution have particular values or relationships. That is, we may wish to test a hypothesis that the mean or standard deviation of a distribution has a certain value or that the difference between two means is zero. Hypothesis testing procedures are used for these tests.

A statistical hypothesis is usually done by the following process.

- Set up a null hypothesis ( $H_0$ ) that describes the value or relationship being tested.
- Set up an alternative hypothesis ( $H_1$ ).
- Determine a test statistic, or rule, used to decide whether to reject the null hypothesis.
- a specified probability value, denoted as  $\sigma$ , that defines the maximum allowable probability that the null hypothesis will be rejected when it is true.
- Collect a sample of observations to be used for testing the hypothesis, and then find the value of the test statistic.
- Find the critical value of the test statistic using  $\sigma$  and a proper probability distribution table.
- Comparing the critical value and the value of the test statistic, decide whether the null hypothesis is rejected or not.

The result of the hypothesis test is a decision to either reject or not reject the null hypothesis; that is, the hypothesis is either

rejected or we reserve judgment on it. In practice, we may act as though the null hypothesis is accepted if it is not rejected. Since we do not know the truth, we can make one of the following two possible errors when running a hypothesis test:

1. We can reject a null hypothesis that is in fact true.
2. We can fail to reject a null hypothesis that is false.

The first error is called a type I error,  $\alpha$ , and the second is called a type II error,  $\beta$ . This relationship is shown in Figure 4.13. Hypothesis tests are designed to control the probabilities of making either of these errors; we do not know that the result is correct, but we can be assured that the probability of making an error is within acceptable limits. The probability of making a type I error is controlled by establishing a maximum allowable value of the probability, called the level of significance of the test, which is usually denoted by the letter  $\alpha$ .

		True state of nature	
		$H_0$	$H_1$
Conclusion made	$H_0$	Correct conclusion	Type II error ( $\beta$ )
	$H_1$	Type I error ( $\alpha$ )	Correct conclusion

**Figure 4.13.** Hypothesis testing error types

*(2) Example*

A manufacturer wishes to introduce a new product. In order to be profitable, the product should be successfully manufactured within a mean time of two hours. The manufacturer can evaluate manufacturability by testing the hypothesis that the mean time for manufacture is equal to or less than two hours. The item cannot be successfully manufactured if the mean time is greater than two hours, so the alternative hypothesis is that the mean time is greater than two. If we use  $\mu$  and  $\mu_0$  to note the mean time and the hypothesized mean value, respectively, we can set up the hypotheses:

$$H_0 : \mu \leq \mu_0 \quad \text{and} \quad H_1 : \mu > \mu_0,$$

where  $\mu_0 = 2$ . This type of hypothesis which has inequality signs is called a one-sided test. If there is an equality sign in the null hypothesis, it is called a two-sided test.

The statistic used to test the hypothesis depends on the type of hypothesis being tested. Statisticians have developed good, or even optimal, rules for many situations. For this example, it is intuitively appealing that if the average of an appropriate sample of manufacturing times is sufficiently larger than two, the test statistic used for this case is

$$T = \frac{\bar{x} - \mu_0}{s / \sqrt{n}}. \quad (4.2)$$

If this test statistic  $T$  is large enough, then we can reject  $H_0$ . How much large? Well, that depends on the allowable probability of making an error and the related probability distribution.

Let us assume that the allowable probability of making an error is 5%. Then the level of significance is  $\alpha = 0.05$ . In fact, a 5% level of significance is mostly used in practice. Then the critical value of the test can be found from the t-distribution, which is  $t(n - 1, \alpha)$ . Then the decision is that

we reject  $H_0$ , if  $T > t(n - 1, \alpha)$ .

Suppose the manufacturer has nine sample trials and obtains the following data.

Data (unit: hours): 2.2, 2.3, 2.0, 2.2, 2.3, 2.6, 2.4, 2.0, 1.8.

We can find that the sample mean time and the sample standard deviation are

$$\bar{x} = 2.2, \quad s = 0.24,$$

Then the test statistic becomes

$$T = \frac{\bar{x} - \mu_0}{s / \sqrt{n}} = \frac{2.2 - 2.0}{0.24 / \sqrt{9}}.$$

If we use a 5% level of significance, the critical value is  $t(n - 1, \alpha) = t(8, 0.05) = 1.860$ . Since  $T = 2.250 > 1.860$ ,  $H_0$  is rejected with 5% Type I errors, which means that the mean time is more than two hours with maximum 5% probability of making an error.

## 4.5 Correlation and Regression

### (1) Correlation analysis

The scatter diagram which was explained pictorially in Section 4.1 describes the relationship between two variables, say X and Y. It gives a simple illustration of how variable X can influence variable Y. A statistic that can describe the strength of a linear relationship between two variables is the sample correlation coefficient ( $r$ ). A correlation coefficient can take values between  $-1$  and  $+1$ . A value of  $-1$  indicates perfect negative correlation, while  $+1$  indicates perfect positive correlation. A zero indicates no correlation. The equation for the sample correlation coefficient of two variables is

$$r = \frac{\sum (x_i - \bar{x})(y_i - \bar{y})}{\sqrt{\sum (x_i - \bar{x})^2 \sum (y_i - \bar{y})^2}}, \quad (4.3)$$

where  $(x_i, y_i)_{i=1,2,\dots,n}$  are the coordinate pair of evaluated values.

It is important to plot the analyzed data. The coefficient  $r$  simply shows the straight-line relationship between  $x$  and  $y$ . Two data variables may show no linear correlation ( $r$  is nearly zero), but they may still have a quadratic or exponential functional relationship. Figure 4.14 shows four plots with various correlation characteristics.

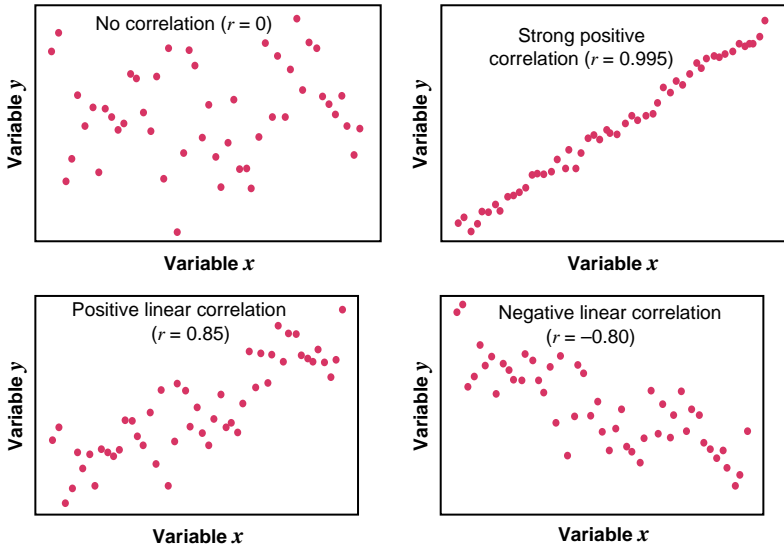

**Figure 4.14.** Correlation coefficients

The hypothesis test for the population correlation coefficient ( $\rho$ ) to equal zero is

$$H_0 : \rho = 0$$

$$H_1 : \rho \neq 0$$

which is a two-sided hypothesis test. The test statistic for this hypothesis test is

$$T = \frac{r\sqrt{n-2}}{\sqrt{1-r^2}}, \tag{4.4}$$

where  $H_0$  is rejected if the value of  $T$  is greater than  $t(n-2, \alpha/2)$ .

**(2) Example of correlation analysis**

In studying the decay of an aerosol spray, experimenters obtained the results shown in Table 4.4 (Box, Hunter and Hunter 1978), where  $x$  is the age in minutes of the aerosol and  $y$  is its observed dispersion at that time. Dispersion is measured

as the reciprocal of the number of particles in a unit volume. The  $n=9$  experiments were run in random order. The scatter diagram of these data is shown in Figure 4.15, which indicates that there is a strong correlation between the two variables.

**Table 4.4.** Aerosol data

Observed number	Order in which experiments were performed	Age ( $x$ )	Dispersion ( $y$ )
1	6	8	6.16
2	9	22	9.88
3	2	35	14.35
4	8	40	24.06
5	4	57	30.34
6	5	73	32.17
7	7	78	42.18
8	1	87	43.23
9	3	98	48.76

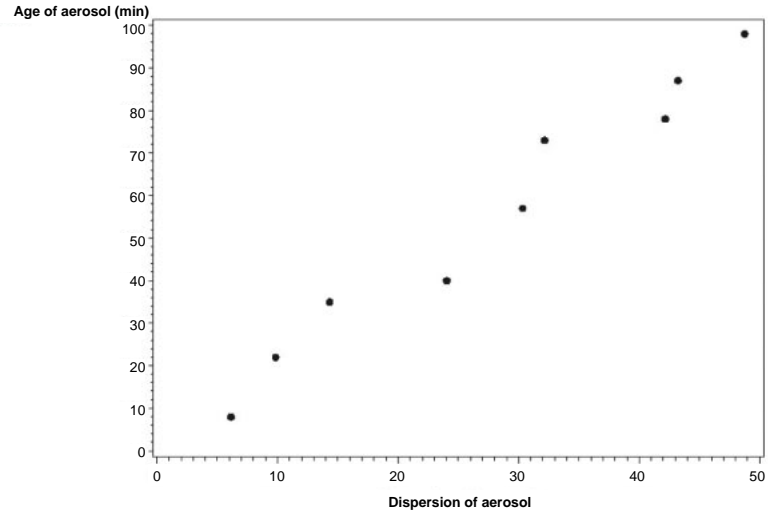

**Figure 4.15.** Scatter diagram of aerosol data

The sample correlation coefficient between  $x$  and  $y$  is determined to be

$$r = \frac{\sum(x_i - \bar{x})(y_i - \bar{y})}{\sqrt{\sum(x_i - \bar{x})^2 \sum(y_i - \bar{y})^2}} = 0.983.$$

Testing the null hypothesis that the correlation coefficient equals zero yields

$$T = \frac{r\sqrt{n-2}}{\sqrt{1-r^2}} = 14.229.$$

Hence, using a two-sided t-table at  $\alpha / 2$ , we can reject  $H_0$ , because the absolute value of T, 14.229, is greater than  $t(n - 2, \alpha / 2) = t(7, 0.025) = 2.365$  at the Type I error  $\alpha = 0.05$ .

### (3) Regression analysis

The simple linear regression model with a single regressor  $x$  takes the form

$$y = \beta_0 + \beta_1 x + \varepsilon, \quad (4.5)$$

where  $\beta_0$  is the intercept,  $\beta_1$  is the slope, and  $\varepsilon$  is the error term. Typically, none of the data points falls exactly on the regression model line. The error term makes up for these differences from other sources such as measurement errors, material variations in a manufacturing operation, and personnel. Errors are assumed to have a mean of zero and unknown variance  $\sigma^2$ , and they are not correlated.

When a linear regression model contains only one independent (regressor or predictor) variable, it is called simple linear regression. When a regression model contains more than one independent variable, it is called a multiple linear regression model. The multiple linear regression model with  $k$  independent variables is

$$y = \beta_0 + \beta_1 x_1 + \beta_2 x_2 + \dots + \beta_k x_k + \varepsilon. \quad (4.6)$$

If we have a data set such as,  $(x_i, y_i)$ ,  $i = 1, 2, \dots, n$ , the estimates of the regression coefficients of the simple linear regression model can be obtained through the method of least squares as follows:

$$\hat{\beta}_1 = \frac{\sum(x_i - \bar{x})(y_i - \bar{y})}{\sum(x_i - \bar{x})^2}, \quad (4.7)$$

$$\hat{\beta}_0 = \bar{y} - \hat{\beta}_1 \bar{x}.$$

Then the fitted regression line is

$$\hat{y} = \hat{\beta}_0 + \hat{\beta}_1 x,$$

which can be used for quality control of  $(x, y)$  and prediction of  $y$  at a given value of  $x$ .

It was found that there is a strong positive correlation between  $x$  and  $y$  in the aerosol data in Table 4.4. Let's find the simple regression equation for this data set. Since the estimated coefficients are from (4.7),

$$\hat{\beta}_1 = \frac{\sum(x_i - \bar{x})(y_i - \bar{y})}{\sum(x_i - \bar{x})^2} = 0.489,$$

$$\hat{\beta}_0 = \bar{y} - \hat{\beta}_1 \bar{x} = 0.839.$$

Hence, the fitted simple regression line is

$$\hat{y} = 0.839 + 0.489x.$$

When there is more than one independent variable, we should use the multiple linear regression model in (4.6). By the method of least squares, we can find the estimates of regression coefficients by the use of statistical packages such as SAS, SPSS, Minitab, S and so on. Then the fitted regression equation is

$$\hat{y} = \hat{\beta}_0 + \hat{\beta}_1 x_1 + \hat{\beta}_2 x_2 + \dots + \hat{\beta}_k x_k.$$

## 4.6 Design of Experiments (DOE)

### (1) *Framework of design of experiments*

Experiments are carried out by researchers or engineers in all fields of study to compare the effects of several conditions or to discover something new. If an experiment is to be performed most efficiently, then a scientific approach to planning it must be considered. The design of experiments (DOE) is the process of planning experiments so that appropriate data will be collected, the minimum number of experiments will be performed to acquire the necessary technical information, and suitable statistical methods will be used to analyze the collected data.

The statistical approach to experimental design is necessary if we wish to draw meaningful conclusions from the data. Thus, there are two aspects to any experimental design: the design of experiment and the statistical analysis of the collected data. They are closely related, since the method of statistical analysis depends on the design employed.

An outline of the recommended procedure for an experimental design is shown in Figure 4.16. A simple, but very meaningful, model in Six Sigma is that “ $y$  is a function of  $x$ ,” i.e.,  $y=f(x)$ , where  $y$  represents the response variable of importance for the customers and  $x$  represents input variables which are called factors in DOE. The question is which of the factors are important to reach good values on the response variable and how to determine the levels of the factors.

The design of experiments plays a major role in many engineering activities. For instance, DOE is used for

1. Improving the performance of a manufacturing process. The optimal values of process variables can be economically determined by application of DOE.

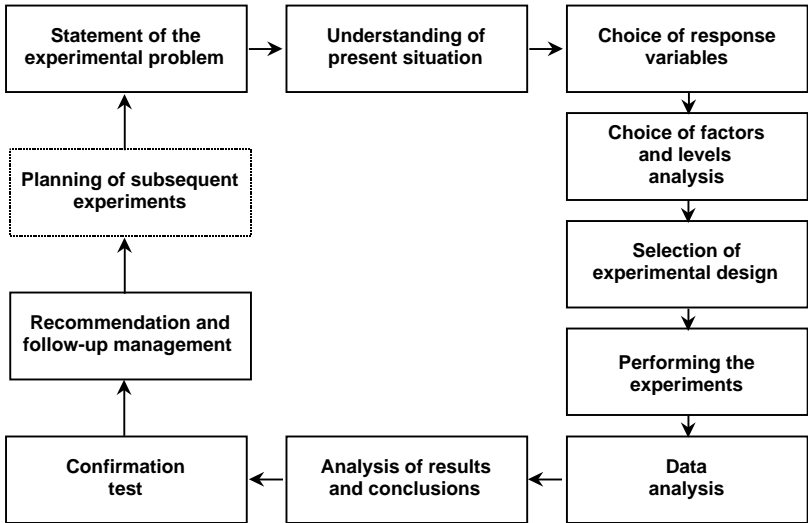

**Figure 4.16.** Outline of experimental design procedure

2. The development of new processes. The application of DOE methods early in process development can result in reduced development time, reduced variability of target requirements, and enhanced process yields.
3. Screening important factors.
4. Engineering design activities such as evaluation of material alternations, comparison of basic design configurations, and selection of design parameters so that the product is robust to a wide variety of field conditions.
5. Empirical model building to determine the functional relationship between  $x$  and  $y$ .

The tool, DOE, was developed in the 1920s by the British scientist Sir Ronald A. Fisher (1890–1962) as a tool in agricultural research. The first industrial application was performed in order to examine factors leading to improved barley growth for the Dublin Brewery. After its original introduction to the brewery industry, factorial design, a class of design in DOE, began to be applied in industries such as agriculture, cotton, wool and chemistry. George E. P. Box (1919–), an American

scientist, and Genichi Taguchi (1924–), a Japanese scientist, have contributed significantly to the usage of DOE where variation and design are the central considerations.

Large manufacturing industries in Japan, Europe and the US have applied DOE from the 1970s. However, DOE remained a specialist tool and it was first with Six Sigma that DOE was brought to the attention of top management as a powerful tool to achieve cost savings and income growth through improvements in variation, cycle time, yield, and design. DOE was also moved from the office of specialists to the corporate masses through the Six Sigma training scheme.

## *(2) Classification of design of experiments*

There are many different types of DOE. They may be classified as follows according to the allocation of factor combinations and the degree of randomization of experiments.

1. **Factorial design:** This is a design for investigating all possible treatment combinations which are formed from the factors under consideration. The order in which possible treatment combinations are selected is completely random. Single-factor, two-factor and three-factor factorial designs belong to this class, as do  $2^k$  ( $k$  factors at two levels) and  $3^k$  ( $k$  factors at three levels) factorial designs.
2. **Fractional factorial design:** This is a design for investigating a fraction of all possible treatment combinations which are formed from the factors under investigation. Designs using tables of orthogonal arrays, Plackett-Burman designs and Latin square designs are fractional factorial designs. This type of design is used when the cost of the experiment is high and the experiment is time-consuming.
3. **Randomized complete block design, split-plot design and nested design:** All possible treatment combinations are tested in these designs, but some form of restriction is imposed

on randomization. For instance, a design in which each block contains all possible treatments, and the only randomization of treatments is within the blocks, is called the randomized complete block design.

4. **Incomplete block design:** If every treatment is not present in every block in a randomized complete block design, it is an incomplete block design. This design is used when we may not be able to run all the treatments in each block because of a shortage of experimental apparatus or inadequate facilities.
5. **Response surface design and mixture design:** This is a design where the objective is to explore a regression model to find a functional relationship between the response variable and the factors involved, and to find the optimal conditions of the factors. Central composite designs, rotatable designs, simplex designs, mixture designs and evolutionary operation (EVOP) designs belong to this class. Mixture designs are used for experiments in which the various components are mixed in proportions constrained to sum to unity.
6. **Robust design:** Taguchi (1986) developed the foundations of robust design, which are often called parameter design and tolerance design. The concept of robust design is used to find a set of conditions for design variables which are robust to noise, and to achieve the smallest variation in a product's function about a desired target value. Tables of orthogonal arrays are extensively used for robust design. For references related to robust design, see Taguchi (1987), Park (1996) and Logothetis and Wynn (1989).

### *(3) Example of $2^3$ factorial design*

There are many different designs that are used in industry. A typical example is illustrated here. Suppose that three factors, A, B and C, each at two levels, are of interest. The design

is called a  $2^3$  factorial design, and the eight treatment combinations are written in Table 4.5 and they can be displayed graphically as a cube, as shown in Figure 4.17. We usually write the treatment combinations in standard order as (1), c, b, bc, a, ac, ab, abc.

There are actually three different notations that are widely used for the runs in the  $2k$  design. The first is the “+ and -” notation, and the second is the use of lowercase letters to identify the treatment combinations. The final notation uses 1 and 0 to denote high and low factor levels, respectively, instead of + and 1.

**Table 4.5.**  $2^3$  runs and treatment combinations

Run	A	B	C	Treatment combinations	A	B	C	Response data
	(+/- notation)				(1/0 notation)			
1	-	-	-	(1)	0	0	0	-2.5
2	-	-	+	c	0	0	1	-1.0
3	-	+	-	b	0	1	0	3.5
4	-	+	+	bc	0	1	1	1.0
5	+	-	-	a	1	0	0	-2.6
6	+	-	+	ac	1	0	1	-1.4
7	+	+	-	ab	1	1	0	4.0
8	+	+	+	abc	1	1	1	2.0

$$T = \sum y_i = 3.0$$

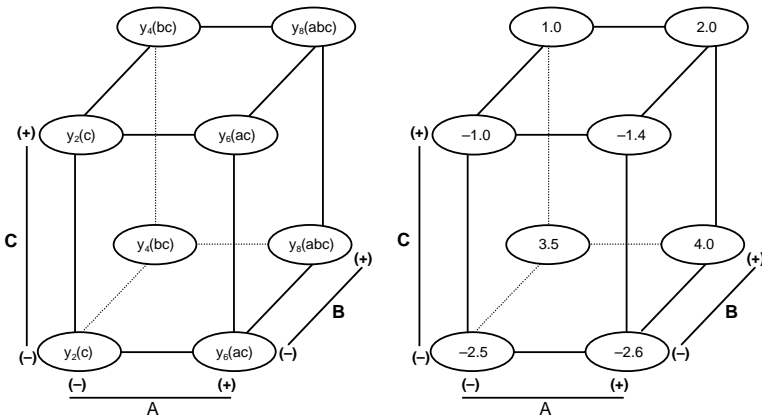

**Figure 4.17.**  $2^3$  factorial design

Suppose that a soft drink bottler is interested in obtaining more uniform fill heights in the bottles produced by his manufacturing process. The filling machine theoretically fills each bottle to the correct target height, but in practice, there is variation around this target, and the bottler would like to understand the sources of this variability and eventually reduce it. The process engineer can control three variables during the filling process as given below, and the two levels of experimental interest for each factor are as follows:

- A: The percentage of carbonation ( $A_0 = 10\%$ ,  $A_1 = 12\%$ )
- B: The operating pressure in the filler ( $B_0 = 25$  psi,  $B_1 = 30$  psi)
- C: The line speed ( $C_0 = 200$  bpm,  $C_1 = 250$  bpm)

The response variable observed is the average deviation from the target fill height observed in a production run of bottles at each set of conditions. The data that resulted from this experiment are shown in Table 4.5. Positive deviations are fill heights above the target, whereas negative deviations are fill heights below the target.

The analysis of variance can be done as follows. Here,  $T_i$  is the sum of four observations at the level of  $A_i$ , and  $T_{ij}$  is the sum of two observations at the joint levels of  $A_i B_j$ . The ANOVA (analysis of variance) table can be summarized as shown in Table 4.6.

$$\begin{aligned}
 S_T &= \text{total corrected sum of squares} \\
 &= \sum y_i^2 - \frac{(\sum y_i)^2}{8} \\
 &= (-2.5)^2 + (-1.0)^2 + \dots + (2.0)^2 - \frac{(3.0)^2}{8} = 48.095.
 \end{aligned}$$

$$\begin{aligned}
 S_A &= \frac{1}{8} \left[ T_{11\cdot} + T_{00\cdot} - T_{01\cdot} - T_{10\cdot} \right]^2 \\
 &= \frac{1}{8} \left[ ab + abc + (1) + c - b - bc - a - ac \right]^2 \\
 &= \frac{1}{8} \left[ 4.0+2.0+(-2.5)+(-1.0)-3.5-1.0-(-2.6)-(-1.4) \right]^2 \\
 &= 0.5.
 \end{aligned}$$

Similarly, we can find that  $S_B = 40.5$ ,  $S_C = 0.405$ . For the interaction sum of squares, we can show that

$$\begin{aligned}
 S_{A \times B} &= \frac{1}{8} \left[ T_{11\cdot} + T_{00\cdot} - T_{01\cdot} - T_{10\cdot} \right]^2 \\
 &= \frac{1}{8} \left[ ab + abc + (1) + c - b - bc - a - ac \right]^2 \\
 &= \frac{1}{8} \left[ 4.0+2.0+(-2.5)+(-1.0)-3.5-1.0-(-2.6)-(-1.4) \right]^2 \\
 &= 0.5.
 \end{aligned}$$

Similarly, we can find that  $S_{A \times C} = 0.005$  and  $S_{B \times C} = 6.48$ . The error sum of squares can be calculated as

$$S_e = S_T - (S_A + S_B + S_C + S_{A \times B} + S_{A \times C} + S_{B \times C}) = 0.08.$$

**Table 4.6.** ANOVA table for soft drink bottling problem

Source of variation	Sum of squares	Degrees of freedom	Mean square	F <sub>0</sub>
A	0.125	1	0.125	1.56
B	40.500	1	40.500	506.25
C	0.405	1	0.405	5.06
A×B	0.500	1	0.500	6.25
A×C	0.005	1	0.005	0.06
B×C	6.480	1	6.480	81.00
Error(e)	0.080	1	0.080	
<b>Total</b>	<b>48.095</b>	<b>7</b>		

Since the  $F_0$  value of  $A \times C$  is less than 1, we pool  $A \times C$  into the error term, and the pooled ANOVA table can be constructed as follows.

**Table 4.7.** Pooled ANOVA table for soft drink bottling problem

Source of variation	Sum of squares	Degrees of freedom	Mean square	$F_0$
A	0.125	1	0.125	2.94
B	40.500	1	40.500	952.94 **
C	0.405	1	0.405	9.53 $\Delta$
A×B	0.500	1	0.500	11.76 $\Delta$
B×C	6.480	1	6.480	152.47 **
Pooled error(e)	0.085	2	0.0425	
<b>Total</b>	<b>48.095</b>	<b>7</b>		

\*\* : Significant at 1% level.

$\Delta$  : Significant at 10% level.

To assist in the practical interpretation of this experiment, Figure 4.18 presents plots of the three main effects and the  $A \times B$  and  $B \times C$  interactions. Since  $A \times C$  is pooled, it is not plotted. The main effect plots are just graphs of the marginal response averages at the levels of the three factors. The interaction graph of  $A \times B$  is the plot of the averages of two responses at  $A_0B_0$ ,  $A_0B_1$ ,  $A_1B_0$  and  $A_1B_1$ . The interaction graph of  $B \times C$  can be similarly sketched. The averages are shown in Table 4.8.

**Table 4.8.** Averages for main effects and interactions

$A_0$	$A_1$	$B_0$	$B_1$	$C_0$	$C_1$	
0.25	0.50	-1.875	2.625	0.6	0.15	
$A_0$	$A_1$	$B_0$	$B_1$			
$B_0$	-1.75	-2.0		$C_0$	-2.55	3.75
$B_1$	2.25	3.0		$C_1$	-1.2	1.5

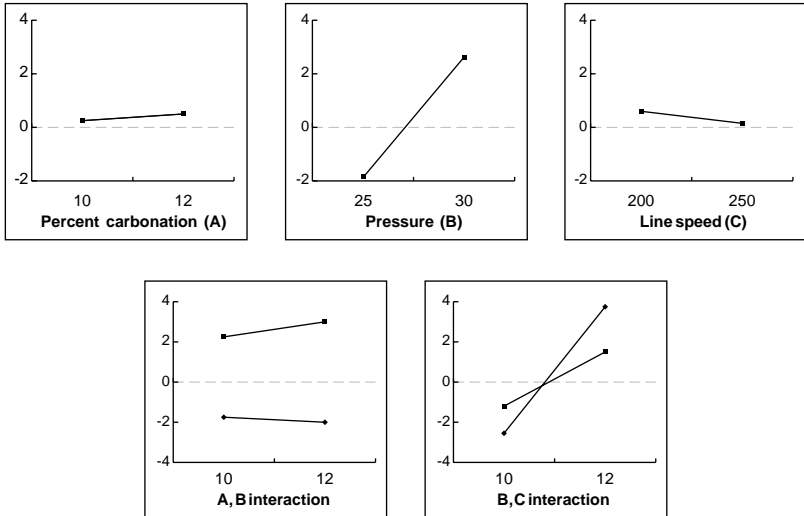

**Figure 4.18.** Main effects and interaction plots

Notice that two factors, A and B, have positive effects; that is, increasing the factor level moves the average deviation from the fill target upward. However, factor C has a negative effect. The interaction between B and C is very large, but the interaction between A and B is fairly small. Since the company wants the average deviation from the fill target to be close to zero, the engineer decides to recommend  $A_0B_0C_1$  as the optimal operating condition from the plots in Figure 4.18.

#### 4.7 Failure Modes and Effects Analysis (FMEA)

##### (1) Definition

Failure modes and effects analysis (FMEA) is a set of guidelines, a process, and a form of identifying and prioritizing potential failures and problems in order to facilitate process improvement. By basing their activities on FMEA, a manager, improvement team, or process owner can focus the energy and

resources of prevention, monitoring, and response plans where they are most likely to pay off. The FMEA method has many applications in a Six Sigma environment in terms of looking for problems not only in work processes and improvements but also in data-collection activities, Voice of the Customer efforts and procedures.

There are two types of FMEA; one is design FMEA and the other is process FMEA. Design FMEA applications mainly include component, subsystem, and main system. Process FMEA applications include assembly machines, work stations, gauges, procurement, training of operators, and tests. Benefits of a properly executed FMEA include the following:

- Prevention of possible failures and reduced warranty costs
- Improved product functionality and robustness
- Reduced level of day-to-day manufacturing problems
- Improved safety of products and implementation processes
- Reduced business process problems

## *(2) Design FMEA*

Within a design FMEA, manufacturing and/or process engineering input is important to ensure that the process will produce to design specifications. A team should consider including knowledgeable representation from design, test, reliability, materials, service, and manufacturing/process organizations. When beginning a design FMEA, the responsible design engineer compiles documents that provide insight into the design intent. Design intent is expressed as a list of what the design is expected to do. Table 4.9 shows a blank FMEA form. A team determines the design FMEA tabular entries following guidelines as described below.

- **Header information:** Documents the system/subsystem/component, and supplies other information about when the FMEA was created and by whom.
- **Item/function:** Contains the name and number of the analyzed item. Includes a concise, exact, and easy-to-understand explanation of the function of the item task.
- **Potential failure mode:** Describes ways a design could fail to perform its intended function.
- **Potential effect of failure:** Contains the effects of the failure mode on the function from an internal or external customer point of view.
- **Severity:** Assesses the seriousness of the effect of the potential failure mode to the next component, subsystem, or system, if it should occur. Estimation is typically based on a 1 to 10 scale where 10 is the most serious, 5 is low and 0 is no effect.
- **Classification:** Includes optional information such as critical characteristics that may require additional process controls.
- **Potential cause of failure:** Indicates a design weakness that causes the potential failure mode.
- **Occurrence:** Estimates the likelihood that a specific cause will occur. Estimation is usually based on a 1 to 10 scale where 10 is very high (failure is almost inevitable), 5 is low, and 1 is remote (failure is unlikely).
- **Current design controls:** Lists activities such as design verification tests, design reviews, DOEs, and tolerance analysis that ensure occurrence criteria.



- **Detection:** Assessment of the ability of the current design control to detect the subsequent failure mode. Assessment is based on a 1 to 10 scale where 10 is absolute uncertainty (there is no control), 5 is moderate (moderate chance that the design control will detect a potential cause), 1 is almost certain (design control will almost certainly detect a potential cause).
- **Risk priority number (RPN):** Product of severity, occurrence, and detection rankings. The ranking of RPN prioritizes design concerns.
- **Recommended action:** Intent of this entry is to institute actions.
- **Responsibility for recommended action:** Documents the organization and individual responsibility for recommended action.
- **Actions taken:** Describes implementation action and effective date.
- **Resulting RPN:** Contains the recalculated RPN resulting from corrective actions that affected previous severity, occurrence, and detection rankings. Blanks indicate no action.

Table 4.10 shows an example of a design FMEA which is taken from the FMEA Manual of Chrysler Ford General Motors Supplier Quality Requirements Task Force.



### **(3) Process FMEA**

For a process FMEA, design engineering input is important to ensure appropriate focus on important design needs. A team should consider including knowledgeable representation from design, manufacturing/process, quality, reliability, tooling, and operators.

Table 4.9 shows a blank FMEA form which can be simultaneously used for a design FMEA and for a process FMEA. The tabular entries of a process FMEA are similar to those of a design FMEA. Detailed explanations for these entries are not given here again. An example is given in Table 4.11 to illustrate the process FMEA.

## **4.8 Balanced Scorecard (BSC)**

The concept of a balanced scorecard became popular following research studies published in the Harvard Business Review articles of Kaplan and Norton (1992, 1993), and ultimately led to the 1996 publication of the standard business book on the subject, titled *The Balanced Scorecard* (Kaplan and Norton, 1996). The authors define the balanced scorecard (BSC) as “organized around four distinct performance perspectives – financial, customer, internal, and innovation and learning. The name reflects the balance provided between short- and long-term objectives, between financial and non-financial measures, between lagging and leading indicators, and between external and internal performance perspectives.”

As data are collected at various points throughout the organization, the need to summarize many measures – so that top-level leadership can gain an effective idea of what is happening in the company – becomes critical. One of the most popular and useful tools we can use to reach that high-level view is the BSC. The BSC is a flexible tool for selecting and displaying “key indicator” measures about the business in an easy-to-read format. Many organizations not involved in Six Sigma, including many government agencies, are using the BSC to establish common performance measures and keep a closer eye on the business.

**Table 4.11. Example: Process FMEA**

FMEA type (design or process) : Process		Project Name/Description : Cheetah/Change surface finish of part						Date(Orig) : 4/14								
Responsibility : Paula Hinkle		Prepared by : Paula Hinkle						Date(Rev) : 6/15								
Core Team : Sam Smith, Harry Adams, Hilton Dean, Harry Hawkins, Sue Watkins								Date(Key) :								
Design FMEA (Item/Function) Process FMEA (Function/Require.)	Potential Failure Mode	Potential Effect(s) of Failure	Current Controls	Current Controls	Recommended Actions	Responsibility and Target Completion Date	Actions Taken	Score								
Solder dipping	Excessive Solder wire Protrusion	Short to Shield cover	9	Flux wire termination	6	100% inspection	3	162	Automation/DOE/100% with go/no go gauge	Sam Smith 6/4	Done	9	4	2	72	
	Interlock base damage	Visual defects	7	Long solder time	8	Automatic solder tool	3	168	Automation/DOE/ Define visual criteria	Harry Adams 5/15	Done	7	4	2	56	
			7	High temp	8	Automatic solder tool/ SPC	3	168	Automation/DOE	Hilton Dean 5/15	Done	7	4	2	56	
Marking	Delamination of interlock base	Visual defects	7	See interlock Base damage	8	Automatic solder tool/ SPC	3	168	Automation/DOE	Sue Watkins 5/15	Done	7	4	2	56	
			7	Moisture in Interlock base	5	No SPC	7	245	Inform supplier to Control molding cond.	Harry Hawkins 5/15	Done	7	2	7	98	
	Oxidization of golden plating pins	Contact problem/no signal	8	Not being Cleaned in time	7	Clean in 30 minutes after solder dip	5	280	Improve quality of Plating define criteria With customer	Sam Smith 5/15	Done	8	2	5	80	
	Marking permanency	Legible marking /customer dissatisfaction	6	Marking ink	4	SPC	2	48	None							
			6	Curing	5	UV energy and SPC	3	90	None							
			6	Smooth Marking surface	8	None	6	288	Rough surface	Sam Smith 5/15	Change Interlock Texture surface	6	3	6	108	

A number of organizations that have embraced Six Sigma methodology as a key strategic element in their business planning have also adopted the BSC, or something akin to it, for tracking their rate of performance improvement. One of those companies is General Electric (GE). In early 1996, Jack Welch, CEO of GE, announced to his top 500 managers his plans and aspirations regarding a new business initiative known as Six Sigma (Slator, 2000). When the program began, GE selected five criteria to measure progress toward an aggressive Six Sigma goal. Table 4.12 compares the GE criteria with the four traditional BSC criteria. We have ordered the four GE criteria so that they align with the corresponding traditional BSC measures. The fifth GE criterion, “supplier quality,” can be considered as a second example of the BSC “financial” criteria.

**Table 4.12.** Measurement criteria: BSC versus GE

Balanced Scorecard	General Electric
1. Financial	1. Cost of poor quality (COPQ)
2. Customer	2. Customer satisfaction
3. Internal	3. Internal process performance
4. Innovation and learning	4. Design for manufacturability (DFM)
	5. Supplier quality

In today’s business climate, the term “balanced scorecard” can refer strictly to the categories originally defined by Kaplan and Norton (1996), or it can refer to the more general “family of measures” approach involving other categories. GE, for example, uses the BSC approach but deviates from the four prescribed categories of the BSC when it is appropriate. Godfrey (1999) makes no demands on the BSC categories other than that they track goals that support the organization’s strategic plan.

For an example of a BSC, the following BSC can be obtained for an internal molding process.

**Table 4.13.** Internal process BSC

Process name	CTQ	LSL	USL	Mean	Standard deviation	$Z_l$	$Z_s$	DPMO
Molding	Diameter	-1	1	-0.021	0.340	2.71	4.21	3,338
	Curvature		0.57	0.165	0.099	4.06	5.56	25
	Distance	-1.14	1.14	0.022	0.290	3.74	5.24	91
	Contraction	90		98.94	2.46	3.62	5.12	147
	Temperature Index	1.0	2.1	1.57	0.16	3.32	4.82	458
<b>Average</b>						3.15	4.65	812

In Table 4.13,  $Z_l$  and  $Z_s$  are the long-term and short-term critical values of standard normal distribution, respectively. Since the average DPMO of this molding process is 812, the sigma quality level is 4.65. Through this BSC, we can judge whether this process is satisfactory or not.

## 5. Six Sigma and Other Management Initiatives

---

### 5.1 Quality Cost and Six Sigma

#### (1) *Definition of quality cost*

Quality costs are the costs incurred for quality management. Feigenbaum (1961) in his book of *Total Quality Control* mentioned that quality costs consist of three major categories: prevention, appraisal and failure. In addition, the area of failure cost is typically broken up into two subcategories: internal failure and external failure.

Prevention costs are devoted to keeping defects from occurring in the first place. They include quality training, quality planning and vendor surveys. Appraisal costs are associated with efforts such as quality audits, testing and inspection to maintain quality levels by means of formal evaluations of quality systems. Failure costs refer to after-the-fact efforts devoted to products that do not meet specifications or that fail to meet customers' expectations. Table 5.1 gives examples of individual cost elements within each of these major categories.

#### (2) *Proportion of quality costs*

To pinpoint the areas which merit the highest priority of quality-control effort, a breakdown of overall quality costs by major divisions, product lines or areas of the process flow is often needed. Figure 5.1 shows the quality costs for three separate divisions, A, B and C, in a company. Division A shows a disproportionately high failure rate with very little prevention and appraisal effort. Appraisal cost appears high for division B, but failure costs are quite reduced compared with division A. External failure, internal failure, appraisal and prevention are quite balanced in division C, and consequently quality costs can be reduced. This indicates that a greater pro-

**Table 5.1.** Categories of quality costs and their contents

<b>Category</b>	<b>Contents</b>
<b>Prevention cost</b> (P-cost)	<ol style="list-style-type: none"> <li>1. Quality training</li> <li>2. Process capability studies</li> <li>3. Vendor surveys</li> <li>4. Quality planning and design</li> <li>5. Other prevention expenses</li> </ol>
<b>Appraisal cost</b> (A-cost)	<ol style="list-style-type: none"> <li>1. All kinds of testing and inspection</li> <li>2. Test equipment</li> <li>3. Quality audits and reviews</li> <li>4. Laboratory expenses</li> <li>5. Other appraisal expenses</li> </ol>
<b>Failure cost (F-cost)</b> Internal failure cost	<ol style="list-style-type: none"> <li>1. Scrap and rework</li> <li>2. Design changes</li> <li>3. Excess inventory cost</li> <li>4. Material procurement cost</li> <li>5. Other internal failure expenses</li> </ol>
<b>Failure cost (F-cost)</b> External failure cost	<ol style="list-style-type: none"> <li>1. After-service and warranty costs</li> <li>2. Customer complaint visits</li> <li>3. Returns and recalls</li> <li>4. Product liability suits</li> <li>5. Other external failure expenses</li> </ol>

portion of existing preventive and appraising efforts should be expended in reducing failure costs. This strategy will eventually reduce the overall quality costs. The optimal proportions of quality costs depend on the type of business involved. However, it is reported that the quality cost could be reduced to as much as approximately 10% level of total sales value.

**(3) Cost of poor quality**

The cost of poor quality (COPQ) is the total cost incurred by high quality costs and poor management. Organizations, both public and private, that can virtually eliminate the COPQ can become the leaders of the future. Conway (1992)

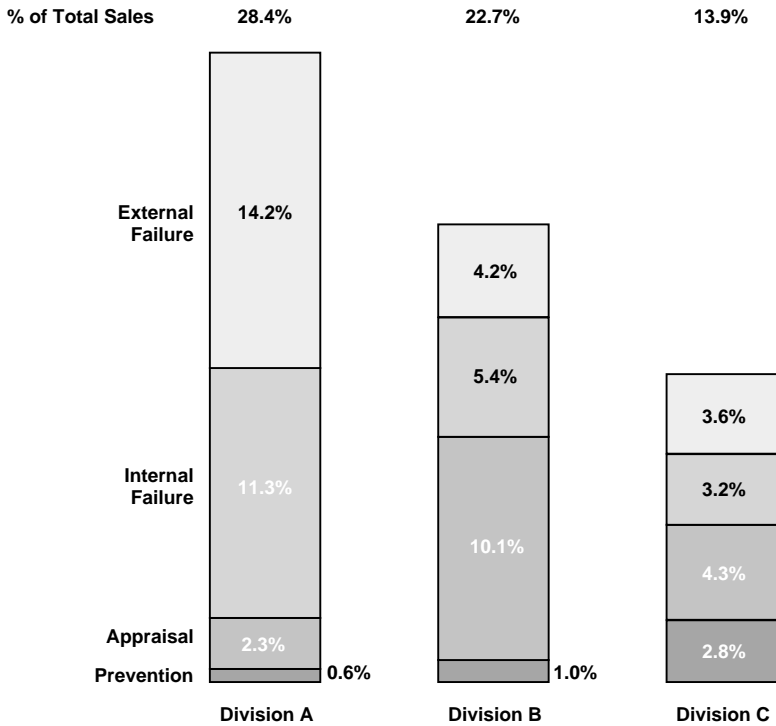

**Figure 5.1.** Breakdown of quality costs

claims that in most organizations 40% of the total effort, both human and mechanical, is wasted. If that waste can be eliminated or significantly reduced, the per-unit price that must be charged for goods and services to yield a good return on investment is greatly reduced, and often ends up being a price that is competitive on a global basis. One of the great advantages of Six Sigma is to reduce the COPQ, and hence, to improve profitability and customer satisfaction.

As the quality movement progressed, it became obvious that the costs associated with quality could represent as much as 20 to 40% of total sales value (see Juran, 1988), and that many of these costs were “hidden” (not directly captured) on the income statement or balance sheet. These hidden quality costs are those shown below the water line in Figure 5.2.

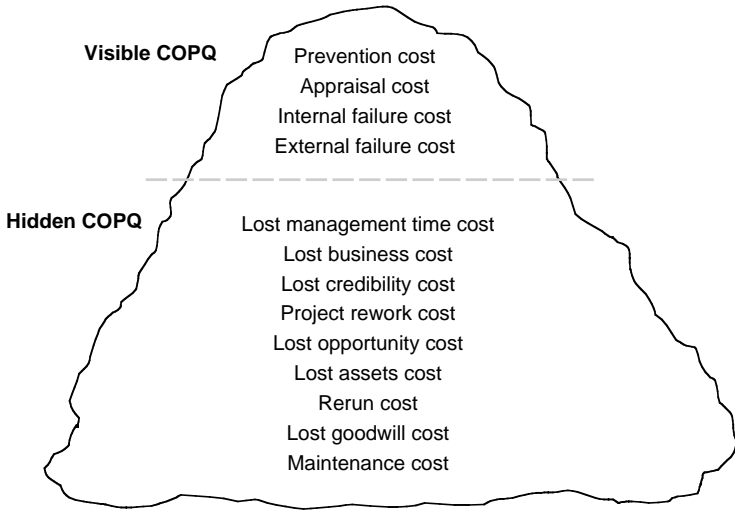

**Figure 5.2.** Visible and hidden costs of poor quality

The addition of technical specialists within the quality department helped with defining and focusing on these hidden quality costs. Since large COPQ represents unsatisfactory products or practices, that, if eliminated, could significantly improve the profitability of an organization. Over a period of decades, a number of surprising facts surfaced concerning COPQ (Juran, 1988):

- Quality-related costs were much higher than financial reports tended to indicate.
- Quality costs were incurred not only in manufacturing but in support areas as well.
- While many of these costs were avoidable, there was no person or organization directly responsible for reducing them.

An excellent Six Sigma strategy should directly attack the COPQ, whose issues can dramatically affect a business. Wisely applied Six Sigma techniques can help eliminate or reduce many of the issues that affect overall COPQ. The concept of

COPQ can help identify Six Sigma projects. It would be ideal if a Pareto chart of the monetary magnitude of the 20 COPQ subcategories listed in Table 5.1 could be created so that areas for improvement could be identified.

## 5.2 TQM and Six Sigma

While Six Sigma is definitely succeeding in creating some impressive results and culture changes in some influential organizations, it is certainly not yet a widespread success. Total Quality Management (TQM) seems less visible in many businesses than it was in the early 1990s. However, many companies are still engaged in improvement efforts based on the principles and tools of TQM. It appears at least in Korea that Six Sigma is succeeding while TQM is losing its momentum.

One of the problems that plagued many of the early TQM initiatives was the preeminence placed on quality at the expense of all other aspects of the business. Some organizations experienced severe financial consequences in the rush to make quality “first among equals.” The disconnection between management systems designed to measure customer satisfaction and those designed to measure provider profitability often led to unwise investments in quality, which has been often practiced in TQM.

Ronald Snee (1999) points out that although some people believe it is nothing new, Six Sigma is unique in its approach and deployment. He defines Six Sigma as a strategic business improvement approach that seeks to increase both customer satisfaction and an organization’s financial health. Snee goes on to claim that the following eight characteristics account for Six Sigma’s increasing bottom-line (net income or profit) success and popularity with executives.

- Bottom-line results expected and delivered
- Senior management leadership
- A disciplined approach (DMAIC)
- Rapid (3–6 months) project completion
- Clearly defined measures of success

- Infrastructure roles for Six Sigma practitioners and leadership
- Focus on customers and processes
- A sound statistical approach to improvement

Other quality initiatives including TQM have laid claim to a subset of these characteristics, but only Six Sigma attributes its success to the simultaneous application of all eight.

Six Sigma is regarded as a vigorous rebirth of quality ideals and methods, as these are applied with even greater passion and commitment than often was the case in the past. Six Sigma is revealing a potential for success that goes beyond the levels of improvement achieved through the many TQM efforts. Some of the mistakes of yesterday's TQM efforts certainly might be repeated in a Six Sigma initiative if we are not careful.

A review of some of the major TQM pitfalls, as well as hints on how the Six Sigma system can keep them from derailing our efforts is listed below.

### ***1. Links to the business and bottom-line success:***

In TQM, quality often was a “sidebar” activity, separated from the key issues of business strategy and performance. The link to the business and bottom-line success was undermined, despite the term “total” quality, since the effort actually was limited to product and manufacturing functions. Six Sigma emphasizes reduction of costs, thereby contributing to the bottom-line, and participation of three major areas: manufacturing, R&D and service parts.

### ***2. Top-level management leadership:***

In many TQM efforts, top-level management's skepticism has been apparent, or their willingness to drive quality ideas has been weak. Passion for and belief in Six Sigma at the very summit of the business is unquestioned in companies like Motorola, GE, Allied Signal (now Honeywell), LG and Samsung. In fact, top-level management involvement is the beginning of Six Sigma.

**3. *Clear and simple message:***

The fuzziness of TQM started with the word “quality” itself. It is a familiar term with many shades of meaning. In many companies, Quality was an existing department with specific responsibilities for “quality control” or “quality assurance,” where the discipline tended to focus more on stabilizing rather than improving processes. Also TQM does not provide a clear goal at which to aim. The concept of Six Sigma is clear and simple. It is a business system for achieving and sustaining success through customer focus, process management and improvement, and the wise use of facts and data. A clear goal (3.4 DPMO or  $6\sigma$  quality level) is the centerpiece of Six Sigma.

**4. *Effective training:***

TQM training was ineffective in the sense that the training program was not so systematic. Six Sigma divides all the employees into five groups (WB, GB, BB, MBB and Champion), and it sets very demanding standards for learning, backing them up with the necessary investment in time and money to help people meet those standards.

**5. *Internal barriers:***

TQM was a mostly “departmentalized” activity in many companies, and it seemed that TQM failed to break down internal barriers among departments. Six Sigma places priority on cross-functional process management, and cross-functional project teams are created, which eventually breaks down internal barriers.

**6. *Project team activities:***

TQM utilized many “quality circles” of blue-collar operators and workers, and not many “task force teams” of white-collar engineers even if they are needed. Six Sigma demands a lot of project teams of BBs and GBs, and the project team activities are one of the major sources of bottom-line and top-line success. The difference between quality circles and Six Sigma project team activities was already explained in Chapter 2.

### **5.3 ISO 9000 Series and Six Sigma**

ISO (International Organization for Standardization) 9000 series standards were first published in 1987, revised in 1994, and re-revised in 2000 by the ISO. The 2000 revision, denoted by ISO 9000:2000, has attracted broad expectations in industry. As of the year 2001, more than 300,000 organizations worldwide have been certified to the ISO 9000 series standards. It embodies a consistent pair of standards, ISO 9001:2000 and ISO 9004:2000, both of which have been significantly updated and modernized. The ISO 9001:2000 standard specifies requirements for a quality management system for which third-party certification is possible, whereas ISO 9004:2000 provides guidelines for a comprehensive quality management system and performance improvement through Self-Assessment.

The origin and historical development of ISO 9000 and Six Sigma are very different. The genesis of ISO 9000 can be traced back to the standards that the British aviation industry and the U.S. Air Force developed in the 1920s to reduce the need for inspection by approving the conformance of suppliers' product quality. These standards developed into requirements for suppliers' quality assurance systems in a number of western countries in the 1970s. In 1987 they were amalgamated into the ISO 9000 series standards.

Independent of ISO 9000, the same year also saw the launch of Six Sigma at Motorola and the launch of Self-Assessment by means of the Malcolm Baldrige National Quality Award in USA. Both Six Sigma and Self-Assessment can be traced back to Walter A. Shewhart and his work on variation and continuous improvement in the 1920s. It was Japanese industry that pioneered a broad application of these ideas from the 1950s through to the 1970s. When variation and continuous improvement caught the attention of some of the American business leaders in the late 1980s, it took the form of the Malcolm Baldrige National Quality Award, on a national level, and of Six Sigma at Motorola.

Some people are wondering if the ISO 9000:2000 series

standards make Six Sigma superfluous. They typically refer to clause 8 of ISO 9001: “Measurement, analysis, improvement.” It requires that companies install procedures in operations for the measurement of processes and data analysis using statistical techniques with the demonstration of continuous improvement as shown in Figure 5.3. They also partly refer to the ISO 9004:2000 standards that embody guidelines and criteria for Self-Assessment similar to the national quality awards.

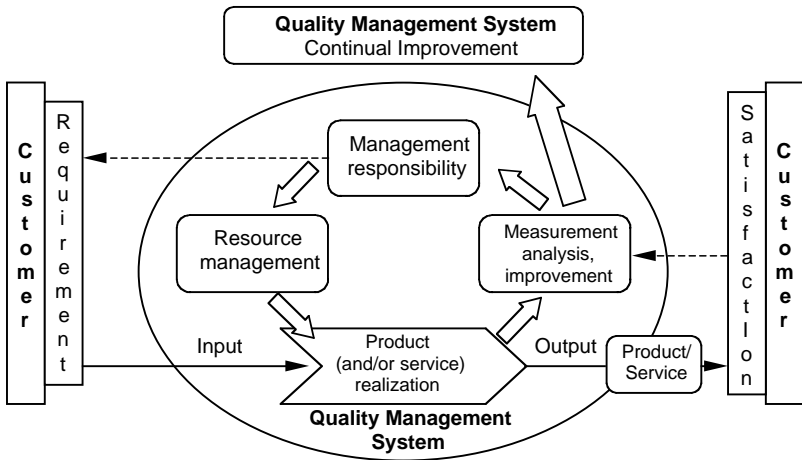

**Figure 5.3.** The new process model in ISO 9000:2000

The author firmly believes that Six Sigma is needed regardless of whether a company is compliant with the ISO 9000 series. The two initiatives are not mutually exclusive and the objectives in applying them are different. A Six Sigma program is applied in organizations based on its top-line and bottom-line rationales. The primary objective for applying the ISO 9000 series standards is to demonstrate the company’s capability to consistently provide conforming products and/or services. Therefore, the ISO 9000 series standard falls well short of making Six Sigma superfluous.

The ISO 9000 series standards have from their early days been regarded and practiced by industry as a minimum set of requirements for doing business. The new ISO 9000:2000 stan-

dards do not represent a significant change to this perspective. Six Sigma on the other hand, aims at world-class performance, based on a pragmatic framework for continuous improvement.

The author believes that Six Sigma is superior in such important areas as rate of improvement, bottom-line and top-line results, customer satisfaction, and top-level management commitment. However, considering the stronghold of ISO 9000 in industry, Six Sigma and ISO 9000 are likely to be applied by the same organization, but for very different purposes.

## **5.4 Lean Manufacturing and Six Sigma**

### *(1) What is lean manufacturing?*

Currently there are two premier approaches to improving manufacturing operations. One is lean manufacturing (hereinafter referred to as “lean”) and the other is Six Sigma.

Lean evaluates the entire operation of a factory and restructures the manufacturing method to reduce wasteful activities like waiting, transportation, material hand-offs, inventory, and over-production. It reduces variation associated with manufacturing routings, material handling, storage, lack of communication, batch production and so forth. Six Sigma tools, on the other hand, commonly focus on specific part numbers and processes to reduce variation. The combination of the two approaches represents a formidable opponent to variation in that it includes both layout of the factory and a focus on specific part numbers and processes.

Lean and Six Sigma are promoted as different approaches and different thought processes. Yet, upon close inspection, both approaches attack the same enemy and behave like two links within a chain – that is, they are dependent on each other for success. They both battle variation, but from two different points of view. The integration of Lean and Six Sigma takes two powerful problem-solving techniques and bundles them into a powerful package. The two approaches should be viewed as complements to each other rather than as equiva-

lents of or replacements for each other (Pyzdek, 2000).

In practice, manufacturers that have widely adopted lean practices record performance metrics superior to those achieved by plants that have not adopted lean practices. Those practices cited as lean in a recent industrial survey (Jusko, 1999) include

- quick changeover techniques to reduce setup time;
- adoption of manufacturing cells in which equipment and workstations are arranged sequentially to facilitate small-lot, continuous-flow production;
- just-in-time (JIT) continuous-flow production techniques to reduce lot sizes, setup time, and cycle time; and,
- JIT supplier delivery in which parts and materials are delivered to the shop floor on a frequent and as-needed basis.

## *(2) Differences between Lean and Six Sigma*

There are some differences between Lean and Six Sigma as noted below.

- Lean focuses on improving manufacturing operations in variation, quality and productivity. However, Six Sigma focuses not only on manufacturing operations, but also on all possible processes including R&D and service areas.
- Generally speaking, a Lean approach attacks variation differently than a Six Sigma system does (Denecke, 1998) as shown in Figure 5.4. Lean tackles the most common form of process noise by aligning the organization in such a way that it can begin working as a coherent whole instead of as separate units. Lean seeks to co-locate, in sequential order, all the processes required to produce a product. Instead of focusing on the part number, Lean focuses on product flow and on the operator. Setup time, machine maintenance and routing of processes are important measures in Lean. However, Six Sigma focus-

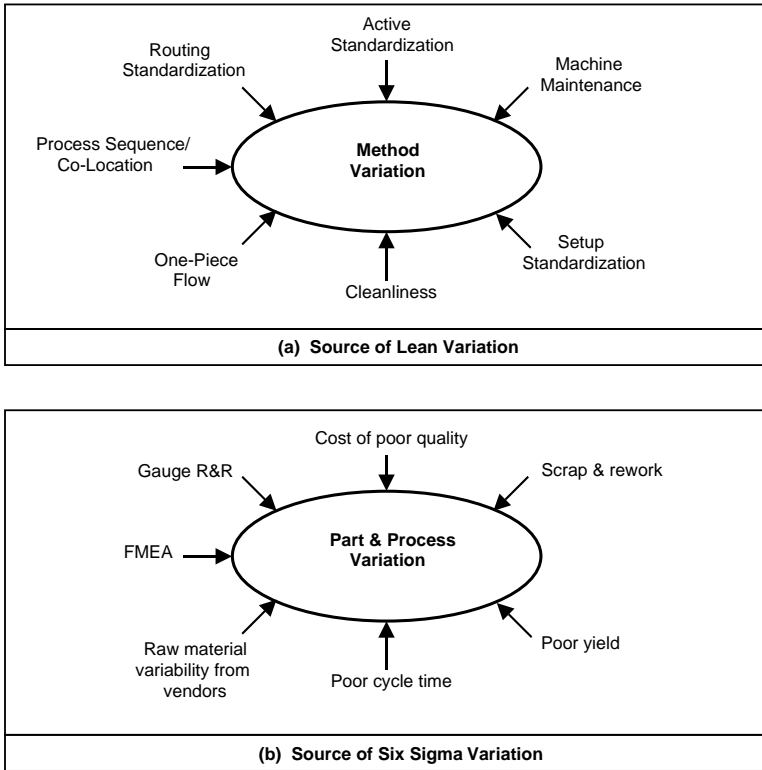

**Figure 5.4.** Variation as viewed by lean manufacturing and Six Sigma

- es on defective rates and costs of poor quality due to part variation and process variation based on measured data.
- The data-driven nature of Six Sigma problem-solving lends itself well to lean standardization and the physical rearrangement of the factory. Lean provides a solid foundation for Six Sigma problem-solving where the system is measured by deviation from and improvements to the standard.
  - While Lean emphasizes standardization and productivity, Six Sigma can be more effective at tackling process noise and cost of poor quality.

### (3) Synergy effect

The author believes that Lean and Six Sigma, working together, represent a formidable weapon in the fight against process variation. Six Sigma methodology uses problem-solving techniques to determine how systems and processes operate and how to reduce variation in processes. In a system that combines the two philosophies, Lean creates the standard and Six Sigma investigates and resolves any variation from the standard. In addition, the techniques of Six Sigma should be applied within an organization's processes to reduce defects, which can be a very important prerequisite to the success of a Lean project.

## 5.5 National Quality Awards and Six Sigma

The national quality awards such as the Malcolm Baldrige National Quality Award (MBNQA), the European Quality Award, the Deming Prize and the Korean National Quality Grand Prize provide a set of excellent similar criteria for helping companies to understand performance excellence in operations. Table 5.2 shows the list of these criteria. Let us denote these criteria and efforts directed toward performance excellence for quality awards as a Self-Assessment program. Then, is Self-Assessment and Six Sigma the same?

**Table 5.2.** Overview of the criteria in some Self-Assessment models

Malcolm Baldrige National Quality Award	European Quality Award	Deming Prize	Korean National Quality Grand Prize
<ol style="list-style-type: none"> <li>1. Leadership</li> <li>2. Strategic planning</li> <li>3. Customer &amp; market share</li> <li>4. Information &amp; analysis</li> <li>5. Human resource focus</li> <li>6. Process management</li> <li>7. Business results</li> </ol>	<ol style="list-style-type: none"> <li>1. Leadership</li> <li>2. Policy &amp; strategy</li> <li>3. People</li> <li>4. Partnership &amp; resources</li> <li>5. Processes</li> <li>6. Customer results</li> <li>7. People results</li> <li>8. Society results</li> <li>9. Key performance results</li> </ol>	<ol style="list-style-type: none"> <li>1. Organization</li> <li>2. Policies</li> <li>3. Information</li> <li>4. Standardization</li> <li>5. Human resources</li> <li>6. Quality assurance</li> <li>7. Maintenance</li> <li>8. Improvement</li> <li>9. Effects</li> <li>10. Future plans</li> </ol>	<ol style="list-style-type: none"> <li>1. Leadership</li> <li>2. Strategic planning</li> <li>3. Customer satisfaction</li> <li>4. Information &amp; analysis</li> <li>5. Human resource management</li> <li>6. Process management</li> <li>7. Business results</li> </ol>

Some evidence indicates a relationship between Self-Assessment and Six Sigma. Firstly, since the launch of the MBNQA in 1987, at least two companies have received the prestigious award largely due to their Six Sigma program. They are Motorola in 1988 and Defence Systems Electronics Group in 1992 (now Raytheon TI Systems). Secondly, a number of companies strongly promoting Self-Assessment are now launching Six Sigma programs. The most well known is probably Solectron, the only two-time recipient of the MBNQA in 1991 and 1997, which launched Six Sigma in 1999. Thirdly, the achievement towards excellence made by companies applying Six Sigma is as much as 70% improvement in process performance per year.

However, there are some significant differences. While Self-Assessment is heavily diagnostic in nature with most criteria that guide companies towards excellence, Six Sigma is a much more action-oriented and pragmatic framework embodying the improvement methodology, tools, training and measurements necessary to move towards world-class performance. Six Sigma heavily focuses on improvement projects to generate cost savings and revenue growth with company-wide involvement of employees. On the other hand, Self-Assessment has been criticized for contributing meagerly in terms of financial benefits and for depending solely on a cumbersome evaluation practice by a team of in-house experts. Furthermore, it does not in a systematic way involve the broad mass of rank-and-file employees to the extent that Six Sigma does.

However, the two kinds of initiatives may very well support and complement each other. While Self-Assessment indicates important improvement areas, Six Sigma guides the action-oriented improvement process. They share the objective of excellence in operations. It is believed that Six Sigma constitutes a road to performance excellence via the most pragmatic way.

## 6. Further Issues for Implementation of Six Sigma

---

### 6.1 Seven Steps for Six Sigma Introduction

When a company intends to introduce Six Sigma for its new management strategy, we would like to recommend the following seven-step procedures:

1. Top-level management commitment for Six Sigma is first and foremost. The CEO of the corporation or business unit should genuinely accept Six Sigma as the management strategy. Then organize a Six Sigma team and set up the long-term Six Sigma vision for the company.
2. Start Six Sigma education for Champions first. Then start the education for WBs, GBs, BBs and MBBs in sequence. Every employee of the company should take the WB education first and then some of the WBs receive the GB education, and finally some of the GBs receive the BB education. However, usually MBB education is practiced in professional organizations.
3. Choose the area in which Six Sigma will be first introduced.
4. Deploy CTQs for all processes concerned. The most important is the company's deployment of big CTQy from the standpoint of customer satisfaction. Appoint BBs as full-time project leaders and ask them to solve some important CTQ problems.
5. Strengthen the infrastructure for Six Sigma, including measurement systems, statistical process control (SPC), knowledge management (KM), database management system (DBMS) and so on.
6. Designate a Six Sigma day each month, and have the progress of Six Sigma reviewed by top-level management.

7. Evaluate the company's Six Sigma performance from the customers' viewpoint, benchmark the best company in the world, and revise the Six Sigma roadmap if necessary. Go to step 1 for further improvement.

First of all, a handful or a group of several members should be appointed as a Six Sigma team to handle all kinds of Six Sigma tasks. The team is supposed to prepare proper education and the long-term Six Sigma vision for the company. We can say that this is the century of the 3Cs, which are Changing society, Customer satisfaction and Competition in quality. The Six Sigma vision should be well matched to these 3Cs. Most importantly, all employees in the company should agree to and respect this long-term vision.

Second, Six Sigma can begin from proper education for all classes of the company. The education should begin from the top managers, so called Champions. If Champions do not understand the real meaning of Six Sigma, there is no way for Six Sigma to proceed further in the company. After Champion's education, GB→BB→MBB education should be completed in sequence.

Third, we can divide Six Sigma into three parts according to its characteristics. They are R&D Six Sigma, manufacturing Six Sigma, and Six Sigma for non-manufacturing areas. The R&D Six Sigma is often called DFSS (Design for Six Sigma). It is usually not wise to introduce Six Sigma to all areas at the same time. The CEO should decide the order of introduction to these three areas. It is common to introduce Six Sigma to manufacturing processes first, and then service areas and R&D areas. However, the order really depends on the current circumstances of the company.

Fourth, deploy CTQs for all processes concerned. These CTQs can be deployed by policy management or by management by objectives. Some important CTQs should be given to BBs to solve as project themes. In principle, the BBs who lead the project teams work as full-time workers until the projects are finished.

Fifth, in order to firmly introduce Six Sigma, some basic infrastructure is necessary such as scientific management tools of SPC, KM, DBMS and ERP (enterprise resources planning). In particular, efficient data acquisition, data storage, data analysis and information dissemination are necessary.

Sixth, one day each month is declared as Six Sigma day. On this day, the CEO should personally check the progress of Six Sigma. All types of presentation of Six Sigma results can be given, and awards can be presented to persons who performed excellently in fulfilling Six Sigma tasks. If necessary, seminars relating to Six Sigma can be held on this day.

Lastly, all process performances are evaluated to investigate whether they are being improved. The benchmarked company's performance should be used for process evaluation. Revise your vision or roadmap of Six Sigma, if necessary, and repeat again the innovation process.

## **6.2 IT, DT and Six Sigma**

### **(1) Emergence of DT**

It is well known that the modern technology for the 21st century is regarded as based on the following 6Ts. They are:

- IT : Information Technology
- BT : Bio-Technology
- NT : Nano-Technology
- ET : Environment Technology
- ST : Space Technology
- CT : Culture Technology

We believe that one more T should be added to these 6Ts, which is DT, data technology.

Definition of DT (data technology): DT is a scientific methodology which deals with

- Measurement, collection, storage and retrieval techniques of data;

- Statistical analysis of data and data refinement
- Generation of information and inference from data
- Statistical/computational modeling from data
- Creation of necessary knowledge from data information
- Diagnosis and control of current events from statistical models and,
- Prediction of unforeseen events from statistical models for the future.

DT is an essential element for Six Sigma, and in general for national competitiveness. The importance of DT will rapidly expand in this knowledge-based information society.

## *(2) Difference between IT and DT*

Many believe that DT is a subset of IT. This argument may be true if IT is interpreted in a wide sense. Generally speaking, however, IT is defined in a narrow sense as follows.

Definition of IT (information technology): IT is an engineering methodology which deals with

- Presentation and control of raw data and information created by DT;
- Efficient data/information and image transmission and communication;
- Manufacturing technology of electronic devices for data/information transmission and communication;
- Production technology of computer-related machines and software; and,
- Engineering tools and support for knowledge management.

Korea is very strong in IT industries such as the Internet, e-business, mobile phones, communication equipment and computer-related semiconductors.

The difference between DT and IT can be seen in the information flow as shown in Figure 6.1.

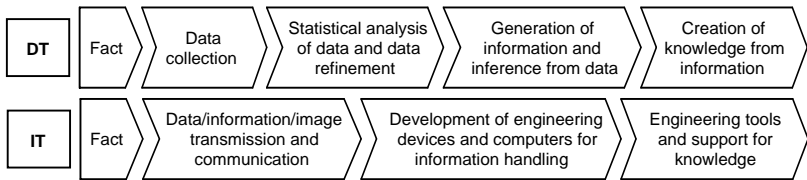

**Figure 6.1.** Information flow of DT and IT

DT is mainly concerned with data collection, statistical analysis of data, generation of information, and creation of necessary knowledge from information. However, IT is mainly concerned with data/information/image transmission and communication, and development of engineering devices and computers for information handling. Also IT is concerned with engineering tools for knowledge management. Generally speaking, DT forms the infrastructure of IT. Without DT, IT would have limitations in growth. DT is software-oriented, but IT is hardware-oriented and systems-oriented. Without IT, DT cannot be well visualized. IT is the vehicle for DT development.

Table 6.1 shows the differences between DT and IT in terms of characteristics, major products, major study fields and advanced levels in Korea.

**Table 6.1.** Comparison of DT and IT

Contents	DT	IT
Major characteristics	Software-oriented, scientific approach for data analysis, statistical modeling for future prediction	Hardware & systems-oriented engineering approach for transmission & communication of data/information/image
Major products	Software such as DBMS, CRM, SPC, ERP, Statistics, Data-mining, Simulation, and Cryptography	Communication systems and auxiliary software, Computers, Semiconductors, Electronic devices, Measuring and Control devices
Major study fields	Mathematics, Statistics, Information Science, Computer Science, Management Science	Computer engineering, Electronic/communication engineering, Control & Systems engineering
Advanced level of Korea	Low	High

(3) *Knowledge triangle*

It is said that the 21st century is the knowledge-based information society. We can think about the knowledge triangle as shown in Figure 6.2 in which DT and IT play important roles.

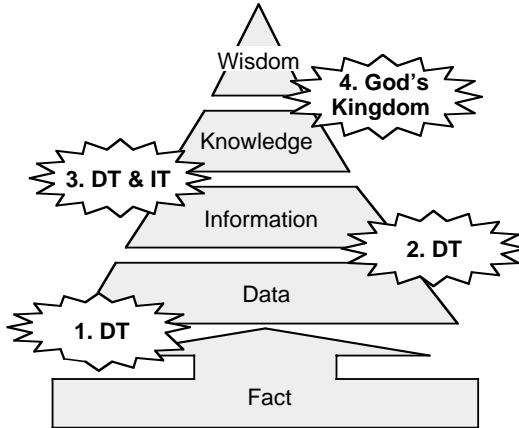

**Figure 6.2.** The knowledge triangle

In each step, the following activities are usually implemented.

**Table 6.2.** Major activities in each step of knowledge triangle

Step	Major Activities
1	Measurement, Data refinement, Sampling design, Design of experiments, Meta-data management, Gauge R&R test
2	Data analysis and modeling, Data-mining, Data redefinition for application, Diagnosis and control, Prediction modeling
3	Output summary, Valuation, Remodeling, Information clustering
4	Knowledge generation from Information clustering

#### (4) Scope of DT

The scope of DT can be divided into three categories: management, multiplication and execution. Management DT comes first, and then multiplication DT, and finally execution DT provides valuation and profit generation for the organization concerned. The scope can be shown sequentially as in Figure 6.3.

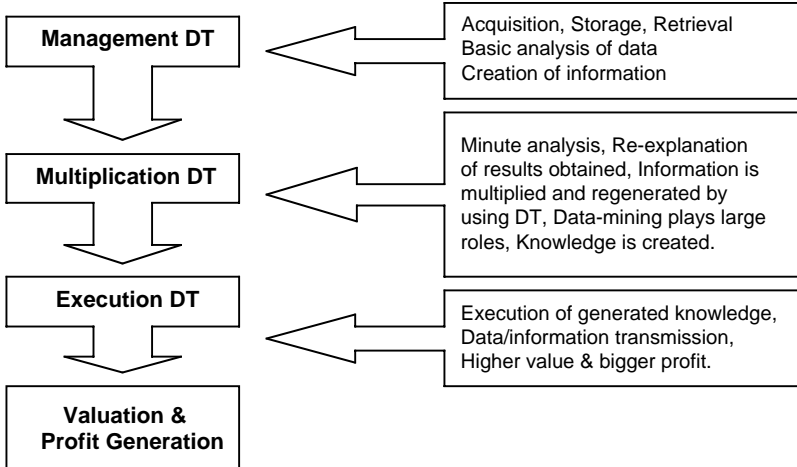

Figure 6.3. Scope of DT

#### (5) Loss due to insufficient DT

A weak DT can result in big loss to a company, to a society and to a nation. Some examples of national loss due to insufficient DT are as follows.

##### Economic crisis in 1997:

Korea faced an economic crisis in 1997, and the International Monetary Fund helped Korea at that time. The major reason was that important economic data, so-called Foreign Exchange Stock (FES) had not been well taken care of. Had the collection of FES, trend analysis of FES, and prediction of FES been well performed by good DT, there would not have been an economic crisis.

*Inherent political dispute in politics:*

Politics is perhaps the most underdeveloped area in Asia including Korea. Non-productive political disputes hamper development of all other areas such as industry, education, culture and so on. If people's opinion surveys are properly conducted by DT, and political parties just follow the opinion of the majority of people, politics can become more mature, and can assist all the other areas to become more developed.

*Big quality cost:*

The quality costs of most companies in Asia including Korea make up about 20% of the total sales value. The quality costs consist of P-cost for prevention, A-cost for appraisal and F-cost for failure. The ratios of these costs are roughly 1%, 3%, and 16% for P-cost, A-cost, and F-cost, respectively. If DT is well utilized for the data analysis of quality cost, the quality cost can be reduced to about 10% of total sales value. Perhaps the optimal ratios of these costs would be 3%, 2%, and 5% for P-cost, A-cost, and F-cost, respectively. Actually, Six Sigma project teams are very much aimed at reducing quality costs.

## **6.3 Knowledge Management and Six Sigma**

### *(1) Knowledge-based Six Sigma*

We think that Knowledge Management (KM) is very important in this knowledge-based information society. If Six Sigma and KM are combined, it could become a very powerful management strategy. We want to propose the so-called Knowledge Based Six Sigma (KBSS) as the combination of Six Sigma and KM.

KBSS can be defined as “a company-wide management strategy whose goal is to achieve process quality innovation corresponding to  $6\sigma$  level and customer satisfaction through such activities as systematic generation/storage/dissemination of knowledge by utilizing the information technology of the Internet/intranet, data-bases and other devices.” As shown in

Figure 6.4, there are some differences between Six Sigma and KM. However, there also exist some areas of intersections such as data acquisition and utilization, data analysis, generation of information, and so on.

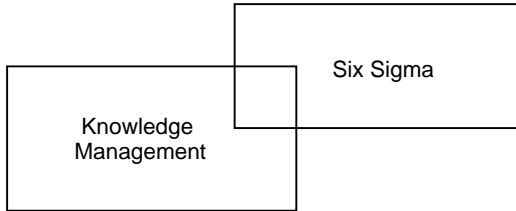

**Figure 6.4.** Knowledge-based Six Sigma

KBSS is a combination of KM and Six Sigma which can be developed as a new paradigm for management strategy in this digital society of the 21st century.

**(2) Methodologies in KBSS**

Process flow of improvement activities

In KM, it was proposed by Park (1999) that a good process flow of improvement activities is the CSUE cycle as shown in Figure 6.5. CSUE means Creating & Capturing, Storing & Sharing, Utilization and Evaluation. As explained previously, the well-known process flow of improvement activities in Six Sigma is MAIC.

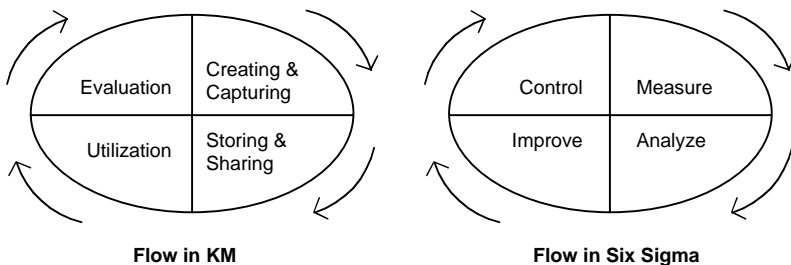

**Figure 6.5.** Process flow of improvement activities in KM and Six Sigma

The CSUE and MAIC cycles can be intermixed in order to create an efficient cycle in KBSS. One way is to use the MAIC cycle in each step of CSUE, or to use the CSUE cycle in each step of the MAIC cycle. We believe that CSUE and MAIC are both complementary to each other.

### *Project team activities*

The project team activities by BBs and GBs for quality and productivity improvement are perhaps most important activities in Six Sigma. If the concept of KM is added to these activities, more useful and profitable results could be made possible. We may call such activities KBSS project team activities. Through team efforts, we can create and capture information, store and share the information, and utilize it in the MAIC process. Also by using the MAIC process, we can create new information and follow the CSUE process.

### *Education and training*

Education and training is the most fundamental infrastructure in Six Sigma. A systematic training program for GB, BB, MBB and Champion levels is essential for the success of Six Sigma. Also in KM, without proper training, creation/storage/sharing/utilization would not be easy, and the process flow of knowledge would not be possible. It is often mentioned that the optimal education and training time in Six Sigma is about 5–7% of total working hours, and in KM it is about 6–8%. This means that more education and training time is necessary in KM than in Six Sigma. However, there is a lot of duplication in Six Sigma and KM, so the optimal education and training time in KBSS would be 8–10% of total working hours.

### *Information management*

Information on areas such as customer management, R&D, process management, quality inspection and reliability tests are essential elements in Six Sigma. In KM also, information management concerning storage, sharing and utilization of knowledge is the most important infrastructure. We believe that information management is essential in KBSS.

### Scientific tools

Basic QC and statistical tools such as 7 QC tools, process flowcharts, quality function deployment, hypothesis testing, regression and design of experiments can be used in KBSS. Also some advanced Six Sigma tools such as FMEA, benchmarking and marketing surveys can be effectively used in KBSS. These tools are helpful in analyzing data, obtaining information, statistical process evaluation and generating knowledge. We can say that KBSS is based on these scientific and statistical methods.

## **6.4 Six Sigma for e-business**

Recently, e-business has been rapidly increasing and it is of great interest to consider Six Sigma for e-business. A suitable name that incorporates Six Sigma in e-business is “e-Sigma.” It is clear that the ultimate management concept of e-Sigma should be customer satisfaction. There are four ingredients for customer satisfaction management. They are labeled CQCD, which stand for convenience, quality, cost and delivery. To have an excellent e-Sigma system for providing convenient, high-quality, low-cost products, and accurate and speedy delivery, the following e-Sigma model should be established in e-business companies.

The voice of customer (VOC) should be input into DFSS by using QFD, which converts VOC to technical requirements. These technical requirements are reflected in design aspects for Six Sigma. An ERP scheme which is suitable for e-business should be employed to manage necessary resources. Also an efficient SCM is required for systematic acquisition, handling, storage and transportation of products. In all processes of an e-business, the sigma level of each process should be evaluated and improved to assure high-quality performance of each process. For customer-oriented quality management, CRM is required in e-business. Eventually, such e-Sigma flow will guarantee a high-level customer satisfaction and simultaneous creation of new customers.



- Step 4: Measure current process performance.
- Step 5: Improve process performance.
- Step 6: Design/redesign process if necessary.
- Step 7: Expand and integrate the Six Sigma system.

***Step 1: Set up the long-term vision of Six Sigma***

Setting up the long-term vision over a period of about 10 years for Six Sigma is important for Six Sigma implementation. Without this vision, the Six Sigma roadmap may be designed in a non-productive way. For this vision, the CEO should be involved, and he should lead the Six Sigma implementation.

***Step 2: Identify core processes and key customers***

The following are the three main activities associated this step.

- Identify the major core processes of your business.
- Define the key outputs of these core processes, and the key customers they serve.
- Create a high-level map of your core or strategic processes.

In identifying the core processes, the following questions can help you to determine them.

- What are the major processes through which we provide value – products and services – to customers?
- What are the primary critical processes in which there are strong customer requirements?

In defining the key customers, we should consider the core process outputs. These outputs are delivered to internal or external customers. Very often the primary customers of many core processes could be the next internal processes in a business. However, the final evaluation of our products or services depends on the external customers.

### ***Step 3: Define customer requirements and key process variables***

The sub-steps for defining customer requirements usually consist of the following:

- Gather customer data, and develop “Voice of the customer (VOC)”;
- Develop performance standards and requirements statements; and
- Analyze and prioritize customer requirements.

When the customer requirements are identified, key process variables can be identified through quality function deployment (QFD) and other necessary statistical tools.

### ***Step 4: Measure current process performance***

For measuring current process performance, it is necessary to plan and execute the measures of performance against the customer requirements. Then it is also necessary to develop the baseline defect measures and identify the improvement opportunities. For these activities, we need to obtain:

- Data to assess current performance of processes against customers’ output and/or service requirements.
- Valid measures derived from the data that identify relative strengths and weaknesses in and between processes. Yield, rolled throughput yield (RTY), DPMO, DPU, COPQ or sigma quality level is often used for such valid measures.

### ***Step 5: Improve process performance***

The project team activity to prioritize, analyze and implement improvements is perhaps the essence of Six Sigma. Improvement efforts usually follow the DMAIC, IDOV or DMARIC process flows which were explained before. The important activities at this step are as follows.

- Select improvement projects and develop project rationale.
- Analyze, develop and implement root cause-focused solutions.

***Step 6: Design/redesign process and maintain the results***

Very often it is necessary to design or redesign the process for innovation purposes.

If such design/redesign is implemented, maintaining and controlling the altered process in good shape is desirable. The important activities at this step are as follows:

- Design/redesign and implement effective new work process.
- Maintain and control the new process in good shape.

***Step 7: Expand and integrate the Six Sigma system***

The final step is to sustain the improvement efforts, and to build all concepts and methods of Six Sigma into an ongoing and cross-functional management approach. The key idea is to expand and integrate the Six Sigma system into a stable and long-term management system. Continuous improvement is a key link in the business management system of Six Sigma. The key actions for this purpose are as follows:

- Implement ongoing measures and actions to sustain improvement;
- Define responsibility for process ownership and management; and,
- Execute careful monitoring of process and drive on toward Six Sigma performance gains.

## 7. Practical Questions in Implementing Six Sigma

---

### 7.1 Is Six Sigma Right for Us Now?

#### (1) *Key questions to answer*

Many commercial firms are wondering whether Six Sigma is right for them now. Embarking on a Six Sigma initiative begins with a decision to change – specifically, to learn and adopt methods that can boost the performance of your organization. The starting point in gearing up for Six Sigma is to verify that an organization is ready to – or needs to – embrace a big change. There are several essential questions and facts an organization has to consider in making its readiness assessment:

1. Is change a critical business need now, based on bottom-line, cultural, or competitive needs?
2. Can we come up with a strong strategic rationale for applying Six Sigma to our business?
3. Will our existing improvement systems and methods be capable of achieving the degree of change needed to keep us a successful, competitive organization?

If the answers are “Yes,” “Yes,” and “No,” an organization may well be ready to explore further how to adopt Six Sigma in its organization. However, if an organization is in one or more of the following situations, it probably would be best to say “No thanks for now” to Six Sigma adoption:

1. The organization already has a strong, effective performance and process improvement effort;
2. Recent changes are already overwhelming employees and resources; and,
3. The potential gains are not expected to be much.

## *(2) Cost/benefit perspective*

Without investment, we cannot expect a big change or a big gain. Some of the most important Six Sigma investment budget items include the following:

- Direct payroll: Individuals dedicated to the effort full-time such as BBs.
- Indirect payroll: The time devoted by executives, team members, process owners, and others to such activities as measurement, data gathering for VOC (voice of customer), and improvement projects.
- Training and consulting: Teaching people Six Sigma skills and obtaining advice on how to make the effort successful.
- Improvement implementation costs: Expenses related to installation of new solutions or process designs proposed by project teams.
- Other expenses such as travel and lodging, facilities for training, and meeting space for teams.

Estimating potential benefits is not an easy task. There is no way to accurately estimate the gains without examining the improvement opportunities present in the business, and without planning the implementation to see what the relative payoff will be. However, the following benefits could be expected:

- The total quality costs (prevention cost, appraisal cost and failure cost) can be reduced. Eventually, the costs of poor quality (COPQ) can be reduced substantially, and the company's profits can soar.
- By improving quality and productivity through process evaluations and project team efforts, the total sales and profits can dramatically increase.
- Through a sound Six Sigma initiative, better strategic management, more systematic data collection and analysis, and efforts directed toward customer satisfaction will result in a better market image and customer loyalty.

- As a result of systematic education through belt systems, cultivation and efficient utilization of manpower becomes possible, which eventually fosters employee pride in their company.

Based on the responses to key questions and the cost/benefit analysis, a company can decide whether it should take the Six Sigma initiative now or later. One important point to be kept in mind when a company prepares to embark on Six Sigma efforts is that the company should factor at least six to 12 months for the first wave of DMAIC projects to be completed and concrete results to be realized. The company can push teams for faster results. Giving them extra help or coaching as they work through their “learning curve” can be a good way to accelerate their efforts, although it may also boost your costs. It would be a mistake to forecast achievement of big tangible gains sooner than a period of six months. The company must have patience and make consistent efforts at the embarkation stage.

## **7.2 How Should We Initiate Our Efforts for Six Sigma?**

When a company decides to start a Six Sigma initiative, the first important issue to resolve is “How and where should we embark on our efforts for Six Sigma?” Since Six Sigma is basically a top-down approach, the first action needed is a declaration of commitment of top-level management. For making the management decisions, it is best to look at the criteria impacting the scale and urgency of their efforts which will strengthen the company by removing the weaknesses. Based on these facts, he should decide his Objective, Scope and Time-frame for Six Sigma engagement.

### ***(1) Determination of Objective***

Every business desires “good results” from a Six Sigma effort, but the type of results and the magnitude of the changes may vary a great deal. For example, Six Sigma may be attractive as a means to solve nagging problems associated

with product failures or gaps in customer service, or as a way to create a responsive management culture for future growth. Each of these objectives could lead to different types of Six Sigma efforts. It is possible to define three broad levels of Objectives: Management innovation, Statistical measurement and process evaluation, and Strategic improvement by problem solving (see Table 7.1).

**Table 7.1.** Three levels of Six Sigma Objectives

Objective	Description
<b>Management innovation</b>	A major shift in how the organization works through cultural change. <ul style="list-style-type: none"> <li>• Creating customer-focused management</li> <li>• Abandoning old structures or ways of doing business</li> <li>• Creating a top-level world-beating quality company</li> </ul>
<b>Statistical measurement and process evaluation</b>	All processes are statistically measured, and the sigma quality levels are evaluated. <ul style="list-style-type: none"> <li>• The sigma quality level of each process is evaluated.</li> <li>• Poor processes are designated for improvement.</li> <li>• A good system of statistical process control is recommended for each process.</li> </ul>
<b>Quality and productivity improvement by problem solving</b>	Key strategic and operational weaknesses and opportunities become the targets for improvement. <ul style="list-style-type: none"> <li>• Speeding up product development</li> <li>• Enhancing supply chain efficiencies or e-commerce capabilities</li> <li>• Shortening processing/cycle time</li> <li>• Project team efforts for key quality and productivity problems</li> </ul>

*(2) Assessing the feasibility scope*

What segments of the organization can or should be involved in the initial Six Sigma efforts? Scope is very important in the initial stage of Six Sigma. Usually we divide the whole company into three segments; the R&D part, manufacturing part, and transactional (or non-manufacturing) part. Mostly the manufacturing section is the target for initial Six Sigma efforts. However, the author is aware of some companies in Korea that began their efforts from the transactional section. It would be desirable to consider the following three factors in determining the scope of the initial Six Sigma efforts.

- Resources: Who are the best candidates to participate in the effort? How much time can people spend on

Six Sigma efforts? What budget can be devoted to the start-up?

- Attention: Can the business focus on start-up efforts? Are they willing to listen to new ideas for management innovation?
- Acceptance: If people in a certain area (function, business unit, division, etc.) are likely to resist, for whatever reasons, it may be best to involve them later. It is wise to start from the section which accepts the new Six Sigma efforts.

### *(3) Defining time-frame*

How long are you willing to wait to get results? A long lead-time for a payoff can be frustrating. The time factor has the strongest influence on most Six Sigma start-up efforts. The top management should define the time-frame for Six Sigma implementation.

## **7.3 Does Six Sigma Apply Well to Service Industries?**

Many service industries such as banking, insurance, postal office and public administration often ask “Does Six Sigma apply well to service industries?” Despite the successful application of Six Sigma in companies such as AIG Insurance, American Express, Citibank, GE Capital Services, NBC and the US Postal Service, executives and managers from the service industry very often wonder if Six Sigma is applicable to their type of business.

The primary response to this question is that Six Sigma has the potential to be successful in almost any industry. Since Six Sigma mainly focuses on customer satisfaction, variation reduction, quality improvement and reduction of COPQ, the results enjoyed by Six Sigma companies in the service industry are just as impressive as their counterparts in the manufacturing industries.

Let’s take the example of GE Capital Services. Three years after the launch of Six Sigma (1995 was the beginning year),

they reported: “In 1998, GE Capital generated over a third of a billion dollars in net income from Six Sigma quality improvements – double that of 1997. Some 48,000 of our associates have already been extensively trained in this complex process improvement methodology – and they have completed more than 28,000 projects.”

The framework in Six Sigma for ensuring and measuring that customer requirements are met should also be attractive to most service organizations. In Six Sigma, the customers are asked to identify the critical characteristics of the services they consume and what constitutes a defect for each of the individual characteristics. Based on these, the Six Sigma measuring system is built up.

It is true that many service companies often find it difficult to measure their processes adequately. Compared to manufacturing processes, it is often more demanding to find appropriate characteristics to measure. Also it is difficult to measure the sigma quality level for a service process. In this case, a possible way to set up the quality level for a service process is as follows.

6 $\sigma$ level	<ul style="list-style-type: none"><li>• the ideal level to be reached or</li><li>• the benchmark level of the best company in the world</li></ul>
3 $\sigma$ level	<ul style="list-style-type: none"><li>• the current level of my company</li></ul>

According to the above levels, the company can achieve the levels of 4 $\sigma$  and 5 $\sigma$ . If the current level of the company is very poor, one can designate the company level as 2 $\sigma$ .

## 7.4 What is a Good Black Belt Course?

### (1) *A Black Belt course*

Depending upon each company, the content and duration of a Black Belt course could be different. Most Korean companies take four five-day sessions and one final graduation

day. The duration is usually four months; one week for one session and three weeks for the practice period in each month. Hence, it takes four months. Usually a project is carried out during the four-month period, and a certified examination is conducted before graduation. Also a homework assignment is given after each session. On the final graduation day, the project is presented and the Black Belt certification is awarded. The following are the major contents of the four sessions.

**First Session (focus on Define & Measure in DMAIC):**

- Introduction to Six Sigma: The history, definition, philosophy and major strategies of Six Sigma
- Basic statistics: Basic descriptive statistics, PPM, DPMO, DPO, DPU, continuous data, normal distribution, Z-transform
- The 7 QC tools
- Six Sigma statistics: Sigma quality level, process capability, rolled throughput yield, attribute data, Poisson and binomial distributions
- Advanced statistics: Concept of statistical estimation and hypothesis testing, t-test, confidence interval, F-test, case studies and exercises
- Correlation and regression analysis: Theories and case studies
- Benchmarking
- Costs of poor quality (COPQ): Quality costs, hidden factory.
- Long-term quality management: Measure process performance and case studies.
- Homework (or project) assignment (between first and second session): Several homework exercises can be assigned to make use of the above methodologies. For example:
  1. Select a process with a chronic problem which has been awaiting a solution for a long time where a certain economic advantage is to be gained by improvement. Run a project, first using the 7 QC tools and show an economic advantage.

2. Measure process performance of at least three different characteristics and compute the sigma quality level for each one and the combination of the three characteristics.
3. Run a regression analysis for a process, find significant factors and suggest improvements with a cost reduction potential.

**Second Session (focus on Analyze in DMAIC):**

- Review of homework assignment
- Understanding variation, quality and cycle time
- Process management: Principles and process flowcharts
- Measurement evaluation analysis
- Introduction to design of experiments (DOE): Full factorial design and fractional factorial design
- DOE, introduction and software: Exercises with Minitab, JMP and others
- Quality function deployment (QFD)
- Reliability analysis: FMEA (failure mode and effects analysis)
- Homework assignment (between second and third session):
  1. Find a process where a certain economic advantage is to be gained by improvement. Run a full factorial with two or three factors.
  2. Collect VOCs (voice of customers) and, using QFD, find CTQs which you should handle in your process.

**Third Session (focus on Improve in DMAIC):**

- Review of homework assignments
- DOE: ANOVA, p-value, Robust design (parameter design, tolerance design)
- Response surface design: Central composite designs, mixture designs
- Gauge R&R test
- Six Sigma deployment
- Six Sigma in non-manufacturing processes: Transactional Six Sigma methodologies
- Homework assignment (between third and fourth session):

Select a process with a chronic problem in CTQ deployment. Screen important factors by regression analysis, optimize the process by using a robust design or a response surface design.

**Fourth Session (focus on Control in DMAIC):**

- Review of homework assignments
- Control charts
- Statistical process control
- DFSS (design for Six Sigma)
- Black Belt roles: Job description of BBs
- Six Sigma and other management strategies: The relationship of Six Sigma to ISO 9000, TQC, TQM, ERP, and other management strategies
- Six Sigma in a global perspective
- Group work (evening program): Why is Six Sigma necessary for our company?
- Homework assignment (between fourth session and graduation): Take a project where the economic potential is at least \$50,000 in annual cost reduction and complete the project

**Graduation**

- Review of homework assignments
- BB certified test
- Presentation of the projects completed
- Graduation ceremony

***(2) Job description of a BB***

The role of a BB is very critical for the success of Six Sigma. The job description of a BB could be different from company to company, but the following is a general guideline for job the description of a BB:

- Lead a project improvement team, and also lead a focused effort to systematically assess the performance of our business systems and processes (measure DPMO)

- Apply the Six Sigma skills and tools to analyze inadequate processes and recommend solutions for improvement
- Communicate the plans, methods and the results achieved in a documented fashion in regularly scheduled meetings
- Provide training and consultation to local personnel in Six Sigma strategies and tools

### **7.5 What are the Keys for Six Sigma Success?**

From the author's consulting experience for Six Sigma, it is believed that the following points are the keys for a Six Sigma success. The points could be slightly different depending on the type of business of your company. However, the general ideas remain applicable to all types of businesses.

***(1) Get the top managers involved.***

Until senior managers of the corporation or business unit really accept Six Sigma as part of their jobs and as the company's management strategy, the true importance of the initiative will be in doubt and the energy behind it will be weakened.

***(2) Keep the message simple and clear, and request the participation of all employees.***

Since Six Sigma is a new management strategy, the core of the system and your company's vision for Six Sigma should be simple, clear, meaningful and accessible to everyone. While new vocabulary and skills are obviously part of the Six Sigma discipline, beware of the possibility of alienating some people by the strange terms and jargon that could create "classes" in a Six Sigma environment. Participation of all employees in the Six Sigma efforts is essential for a Six Sigma success.

**(3) *Select the right Six Sigma projects and train an adequate number of full-time BBs to concentrate on project team efforts.***

Project selection is perhaps the most critical activity in launching a Six Sigma project. Well-selected and well-defined improvement projects equal better and faster results. In selecting project themes, a top-down approach based on the company's CTQ deployment is often used. In running the project teams, it is recommended that the BBs become the full-time leaders who can concentrate their entire efforts to the team project for a success.

**(4) *Focus on short-term results and long-term growth.***

It is very stimulating to have initial achievements in the first four to six months. Hence, focusing on short-term results at the beginning is a good strategy. However, it is also important to balance the push for short-term results with the recognition that those gains must lay the foundation for the real power of Six Sigma. Creation of a more responsive, customer-focused, and successful company for the long-term is the major source of Six Sigma success.

**(5) *Publicize and award results, and admit setbacks.***

Recognize and celebrate successes, but pay equal attention to challenges and disappointments. Don't expect that Six Sigma will work perfectly in your company. Be ready to continuously improve and even redesign your Six Sigma processes as you progress.

**(6) *Develop your own style toward Six Sigma.***

Your themes, priorities, projects, training, structure – all should be decided based on what works best for you. Develop your own style toward Six Sigma based on your company's culture and habits, if there are any. Setting up a "Six Sigma Day" each month to evaluate the progress of Six Sigma, and to publicize and reward results is a good idea, if your company's culture suits this.

**(7) *Link customers and your processes.***

Customer satisfaction is one of the core elements of the Six Sigma approach. To ensure customer satisfaction, there must be a way to link customers and your processes efficiently to build an excellent Six Sigma system.

**(8) *Make learning an ongoing activity, and make an investment to make it happen.***

A few months of training, however intensive, won't cement all the new knowledge and skills needed to sustain Six Sigma. Making learning a continuous and ongoing activity is necessary. Without time, support and money, the habits and existing processes in your business won't change much. You have to make an investment to make it happen.

**(9) *Use Six Sigma tools wisely.***

There are many tools available in Six Sigma. However, very often, no single tool can create happier customers or improve profits. Statistics can answer questions, but can't solve all possible problems. Your success with Six Sigma will depend on applying all the methods wisely, in the right balance, to maximize your results. In general, using the simplest tool that works – not the most complex – should be highly valued.

## **7.6 What is the Main Criticism of Six Sigma?**

Since Six Sigma itself is only 15 years old, and its historical development has been one of dynamic changes, there are some criticisms on Six Sigma. The major criticisms are as follows.

**(1) *Six Sigma is nothing new. It is just old tools in new clothing.***

Critics of Six Sigma have often said that it contains nothing new. The proponents acknowledge that the tools applied in Six sigma are not new – they are proven statistical tools. However, Six Sigma is new in many aspects. It has provided a

powerful corporate framework for these tools to become effective and enabled the important link between the bottom line and top line. The following points which differentiate Six Sigma from earlier attempts can be highlighted:

- Its strategic involvement of top management in the companywide improvement process
- Its customer focus
- Its focus on project team efforts and financial results
- Its focus on education and training through belt systems
- Its formalized improvement methodology, such as DMAIC, IDOV, etc.

***(2) The expected benefits are unrealistic.***

A criticism is that publicized expected results are unrealistic. This criticism is rejected by annual reports from many Six Sigma companies. GE alone achieved Six Sigma benefits of about \$1.2 billion on a \$450 million investment in 1998, for 1999 the savings were in the plus \$2 billion range. ABB, Motorola, Samsung SDI, LG and others report that Six Sigma is delivering what is promised.

***(3) Other business improvement initiatives will soon replace Six Sigma. It is just another fad.***

The argument that other strategic initiatives will replace Six Sigma is not very controversial and applies to all strategic initiatives in the business world, be they widely deployed or not. Some argue that Six Sigma will disappear soon from corporate agendas, which means that it is a fad.

We believe that Six Sigma is more than just a fad. The Six Sigma concept has survived for more than a decade already and is way beyond the point where it could become a management fad lasting just a few years. One reason could be that Six Sigma was developed by the industry and for the industry – with a deployment based on merit. Another reason could be that Six Sigma is a more systematic, pragmatic, statistical and smarter approach compared to other past initiatives.

***(4) Key Six Sigma practices are based on faulty statistical assumptions.***

Some of the assumptions often employed in Six Sigma practices are said to be faulty by many opponents. Most criticized are assumptions relating to:

- The Normality assumptions
- The acceptance of a  $\pm 1.5\sigma$  long-term shift
- Predictability of the future outcome

A common answer to these concerns is that the assumptions are made for pragmatic reasons to make matters simple and easily understood by all in the company. Even though the Normal distribution assumption may not always be completely correct, the procedures based on the Normal distribution assumption are often very robust, i.e., the consequences in terms of the errors are almost negligible.

The use of the  $1.5\sigma$  shift is criticized for being unrealistic and without a foothold in reality. Of course there is no natural law telling us that all processes have this much long-term shift in average value. However, each process has its own variations arising from several sources, and it can be assumed that the sum of all acceptable sources of variation may add up to  $1.5\sigma$ . In industrial practice, this has been confirmed to be reasonable. Of course, it would be possible to utilize for each process its own special long-term shift; however, that would not have been very practical. A pragmatic approach is to use the  $1.5\sigma$  shift of the process average in either direction.

## 8. Case Studies of Six Sigma Improvement Projects

---

Three companies have generously let us use one of their internal cases on improvements projects, applying the Six Sigma methodology. The first case was an improvement project on the production process for microwave ovens at LG Electronics in Korea, which used the classical Six Sigma methodology, DMAIC. The process performance was insufficient due to poor centering of the characteristic studied. It was a typical manufacturing application.

The second case was an improvement project on the reduction of short shelf-life material at Korea Heavy Industries & Construction Company. This was a typical non-manufacturing application which developed an efficient computerized control system and which uses the DMARIC process. The third case was an R&D project on design optimization of the inner shield of the Omega color picture tube at Samsung SDI in Korea. This was a typical R&D project which basically used the IDOV process.

### 8.1 Manufacturing Applications: Microwave Oven Leakage

LG Electronics is one of the largest affiliates of the Korea-based LG Group, with 52 branches, 25 sales subsidiaries, and 23 manufacturing subsidiaries spanning 171 countries throughout the world. The whole LG Group applies Six Sigma. This was a Six Sigma improvement project on microwave ovens by Digital Appliance. This case was also reported by Magnusson, Kroslid and Bergman (2000).

#### (1) *Define*

The doors of microwave ovens are a long-standing problem for producers around the world, mainly due to leakage (see Figure 8.1). This affects not only the performance of the oven,

but can also lead to damage to the oven itself during use. The leakage specification is 0.5mW. The Digital Appliance section decided to apply the Six Sigma improvement methodology to the leakage problem in the doors. The general DPMO level for the door was at 750 at the time of defining the project.

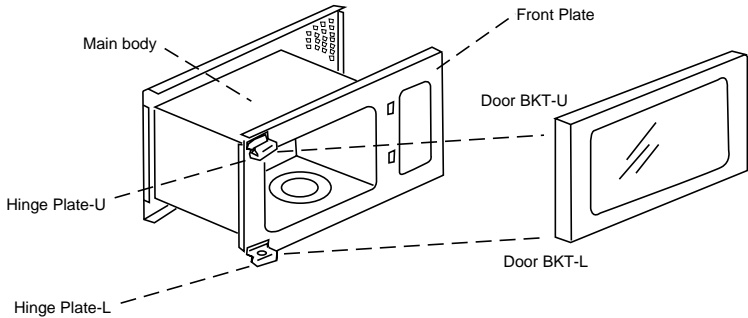

Figure 8.1

A cause-and-effect diagram of the relevant information on characteristics in the measurement system pointed to three main causes for the door leakage; namely the distortions on the frame slit (381 DPMO), distortions on the door hinge pin (250 DPMO) and defects in the height of the piercing hole on the hinge plate (1,100 DPMO) (see Figure 8.2). It was decided by the team to make the piercing hole height on the hinge plate to be the result variable,  $y$ , of the improvement project.

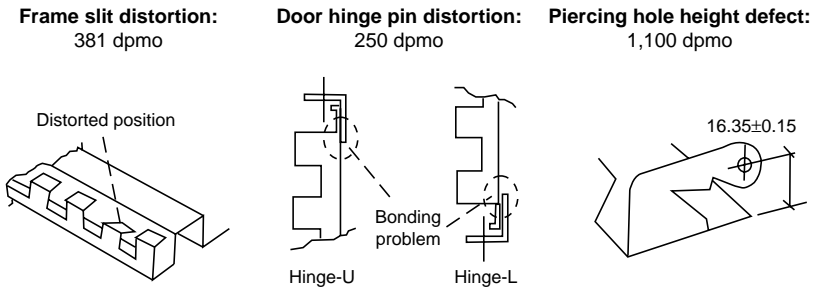

Figure 8.2. The three main causes of leakage

(2) Measure

The holes are pierced in the process of making the hinge plates. This process starts with the notching of the plates, then the piercing of holes on both the upper and the lower hinge, followed by bending, embossing and cutting. The hinge plate is then welded onto the main body of the microwave oven (see Figures 8.3 and 8.4).

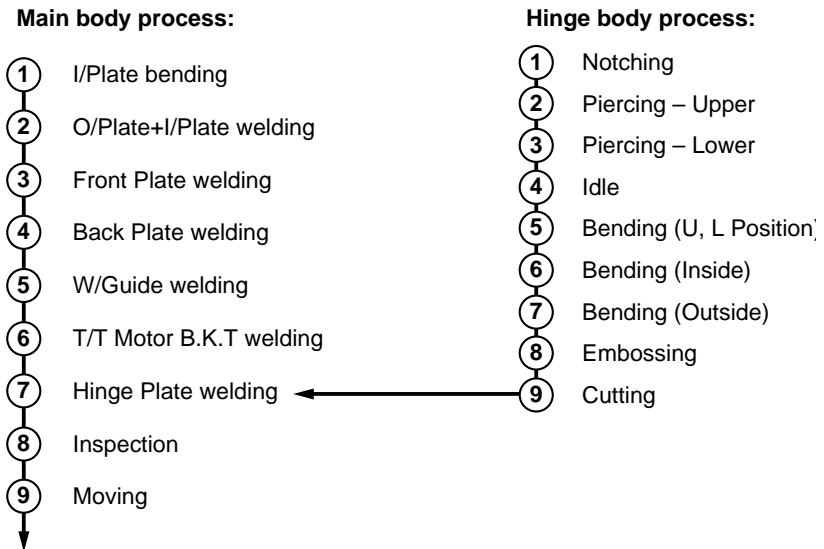

Figure 8.3. Flowchart of process for manufacture of hinge plates

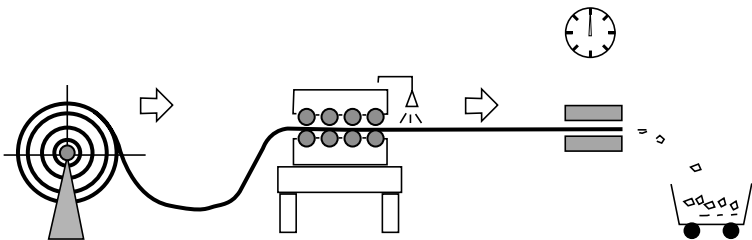
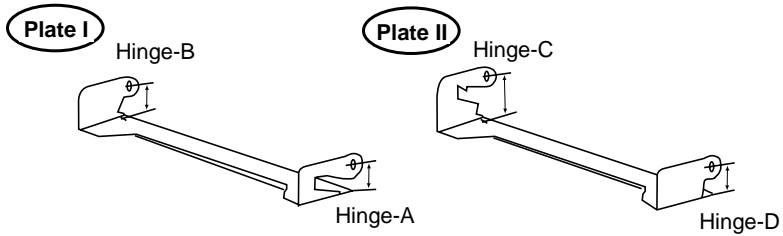

Figure 8.4. Sketch of hinge plate process

For the height of the piercing hole, the target value was 16.35mm, the upper specification limit was set at 16.50mm and the lower specification limit at 16.20mm. Two different types of hinge plates (Plate I and Plate II) were tested (see Figure 8.5).



**Figure 8.5.** The two hinge plate types with piercing hole height

Detailed measurements for the two plate types, each with two hinges, were made over some time. Forty-nine plates of type I were measured as well as 49 plates of type II.

### (3) Analyze

The analysis of the data measured showed (Table 8.1) that for Plate I and Hinge-A, the entire distribution of the piercing hole heights laid below the lower specification limit.

For Hinge-D the process performance was also very poor, at 829,548 DPMO. For Hinge-B, the DPMO value was somewhat better and it was reasonable for Hinge-C. However, the dispersions were small for all hinges, implying that a centering of the process would probably give significant improvement in performance.

**Table 8.1.** Measurement results (specification is  $16.35 \pm 0.15$  mm)

Plate type	Hinge	<i>n</i>	Average	<i>s</i>	DPMO
Plate I	Hinge-A	49	15.82	0.020	1,000,000
	Hinge-B	49	16.23	0.026	124,282
Plate II	Hinge-C	49	16.31	0.038	1,898
	Hinge-D	49	16.16	0.042	829,548

To find the input variables, Xs, that influence the centering of the distribution for the piercing hole height, a cause-and-effect diagram was used. In a brain-storming session it was indicated that the materials, piercing order, and bending times were the likely influential factors for the centering of the piercing hole height (Figure 8.6).

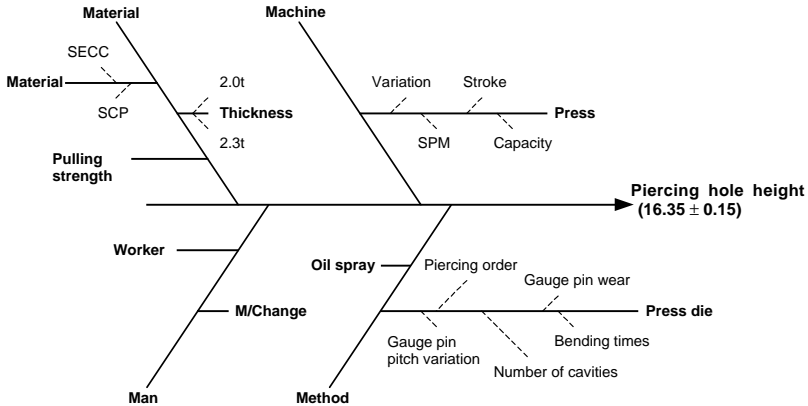

Figure 8.6. Cause-and-effect diagram for piercing hole height

(4) *Improve*

To improve the centering of the process, it was decided to apply a factorial design. The dependent variable, Y, was the height of the piercing hole, and the main factors, Xs, were set as follows for the experiment.

- A: Material; SCP (-), SECC (+)
- B: Piercing order; piercing before bending (-), and bending before piercing (+)
- C: Bending times; 2 times (-), 3 times (+)

Eight experiments of a  $2^3$  factorial design were run and the results recorded (Table 8.2). A cube plot of the results is shown in Figure 8.7, and the ANOVA (analysis of variance) table is given in Table 8.3.

**Table 8.2.** Design and results of eight experiments

Setting number	A	B	C	AB	AC	BC	Error (ABC)	Result
1	-	-	-	+	+	+	-	16.110
2	-	-	+	+	-	-	+	16.172
3	-	+	-	-	+	-	+	16.264
4	-	+	+	-	-	+	-	16.316
5	+	-	-	-	-	+	+	16.109
6	+	-	+	-	+	-	-	16.230
7	+	+	-	+	-	-	-	16.251
8	+	+	+	+	+	+	+	16.327
<b>Effect</b>	0.014	0.134	0.078	-0.015	0.021	-0.014	-0.009	y = 16.222
<b>Sum of squares (<math>\times 10^5</math>)</b>	2.45	224.45	76.05	2.81	5.51	2.45	1.01	

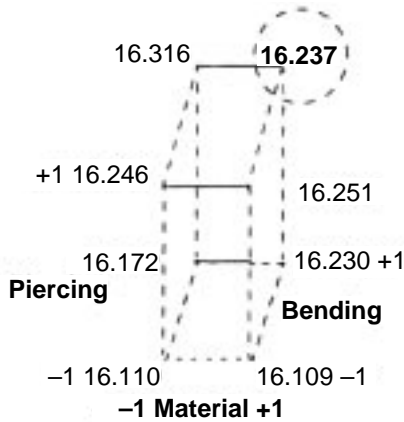

**Figure 8.7.** A cube plot of the results

**Table 8.3.** ANOVA table of the results

Sources	Sum of squares ( $\times 10^5$ )	Degrees of freedom	Mean square	F
A	2.45	1	2.45	2.43
B	224.45	1	224.45	222.23
C	76.05	1	76.05	75.30
AxB	2.81	1	2.81	2.78
AxC	5.51	1	5.51	5.46
BxC	2.45	1	2.45	2.43
Error	1.01	1		
Total	313.72	7		

The analysis of the effects showed that factor B (piercing condition) and factor C (bending times) were the significant factors.

In building a prediction model for the height of the piercing hole, factor B and factor C were both set at high levels to obtain a centered process. This was based on the fact that the average value of all the eight experiments was 16.222, a lower value than the target value of the process, 16.350. This gave a very good prediction model for the process, with an estimated mean value of 16.328.

Factor B was then set at a high level, i.e. bending before piercing, and factor C at a high level, i.e., 3 times bending. Factor A, which was non-active, was set at the high level, as SECC was the cheapest material. By doing so, the distributions for the heights of all four hinges would be much better centered, and the process performance for both types of plates significantly improved (Table 8.4).

**Table 8.4.** The nominal value of height for all four hinges

	Hinge-A	Hinge-B	Hinge-C	Hinge-D
<b>Before (mm)</b>	15.82	16.23	16.31	16.16
<b>After (mm)</b>	16.33	16.33	16.36	16.29

*(5) Control*

The improvement was then verified by use of control charts for the average and range (Figure 8.8). Considerable cost savings were also reported and recognized by the top management of the company.

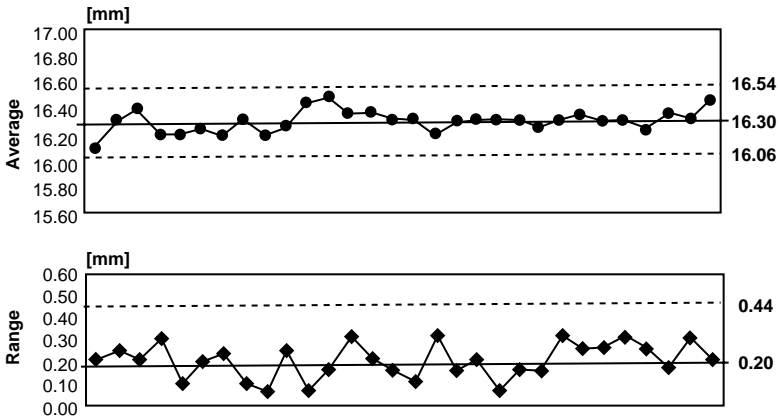

**Figure 8.8.** Control charts showing the improvement in Y, the piercing hole height

## 8.2 Non-manufacturing Applications: Development of an Efficient Computerized Control System

Korea Heavy Industries & Construction Company (which changed its name to Doosan Heavy Industries Company in 2001) learned Six Sigma management skills from General Electric in 1997, and started Six Sigma to achieve management innovation. In early 2000, the company published a book called “Six Sigma Best Practices” in which 15 Six Sigma project activities are contained. The long-term vision of the company is to become a “Competitive world-class company of 21st century with the best quality and technology.” To achieve this vision, the company made its own MAP (management action plans), with which CST (critical success themes) were selected for quality and productivity innovation.

This case study presented here is one of the CSTs which is contained in the Six Sigma Best Practices. The Engineering & Technology Division of this company desired to solve one CST, namely “Reduction of Short Shelf-Life Material (SSLM).” Management formed a project team with a full-time BB and five part-time GBs to tackle this project.

(1) *Define*

There were many materials necessitating storage on a shelf for some period of time to be subsequently used to create various products. Each material had its own specified shelf life-time depending upon whether it was stored in a refrigerator or not. Some frequently used materials and their specifications are listed in Table 8.5. The shelf life-time was counted from the manufactured date.

**Table 8.5.** Stored materials and their specified shelf

Material	Storage in refrigerator		Storage in storeroom	
	Shelf life-time	Storage condition	Shelf life-time	Storage condition
Mica paper tape (#77865)	6 months	below 7°C	3 months	below 23°C
Mica paper tape (#77906)	6 months	2–10°C	3 months	18–32°C
GI yarn flat tape prepreg	1 year	below 5°C	3 months	18–32°C
Mica M tape (#77921)	6 months	2–10°C	2 months	18–32°C
Modified epoxy varnish	6 months	below 10°C	2 months	18–32°C
Polyester resin–35%	1 year	2–10°C	6 months	18–32°C
Epoxy impreg fiber cloth (#76579)	6 months	2–10°C	1 month	18–32°C
Pa–polyester sesin	10 months	2–10°C	3 months	18–32°C
Pb–catalyster	10 months	2–10°C	3 months	18–32°C
Polyester comp	1 year	2–10°C	3 months	18–32°C
Glass cloth & tape	1 year	2–10°C	3 months	below 25°C
Polyester comp	1 year	2–10°C	3 months	18–32°C
...				

However, due to poor storage conditions and other reasons, the shelf life-times became short, and they could not be used in good condition. Such SSLM resulted in some COPQ, environmental pollution and additional testing expenses.

(2) *Measure*

During the period of July – December, 1999, scrap materials were found during the process of manufacturing many products. Table 8.5 shows the scrap materials for the product, stator bar and connecting ring.

**Table 8.6.** Scrap materials in the stator bar & connecting ring

Material	Purchase quantity	Scrap			Cause of scrap			
		Quantity	Unit	Number of times	Change in manufacturing schedule	Earlier purchase	No control of storage	Etc.
Modified epoxy varnish	92	31	GL	2			2	
Epoxy impeg fiber cloth	7,890	120	SH	2	1	1		
Glass cloth & tape	958	84	RL	5	2	1	1	1
Transposition filler	4,118	55	LB	1			1	
.....								

The products/processes that were of particular concern are listed in Table 8.6 along with their current process capabilities.

**Table 8.7.** Current process capabilities

Product/process	Defect	Unit	Opportunity	Total Opportunity	DPU	DPO	DPMO	Process capability (sigma level)
Stator bar & connecting ring	61	12	50	600	5.083	0.101	101,667	2.77
Stator W'g ass'y	148	13	71	923	11.385	0.160	160,347	2.49
Lower frame A.	31	14	8	112	2.214	0.277	276,786	2.09
Rotor coil A.	4	17	5	85	0.235	0.047	47,059	3.17
<b>Total</b>	244			1,720		0.142	141,860	2.57

**Defect:** Over shelf life-time of SSLM

**Unit:** 4 items categorized in the processing using SSLM

**Opportunity:** Quantities of SSLM used in unit

**Total opportunity** = Unit × Opportunity

**DPU** = Defects/Unit

**DPO** = Defects/Total opportunity

**DPMO** = DPO/1,000,000

**Short-term capability** = Long-term capability + 1.5

### (3) Analyze

In order to discover the sources of defects and variation, a cause-and-effect diagram was sketched by the team as shown in Figure 8.9.

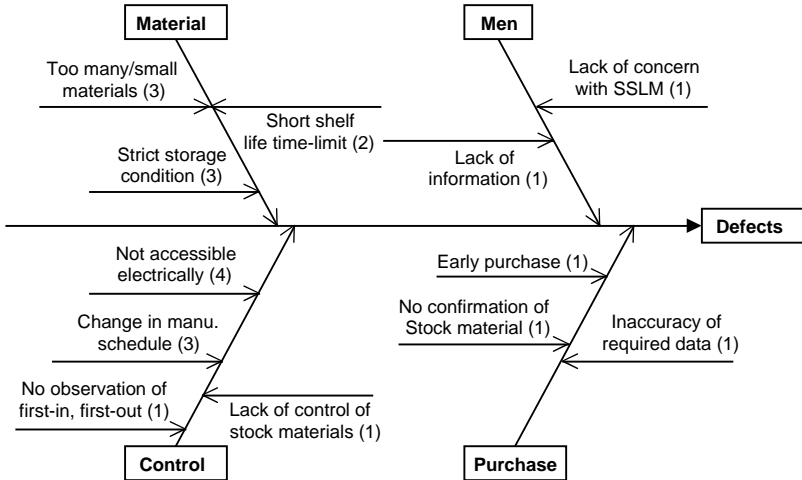

**Figure 8.9.** Cause-and-effect diagram for SSLM

In the past six-month period, the total defect count on the materials was 244, and the Pareto diagram for the types of defects is shown in Figure 8.10.

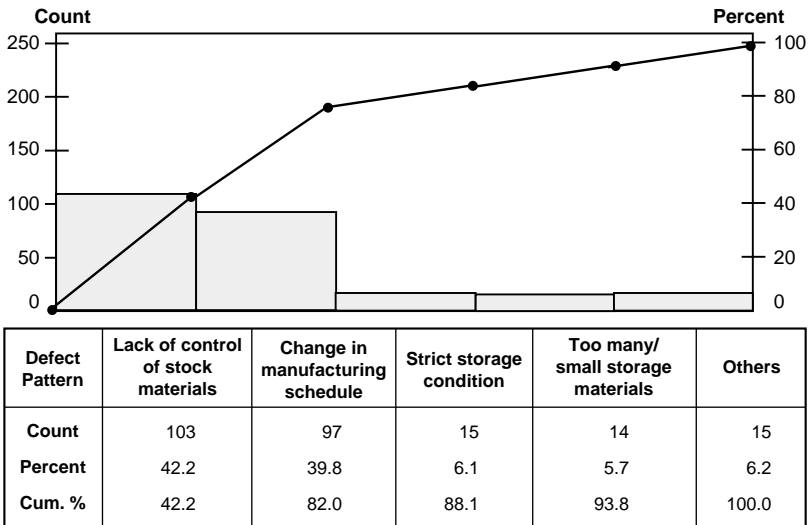
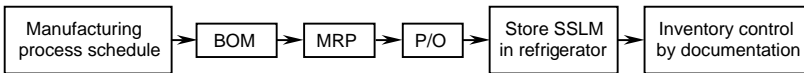

**Figure 8.10.** Pattern of defects

Figure 8.10 shows that insufficient control of SSLM in the storehouse accounted for 42.2% of the total and the unexpected changes in the manufacturing schedule were responsible for 39.8% of the total defects.

#### (4) Redesign

In order to reduce the defects of SSLM, the computerized inventory control system was redesigned to increase the control efficiency of SSLM. The current process after the redesign looks as follows.



In this current process, there is no tool for checking and monitoring SSLM, and no one is assigned for checking the defects. The redesigned and improved process (Figure 8.11) makes cross-checking of the manufacturing schedule in advance possible. Also, the related departments can monitor and control SSLMs through an on-line system.

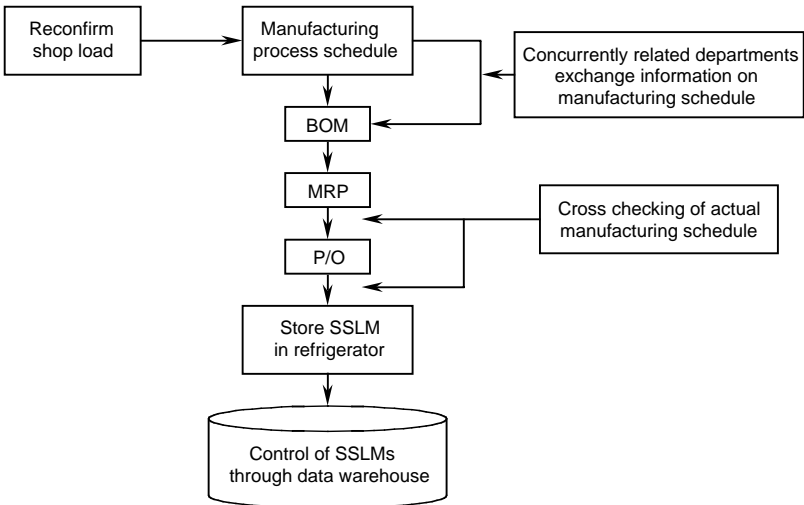

Figure 8.11. Redesigned process for SSLMs

**(5) Improve**

By practicing the improved process, they could obtain the following data for the first three months after the start of its use for SSLMs.

Product/process	Defect	Unit	Opportunity	Total opportunity	DPU	DPO	DPMO	Process capability (sigma level)
Stator bar & connecting ring	4	13	24	312	0.308	0.01282	12,820	3.73
Stator wiring assembly	3	7	45	315	0.429	0.06667	66,670	3.00
Lower frame A.	1	6	3	18	0.167	0.05556	55,560	3.09
Rotor coil A.	0	10	5	50	0	0	0	6.00 (estimated)
Total	8			695		0.01151	11,510	3.77

We can compare the quality performances of the old and newly improved processes as follows, clearly showing the impact of the Six Sigma team activities:

	Before improvement	After improvement
<b>DPMO</b>	141,860	11,510
<b>Sigma level</b>	2.57	3.77
<b>COPQ</b>	\$190,000/year	\$15,400/year (estimated)

**(6) Control**

In order to maintain the benefits, the team decided to follow the following control procedures:

- Update the SSLM instruction manual, and check the manual every six months.
- Educate the workers on SSLM information every month.
- Monitor related data through the on-line computer system every other month.

### **8.3 R&D Applications: Design Optimization of Inner Shield of Omega CPT**

CPT means color picture tube. Samsung SDI is one of the two initiators of Six Sigma in Korea. When the company applied for a National Six Sigma Quality Award In 2000, it submitted a book entitled “Six Sigma case studies for quality innovation.” This book contains the 10 most remarkable results obtained by Six Sigma project teams. One DFSS (R&D Six Sigma) case study is presented here. The team consisted of eight persons (one is a Champion, and the other seven members are all BBs). The duration of this study was from January to June of 2000. The team basically used the IDOV (Identify, Design, Optimize, Validate) process. However, it added R-D (Recognize and Define) before IDOV, hence the process of team activities is R-D-I-D-O-V. Table 8.8 shows the project implementation steps used by this team.

#### **(1) *Recognize***

The current management strategy of Samsung SDI is to have four No. 1 products in the world. In order to have the world’s best CRT, customer needs must be met. The major customer demands for a new CRT are as follows.

- slim (short back length)
- larger scale and flat
- high-quality screen performance
- HD resolution
- long life and quick start

To meet the above customer demands, it was necessary to develop a new product, called Omega CPT.

#### **(2) *Define***

The key problems to be solved for the above demands were as follows:

- Slim: The short length increases deflection angle and decreases I/S (inner shield) height. The Omega CPT is sensitive to external magnetic fields. Hence, the key issue is to minimize the influence of any external magnetic fields.

**Table 8.10.** Project implementation steps of a DFSS team

DFSS steps	Detailed steps	Tools used	Design review for product development
<b>R (Recognize)</b>	<ul style="list-style-type: none"> <li>• Analysis of CPT market trends</li> <li>• Preparation of customer value map</li> </ul>	<ul style="list-style-type: none"> <li>• Customer review</li> <li>• Business planning</li> </ul>	
<b>D (Define)</b>	<ul style="list-style-type: none"> <li>• Selection of Omega CPT CFR</li> <li>• Theme selection of CPM flow-down</li> </ul>	<ul style="list-style-type: none"> <li>• QFD, CPM</li> <li>• Concept engineering</li> </ul>	DR1
<b>I (Identify)</b>	<ul style="list-style-type: none"> <li>• Selection of project CFR</li> <li>• Failure analysis</li> <li>• Measurement analysis</li> </ul>	<ul style="list-style-type: none"> <li>• FMEA</li> <li>• MSA</li> <li>• Benchmarking &amp; gap analysis</li> </ul>	
<b>D (Design)</b>	<ul style="list-style-type: none"> <li>• List of all input variables</li> <li>• Design of basic shape and decision of prototype</li> <li>• Tolerance analysis for yield improvement</li> </ul>	<ul style="list-style-type: none"> <li>• Cause &amp; effect matrix</li> <li>• Simulation, capability study</li> <li>• Tolerance design</li> </ul>	DR2
<b>O (Optimize)</b>	<ul style="list-style-type: none"> <li>• Determination of big Xs which influence Y</li> <li>• Determination of optimal levels of big Xs</li> <li>• Quality check through pilot study</li> <li>• Completion of paper design</li> </ul>	<ul style="list-style-type: none"> <li>• DOE &amp; ANOVA</li> <li>• Robust design</li> <li>• DFM</li> </ul>	DR3
<b>V (Validate)</b>	<ul style="list-style-type: none"> <li>• Verification for mass production</li> <li>• Analysis of process capability</li> <li>• Determination of final product quality</li> </ul>	<ul style="list-style-type: none"> <li>• Process mapping</li> <li>• Capability study</li> <li>• Reliability study</li> </ul>	DR4

**Abbreviations:** CPM = Critical Parameter Method  
 QFD = Quality Function Deployment  
 CFR = Critical Functional Responses  
 FMEA = Failure Mode and Effect Analysis  
 MSA = Measurement System Analysis  
 DOE = Design of Experiments  
 ANOVA = Analysis of Variance  
 DFM = Design for Manufacturability

- High resolution: High resolution decreases spaces between stripes, which makes the pitch small. The small pitch makes the landing shift of the electron beams large. Hence, the key issue is to minimize the landing shift.

The technology relating to magnetic shields for solving the above is to consider the design of the inner shield material and inner shield shape as shown below.

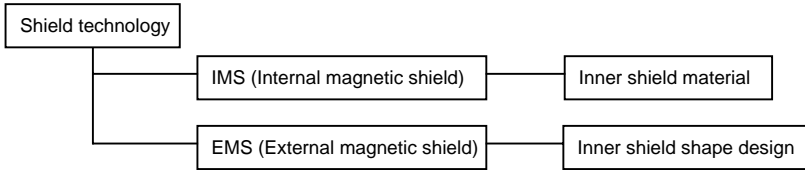

### (3) *Identify*

In order to determine the critical parameters, the following critical parameter method (CPM) was used, and the inner shield was identified as the major critical parameter.

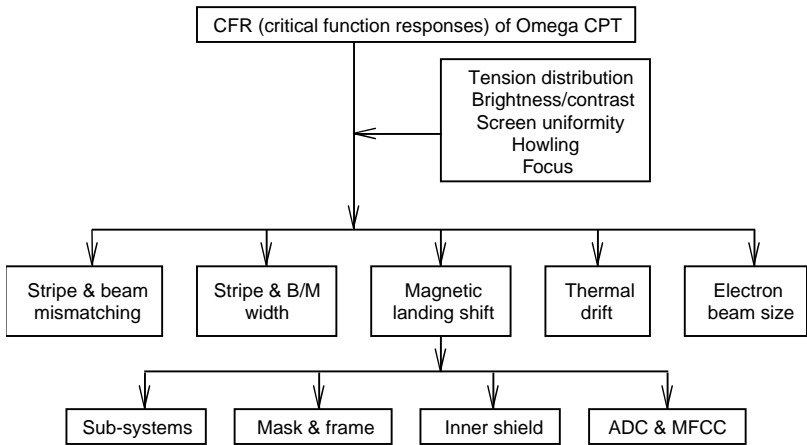

The magnetic landing shift had to be minimized. However, the landing shift was directly related to CFRs of the design of the inner shield. The goals for the magnetic landing shift were as follows:

	Magnetic shift	Yield	Sigma level
<b>Current level</b>	C	C	1.25
<b>First goal</b>	B	B	4.38
<b>Final goal</b>	A	A	6.00

(4) Design

What are the key parameters of the inner shield for minimizing the magnetic landing shift?

To determine the parameters, the flowchart of the design process (Figure 8.12a) for the inner shield was sketched.

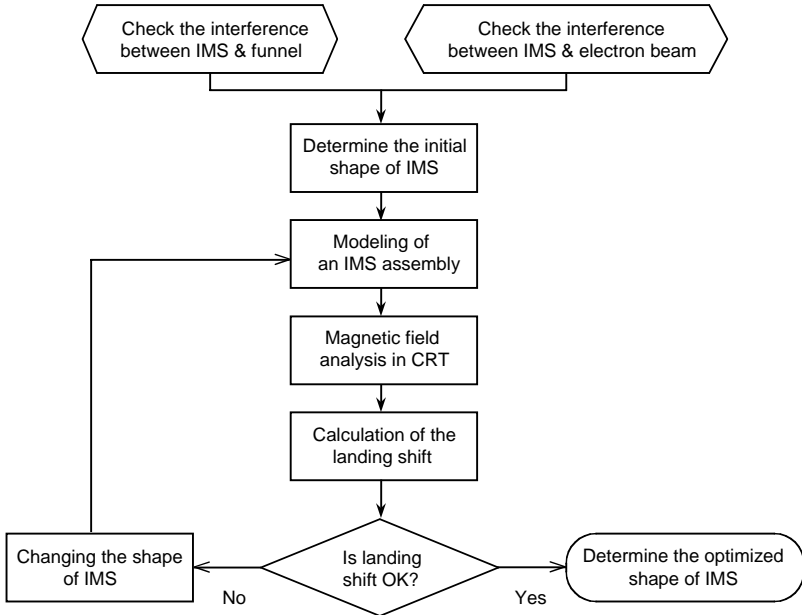
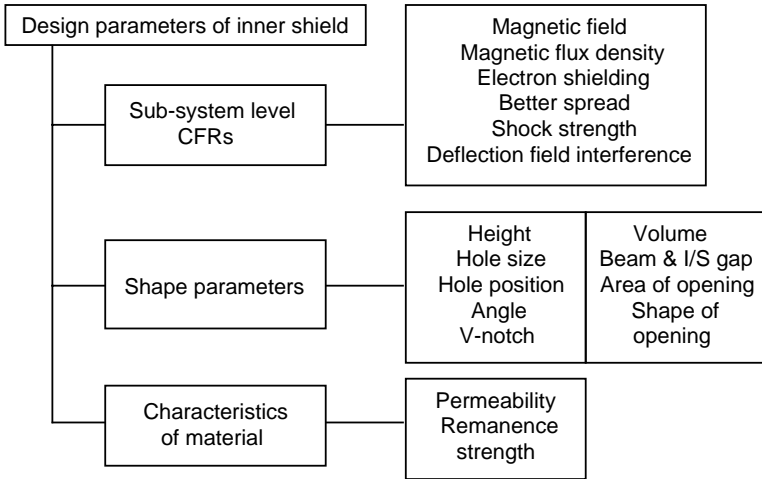

Figure 8.12a. Design process of inner shield

The design parameters of the inner shield are listed as follows according to sub-system level CFRs, shape, and material.



**Figure 8.12b.** Design parameters of inner shield

A cause-and-effect matrix and an engineering simulation study were made to select the critical parameters. As a results, four parameters (material, hole size, height, V-notch) were selected.

**(5) Optimize**

To find the optimal levels of the four key parameters select-ed, a design of experiments (DOE) was run. The levels investi-gated were as follows. The levels used originally were IV (old) for material, medium for hole size, A mm for height, and B mm for V-notch.

Factors	Number of levels	Level values
Material	2	IV (old), POS (new)
Hole size	3	large, medium, small
Height	3	A mm, B mm
V-notch	3	A mm, B mm, C mm

The total number of treatment (factor) combinations could be as many as  $2 \times 3 \times 3 \times 3 = 54$ , which is too many in practice. Hence,  $L_{18}(2^1 \times 3^7)$ , which is an orthogonal array, was used and a total of 18 treatment combinations were run. The experimental results and the analysis are not given here. However, the optimal levels were found to be POS (new) for material, small for hole size, A mm for height, and C mm for V-notch.

*(6) Validate*

A confirmation test was attempted to validate the results of DOE and the optimality was confirmed. Finally, a cost/benefit analysis was made and the manufacturability and productivity were studied to prove all were satisfactory. Thus, the first goal of this project (magnetic shift B, yield B, and Sigma level 4.38) was achieved. From this, the cost reduction was estimated to be \$0.2/each, which is equivalent to \$0.25 million per year.



# Appendices





## Table of Acronyms

ABB	Asea Brown Boveri
ANOVA	Analysis of Variance
BB	Black Belt
BSC	Balanced Score Card
3C	Change, Customer and Competition in quality and productivity
CEO	Chief Executive Officer
CFR	Critical Functional Response
CL	Center Line
COPQ	Cost of Poor Quality
C <sub>p</sub> , C <sub>pk</sub>	Process Capability Index
CPL	Lower Capability Index
CPM	Critical Parameter Method
CPT	Color Picture Tube
CPU	Upper Capability Index
CRM	Customer Relationship Management
CST	Critical Success Theme
CSUE	Creating & Capturing, Storing & Sharing, Utilization and Evaluation
CTC	Critical-to-customer
CTQ	Critical-to-quality
DBMS	Data Base Management System
DFM	Design for Manufacturability
DFR	Design for Reliability
DFSS	Design for Six Sigma
DIDES	Define-Initiate-Design-Execute-Sustain
DMADV	Define-Measure-Analyze-Design-Verify
DMAIC	Define-Measure-Analyze-Improve-Control
DMARIC	Define-Measure-Analyze-Redesign-Implement-Control
DOE	Design of Experiments
DPMO	Defects Per Million Opportunities
DPO	Defects Per Opportunity
DPU	Defects Per Unit
DR	Design Review
DT	Data Technology
EPA	European Productivity Agency
ERP	Enterprise Resources Planning
E-CIM	Engineering Computer Integrated Manufacturing
FMEA	Failure Modes and Effects Analysis
Gauge R&R	Gauge repeatability and reproducibility
GB	Green Belt

*Six Sigma for Quality and Productivity Promotion*

GE	General Electric
IDOV	Identify-Design-Optimize-Validate
ISO	International Organization for Standardization
IT	Information Technology
JIT	Just-in-time
KBSS	Knowledge Based Six Sigma
KM	Knowledge Management
KPIV	Key Process Input Variable
KPOV	Key Process Output Variable
LCL	Lower Control Limit
LGE-DA	The Digital Appliance Company of LG Electronics
LSL	Lower Specification Limit
MAIC	Measure-Analyze-Improve-Control
MBB	Master Black Belt
MBNQA	Malcolm Baldrige National Quality Award
MRP	Material Requirement Planning
MSA	Measurement System Analysis
PDM	Product Data Management
PI	Process Innovation
ppm	Parts per million
QC	Quality Control
QFD	Quality Function Deployment
R&D	Research and Development
RPN	Risk Priority Number
RSS	Root Sum of Squares
RTY	Rolled Throughput Yield
4S	Systematic, Scientific, Statistical and Smarter
SCM	Supply Chain Management
SPC	Statistical Process Control
SQC	Statistical Quality Control
TPC	Total Productivity Control
TPM	Total Productive Maintenance
TQC	Total Quality Control
TQM	Total Quality Management
TRIZ	Teoriya Resheniya Izobretatelskih Zadach (in Russian) Theory of Inventive Problem Solving (in English)
TSS	Transactional Six Sigma
UCL	Upper Control Limit
USL	Upper Specification Limit
VOC	Voice of Customer
WB	White Belt

# Appendix A-1

## Standard Normal Distribution Table

$$P(Z \geq z) = \int_z^{\infty} \frac{1}{\sqrt{2\pi}} \exp(-t^2/2) dt$$

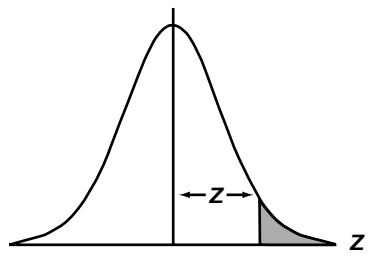

<b>Z</b>	<b>0.00</b>	<b>0.01</b>	<b>0.02</b>	<b>0.03</b>	<b>0.04</b>	<b>0.05</b>	<b>0.06</b>	<b>0.07</b>	<b>0.08</b>	<b>0.09</b>
0.0	0.5000	0.4960	0.4920	0.4880	0.4840	0.4801	0.4761	0.4721	0.4681	0.4641
0.1	0.4602	0.4562	0.4522	0.4483	0.4443	0.4404	0.4364	0.4325	0.4286	0.4247
0.2	0.4207	0.4168	0.4129	0.4090	0.4052	0.4013	0.3974	0.3936	0.3897	0.3859
0.3	0.3821	0.3783	0.3745	0.3707	0.3669	0.3632	0.3594	0.3557	0.3520	0.3483
0.4	0.3446	0.3409	0.3372	0.3336	0.3300	0.3264	0.3228	0.3192	0.3156	0.3121
0.5	0.3085	0.3050	0.3015	0.2981	0.2946	0.2912	0.2877	0.2843	0.2810	0.2776
0.6	0.2743	0.2709	0.2676	0.2643	0.2611	0.2578	0.2546	0.2514	0.2483	0.2451
0.7	0.2420	0.2389	0.2358	0.2327	0.2296	0.2266	0.2236	0.2206	0.2177	0.2148
0.8	0.2119	0.2090	0.2061	0.2033	0.2005	0.1977	0.1949	0.1922	0.1894	0.1867
0.9	0.1841	0.1814	0.1788	0.1762	0.1736	0.1711	0.1685	0.1660	0.1635	0.1611
1.0	0.1587	0.1562	0.1539	0.1515	0.1492	0.1469	0.1446	0.1423	0.1401	0.1379
1.1	0.1357	0.1335	0.1314	0.1292	0.1271	0.1251	0.1230	0.1210	0.1190	0.1170
1.2	0.1151	0.1131	0.1112	0.1093	0.1075	0.1056	0.1038	0.1020	0.1003	0.0985
1.3	0.0968	0.0951	0.0934	0.0918	0.0901	0.0885	0.0869	0.0853	0.0838	0.0823
1.4	0.0808	0.0793	0.0778	0.0764	0.0749	0.0735	0.0721	0.0708	0.0694	0.0681
1.5	0.0668	0.0655	0.0643	0.0630	0.0618	0.0606	0.0594	0.0582	0.0571	0.0559
1.6	0.0548	0.0537	0.0526	0.0516	0.0505	0.0495	0.0485	0.0475	0.0465	0.0455
1.7	0.0446	0.0436	0.0427	0.0418	0.0409	0.0401	0.0392	0.0384	0.0375	0.0367
1.8	0.0359	0.0351	0.0344	0.0336	0.0329	0.0322	0.0314	0.0307	0.0301	0.0294
1.9	0.0287	0.0281	0.0274	0.0268	0.0262	0.0256	0.0250	0.0244	0.0239	0.0233
2.0	0.0228	0.0222	0.0217	0.0212	0.0207	0.0202	0.0197	0.0192	0.0188	0.0183
2.1	0.0179	0.0174	0.0170	0.0166	0.0162	0.0158	0.0154	0.0150	0.0146	0.0143
2.2	0.0139	0.0136	0.0132	0.0129	0.0125	0.0122	0.0119	0.0116	0.0113	0.0110
2.3	0.0107	0.0104	0.0102	0.0099	0.0096	0.0094	0.0091	0.0089	0.0087	0.0084
2.4	0.0082	0.0080	0.0078	0.0075	0.0073	0.0071	0.0069	0.0068	0.0066	0.0064
2.5	0.0062	0.0060	0.0059	0.0057	0.0055	0.0054	0.0052	0.0051	0.0049	0.0048
2.6	0.0047	0.0045	0.0044	0.0043	0.0041	0.0040	0.0039	0.0038	0.0037	0.0036
2.7	0.0035	0.0034	0.0033	0.0032	0.0031	0.0030	0.0029	0.0028	0.0027	0.0026
2.8	0.0026	0.0025	0.0024	0.0023	0.0023	0.0022	0.0021	0.0021	0.0020	0.0019
2.9	0.0019	0.0018	0.0018	0.0017	0.0016	0.0016	0.0015	0.0015	0.0014	0.0014
3.0	0.0013	0.0013	0.0013	0.0012	0.0012	0.0011	0.0011	0.0011	0.0010	0.0010
3.1	0.0010	0.0009	0.0009	0.0009	0.0008	0.0008	0.0008	0.0008	0.0007	0.0007
3.2	0.0007	0.0007	0.0006	0.0006	0.0006	0.0006	0.0006	0.0005	0.0005	0.0005
3.3	0.0005	0.0005	0.0005	0.0004	0.0004	0.0004	0.0004	0.0004	0.0004	0.0003
3.4	0.0003	0.0003	0.0003	0.0003	0.0003	0.0003	0.0003	0.0003	0.0003	0.0002
3.5	0.0002	0.0002	0.0002	0.0002	0.0002	0.0002	0.0002	0.0002	0.0002	0.0002
3.6	0.0002	0.0002	0.0001	0.0001	0.0001	0.0001	0.0001	0.0001	0.0001	0.0001
3.7	0.0001	0.0001	0.0001	0.0001	0.0001	0.0001	0.0001	0.0001	0.0001	0.0001
3.8	0.0001	0.0001	0.0001	0.0001	0.0001	0.0001	0.0001	0.0001	0.0001	0.0001

## Appendix A-2

### t-distribution Table of $t(\phi; \alpha)$

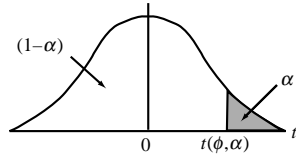

$$P[t(\phi) \leq t(\phi, \alpha)] = 1 - \alpha$$

DF. $\phi$ \ $\alpha$	0.1	0.05	0.025	0.01	0.005	0.0005
1	3.078	6.314	12.706	31.821	63.657	636.619
2	1.886	2.920	4.303	6.965	9.925	31.599
3	1.638	2.353	3.182	4.541	5.841	12.924
4	1.533	2.132	2.776	3.747	4.604	8.610
5	1.476	2.015	2.571	3.365	4.032	6.869
6	1.440	1.943	2.447	3.143	3.707	5.959
7	1.415	1.895	2.365	2.998	3.499	5.408
8	1.397	1.860	2.306	2.896	3.355	5.041
9	1.383	1.833	2.262	2.821	3.250	4.781
10	1.372	1.812	2.228	2.764	3.169	4.587
11	1.363	1.796	2.201	2.718	3.106	4.437
12	1.356	1.782	2.179	2.681	3.055	4.318
13	1.350	1.771	2.160	2.650	3.012	4.221
14	1.345	1.761	2.145	2.624	2.977	4.140
15	1.341	1.753	2.131	2.602	2.947	4.073
16	1.337	1.746	2.120	2.583	2.921	4.015
17	1.333	1.740	2.110	2.567	2.898	3.965
18	1.330	1.734	2.101	2.552	2.878	3.922
19	1.328	1.729	2.093	2.539	2.861	3.883
20	1.325	1.725	2.086	2.528	2.845	3.850
21	1.323	1.721	2.080	2.518	2.831	3.819
22	1.321	1.717	2.074	2.508	2.819	3.792
23	1.319	1.714	2.069	2.500	2.807	3.768
24	1.318	1.711	2.064	2.492	2.797	3.745
25	1.316	1.708	2.060	2.485	2.787	3.725
26	1.315	1.706	2.056	2.479	2.779	3.707
27	1.314	1.703	2.052	2.473	2.771	3.690
28	1.313	1.701	2.048	2.467	2.763	3.674
29	1.311	1.699	2.045	2.462	2.756	3.659
30	1.310	1.697	2.042	2.457	2.750	3.646
40	1.303	1.684	2.021	2.423	2.704	3.551
50	1.299	1.676	2.009	2.403	2.678	3.496
60	1.296	1.671	2.000	2.390	2.660	3.460
70	1.294	1.667	1.994	2.381	2.648	3.435
80	1.292	1.664	1.990	2.374	2.639	3.416
90	1.291	1.662	1.987	2.368	2.632	3.402
100	1.290	1.660	1.984	2.364	2.626	3.390
110	1.289	1.659	1.982	2.361	2.621	3.381
120	1.289	1.658	1.980	2.358	2.617	3.373
$\infty$	1.282	1.645	1.960	2.326	2.576	3.291

### Appendix A-3

#### F-distribution Table of $F(\phi_1, \phi_2; \alpha)$

$$P[F(\phi_1, \phi_2) \leq F(\phi_1, \phi_2; \alpha)] = 1 - \alpha$$

$$F(\phi_1, \phi_2; \alpha) = \frac{1}{F(\phi_2, \phi_1, 1 - \alpha)}$$

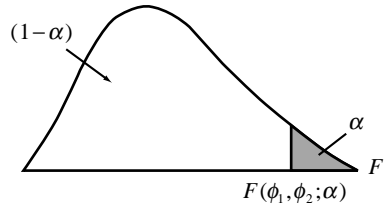

		$\phi_1$								
$\phi_2$	$\alpha$	1	2	3	4	5	6	7	8	9
1	0.1	39.86	49.50	53.59	55.83	57.24	58.20	58.91	59.44	59.86
	0.05	161.45	199.50	215.71	224.58	230.16	233.99	236.77	238.88	240.54
	0.025	647.79	799.50	864.16	899.58	921.85	937.11	948.22	956.66	963.28
	0.01	4052.18	4999.50	5403.35	5624.58	5763.65	5858.99	5928.36	5981.07	6022.47
2	0.1	8.53	9.00	9.16	9.24	9.29	9.33	9.35	9.37	9.38
	0.05	18.51	19.00	19.16	19.25	19.30	19.33	19.35	19.37	19.38
	0.025	38.51	39.00	39.17	39.25	39.30	39.33	39.36	39.37	39.39
	0.01	98.50	99.00	99.17	99.25	99.30	99.33	99.36	99.37	99.39
3	0.1	5.54	5.46	5.39	5.34	5.31	5.28	5.27	5.25	5.24
	0.05	10.13	9.55	9.28	9.12	9.01	8.94	8.89	8.85	8.81
	0.025	17.44	16.04	15.44	15.10	14.88	14.73	14.62	14.54	14.47
	0.01	34.12	30.82	29.46	28.71	28.24	27.91	27.67	27.49	27.35
4	0.1	4.54	4.32	4.19	4.11	4.05	4.01	3.98	3.95	3.94
	0.05	7.71	6.94	6.59	6.39	6.26	6.16	6.09	6.04	6.00
	0.025	12.22	10.65	9.98	9.60	9.36	9.20	9.07	8.98	8.90
	0.01	21.20	18.00	16.69	15.98	15.52	15.21	14.98	14.80	14.66
5	0.1	4.06	3.78	3.62	3.52	3.45	3.40	3.37	3.34	3.32
	0.05	6.61	5.79	5.41	5.19	5.05	4.95	4.88	4.82	4.77
	0.025	10.01	8.43	7.76	7.39	7.15	6.98	6.85	6.76	6.68
	0.01	16.26	13.27	12.06	11.39	10.97	10.67	10.46	10.29	10.16
6	0.1	3.78	3.46	3.29	3.18	3.11	3.05	3.01	2.98	2.96
	0.05	5.99	5.14	4.76	4.53	4.39	4.28	4.21	4.15	4.10
	0.025	8.81	7.26	6.60	6.23	5.99	5.82	5.70	5.60	5.52
	0.01	13.75	10.92	9.78	9.15	8.75	8.47	8.26	8.10	7.98
7	0.1	3.59	3.26	3.07	2.96	2.88	2.83	2.78	2.75	2.72
	0.05	5.59	4.74	4.35	4.12	3.97	3.87	3.79	3.73	3.68
	0.025	8.07	6.54	5.89	5.52	5.29	5.12	4.99	4.90	4.82
	0.01	12.25	9.55	8.45	7.85	7.46	7.19	6.99	6.84	6.72
8	0.1	3.46	3.11	2.92	2.81	2.73	2.67	2.62	2.59	2.56
	0.05	5.32	4.46	4.07	3.84	3.69	3.58	3.50	3.44	3.39
	0.025	7.57	6.06	5.42	5.05	4.82	4.65	4.53	4.43	4.36
	0.01	11.26	8.65	7.59	7.01	6.63	6.37	6.18	6.03	5.91
9	0.1	3.36	3.01	2.81	2.69	2.61	2.55	2.51	2.47	2.44
	0.05	5.12	4.26	3.86	3.63	3.48	3.37	3.29	3.23	3.18
	0.025	7.21	5.71	5.08	4.72	4.48	4.32	4.20	4.10	4.03
	0.01	10.56	8.02	6.99	6.42	6.06	5.80	5.61	5.47	5.35
10	0.1	3.29	2.92	2.73	2.61	2.52	2.46	2.41	2.38	2.35
	0.05	4.96	4.10	3.71	3.48	3.33	3.22	3.14	3.07	3.02
	0.025	6.94	5.46	4.83	4.47	4.24	4.07	3.95	3.85	3.78
	0.01	10.04	7.56	6.55	5.99	5.64	5.39	5.20	5.06	4.94

Appendix A-3 (continued)

$\phi_2$	$\alpha$	$\phi_1$								
		1	2	3	4	5	6	7	8	9
11	0.1	3.23	2.86	2.66	2.54	2.45	2.39	2.34	2.30	2.27
	0.05	4.84	3.98	3.59	3.36	3.20	3.09	3.01	2.95	2.90
	0.025	6.72	5.26	4.63	4.28	4.04	3.88	3.76	3.66	3.59
	0.01	9.65	7.21	6.22	5.67	5.32	5.07	4.89	4.74	4.63
12	0.1	3.18	2.81	2.61	2.48	2.39	2.33	2.28	2.24	2.21
	0.05	4.75	3.89	3.49	3.26	3.11	3.00	2.91	2.85	2.80
	0.025	6.55	5.10	4.47	4.12	3.89	3.73	3.61	3.51	3.44
	0.01	9.33	6.93	5.95	5.41	5.06	4.82	4.64	4.50	4.39
13	0.1	3.14	2.76	2.56	2.43	2.35	2.28	2.23	2.20	2.16
	0.05	4.67	3.81	3.41	3.18	3.03	2.92	2.83	2.77	2.71
	0.025	6.41	4.97	4.35	4.00	3.77	3.60	3.48	3.39	3.31
	0.01	9.07	6.70	5.74	5.21	4.86	4.62	4.44	4.30	4.19
14	0.1	3.10	2.73	2.52	2.39	2.31	2.24	2.19	2.15	2.12
	0.05	4.60	3.74	3.34	3.11	2.96	2.85	2.76	2.70	2.65
	0.025	6.30	4.86	4.24	3.89	3.66	3.50	3.38	3.29	3.21
	0.01	8.86	6.51	5.56	5.04	4.69	4.46	4.28	4.14	4.03
15	0.1	3.07	2.70	2.49	2.36	2.27	2.21	2.16	2.12	2.09
	0.05	4.54	3.68	3.29	3.06	2.90	2.79	2.71	2.64	2.59
	0.025	6.20	4.77	4.15	3.80	3.58	3.41	3.29	3.20	3.12
	0.01	8.68	6.36	5.42	4.89	4.56	4.32	4.14	4.00	3.89
16	0.1	3.05	2.67	2.46	2.33	2.24	2.18	2.13	2.09	2.06
	0.05	4.49	3.63	3.24	3.01	2.85	2.74	2.66	2.59	2.54
	0.025	6.12	4.69	4.08	3.73	3.50	3.34	3.22	3.12	3.05
	0.01	8.53	6.23	5.29	4.77	4.44	4.20	4.03	3.89	3.78
17	0.1	3.03	2.64	2.44	2.31	2.22	2.15	2.10	2.06	2.03
	0.05	4.45	3.59	3.20	2.96	2.81	2.70	2.61	2.55	2.49
	0.025	6.04	4.62	4.01	3.66	3.44	3.28	3.16	3.06	2.98
	0.01	8.40	6.11	5.18	4.67	4.34	4.10	3.93	3.79	3.68
18	0.1	3.01	2.62	2.42	2.29	2.20	2.13	2.08	2.04	2.00
	0.05	4.41	3.55	3.16	2.93	2.77	2.66	2.58	2.51	2.46
	0.025	5.98	4.56	3.95	3.61	3.38	3.22	3.10	3.01	2.93
	0.01	8.29	6.01	5.09	4.58	4.25	4.01	3.84	3.71	3.60
19	0.1	2.99	2.61	2.40	2.27	2.18	2.11	2.06	2.02	1.98
	0.05	4.38	3.52	3.13	2.90	2.74	2.63	2.54	2.48	2.42
	0.025	5.92	4.51	3.90	3.56	3.33	3.17	3.05	2.96	2.88
	0.01	8.18	5.93	5.01	4.50	4.17	3.94	3.77	3.63	3.52
20	0.1	2.97	2.59	2.38	2.25	2.16	2.09	2.04	2.00	1.96
	0.05	4.35	3.49	3.10	2.87	2.71	2.60	2.51	2.45	2.39
	0.025	5.87	4.46	3.86	3.51	3.29	3.13	3.01	2.91	2.84
	0.01	8.10	5.85	4.94	4.43	4.10	3.87	3.70	3.56	3.46
24	0.1	2.93	2.54	2.33	2.19	2.10	2.04	1.98	1.94	1.91
	0.05	4.26	3.40	3.01	2.78	2.62	2.51	2.42	2.36	2.30
	0.025	5.72	4.32	3.72	3.38	3.15	2.99	2.87	2.78	2.70
	0.01	7.82	5.61	4.72	4.22	3.90	3.67	3.50	3.36	3.26
30	0.1	2.88	2.49	2.28	2.14	2.05	1.98	1.93	1.88	1.85
	0.05	4.17	3.32	2.92	2.69	2.53	2.42	2.33	2.27	2.21
	0.025	5.57	4.18	3.59	3.25	3.03	2.87	2.75	2.65	2.57
	0.01	7.56	5.39	4.51	4.02	3.70	3.47	3.30	3.17	3.07
60	0.1	2.79	2.39	2.18	2.04	1.95	1.87	1.82	1.77	1.74
	0.05	4.00	3.15	2.76	2.53	2.37	2.25	2.17	2.10	2.04
	0.025	5.29	3.93	3.34	3.01	2.79	2.63	2.51	2.41	2.33
	0.01	7.08	4.98	4.13	3.65	3.34	3.12	2.95	2.82	2.72
120	0.1	2.75	2.35	2.13	1.99	1.90	1.82	1.77	1.72	1.68
	0.05	3.92	3.07	2.68	2.45	2.29	2.18	2.09	2.02	1.96
	0.025	5.15	3.80	3.23	2.89	2.67	2.52	2.39	2.30	2.22
	0.01	6.85	4.79	3.95	3.48	3.17	2.96	2.79	2.66	2.56
$\infty$	0.1	2.71	2.30	2.08	1.95	1.85	1.77	1.72	1.67	1.63
	0.05	3.84	3.00	2.61	2.37	2.21	2.10	2.01	1.94	1.88
	0.025	5.03	3.69	3.12	2.79	2.57	2.41	2.29	2.19	2.11

Appendix A-3 (continued)

$\phi_2$	$\alpha$	$\phi_1$									
		10	11	12	15	20	24	30	60	120	$\infty$
1	0.100	60.19	60.47	60.71	61.22	61.74	62.00	62.26	62.79	63.06	63.32
	0.050	241.88	242.98	243.91	245.95	248.01	249.05	250.10	252.20	253.25	254.30
	0.025	968.63	973.03	976.71	984.87	993.10	997.25	1001.41	1009.80	1014.02	1018.21
	0.010	6055.85	6083.32	6106.32	6157.28	6208.73	6234.63	6260.65	6313.03	6339.39	6365.55
2	0.100	9.39	9.40	9.41	9.42	9.44	9.45	9.46	9.47	9.48	9.49
	0.050	19.40	19.40	19.41	19.43	19.45	19.45	19.46	19.48	19.49	19.50
	0.025	39.40	39.41	39.41	39.43	39.45	39.46	39.46	39.48	39.49	39.50
	0.010	99.40	99.41	99.42	99.43	99.45	99.46	99.47	99.48	99.49	99.50
3	0.100	5.23	5.22	5.22	5.20	5.18	5.18	5.17	5.15	5.14	5.13
	0.050	8.79	8.76	8.74	8.70	8.66	8.64	8.62	8.57	8.55	8.53
	0.025	14.42	14.37	14.34	14.25	14.17	14.12	14.08	13.99	13.95	13.90
	0.010	27.23	27.13	27.05	26.87	26.69	26.60	26.50	26.32	26.22	26.13
4	0.100	3.92	3.91	3.90	3.87	3.84	3.83	3.82	3.79	3.78	3.76
	0.050	5.96	5.94	5.91	5.86	5.80	5.77	5.75	5.69	5.66	5.63
	0.025	8.84	8.79	8.75	8.66	8.56	8.51	8.46	8.36	8.31	8.26
	0.010	14.55	14.45	14.37	14.20	14.02	13.93	13.84	13.65	13.56	13.46
5	0.100	3.30	3.28	3.27	3.24	3.21	3.19	3.17	3.14	3.12	3.11
	0.050	4.74	4.70	4.68	4.62	4.56	4.53	4.50	4.43	4.40	4.37
	0.025	6.62	6.57	6.52	6.43	6.33	6.28	6.23	6.12	6.07	6.02
	0.010	10.05	9.96	9.89	9.72	9.55	9.47	9.38	9.20	9.11	9.02
6	0.100	2.94	2.92	2.90	2.87	2.84	2.82	2.80	2.76	2.74	2.72
	0.050	4.06	4.03	4.00	3.94	3.87	3.84	3.81	3.74	3.70	3.67
	0.025	5.46	5.41	5.37	5.27	5.17	5.12	5.07	4.96	4.90	4.85
	0.010	7.87	7.79	7.72	7.56	7.40	7.31	7.23	7.06	6.97	6.88
7	0.100	2.70	2.68	2.67	2.63	2.59	2.58	2.56	2.51	2.49	2.47
	0.050	3.64	3.60	3.57	3.51	3.44	3.41	3.38	3.30	3.27	3.23
	0.025	4.76	4.71	4.67	4.57	4.47	4.41	4.36	4.25	4.20	4.14
	0.010	6.62	6.54	6.47	6.31	6.16	6.07	5.99	5.82	5.74	5.65
8	0.100	2.54	2.52	2.50	2.46	2.42	2.40	2.38	2.34	2.32	2.29
	0.050	3.35	3.31	3.28	3.22	3.15	3.12	3.08	3.01	2.97	2.93
	0.025	4.30	4.24	4.20	4.10	4.00	3.95	3.89	3.78	3.73	3.67
	0.010	5.81	5.73	5.67	5.52	5.36	5.28	5.20	5.03	4.95	4.86
9	0.100	2.42	2.40	2.38	2.34	2.30	2.28	2.25	2.21	2.18	2.16
	0.050	3.14	3.10	3.07	3.01	2.94	2.90	2.86	2.79	2.75	2.71
	0.025	3.96	3.91	3.87	3.77	3.67	3.61	3.56	3.45	3.39	3.33
	0.010	5.26	5.18	5.11	4.96	4.81	4.73	4.65	4.48	4.40	4.31
10	0.100	2.32	2.30	2.28	2.24	2.20	2.18	2.16	2.11	2.08	2.06
	0.050	2.98	2.94	2.91	2.85	2.77	2.74	2.70	2.62	2.58	2.54
	0.025	3.72	3.66	3.62	3.52	3.42	3.37	3.31	3.20	3.14	3.08
	0.010	4.85	4.77	4.71	4.56	4.41	4.33	4.25	4.08	4.00	3.91
11	0.100	2.25	2.23	2.21	2.17	2.12	2.10	2.08	2.03	2.00	1.97
	0.050	2.85	2.82	2.79	2.72	2.65	2.61	2.57	2.49	2.45	2.41
	0.025	3.53	3.47	3.43	3.33	3.23	3.17	3.12	3.00	2.94	2.88
	0.010	4.54	4.46	4.40	4.25	4.10	4.02	3.94	3.78	3.69	3.60
12	0.100	2.19	2.17	2.15	2.10	2.06	2.04	2.01	1.96	1.93	1.90
	0.050	2.75	2.72	2.69	2.62	2.54	2.51	2.47	2.38	2.34	2.30
	0.025	3.37	3.32	3.28	3.18	3.07	3.02	2.96	2.85	2.79	2.73
	0.010	4.30	4.22	4.16	4.01	3.86	3.78	3.70	3.54	3.45	3.36
13	0.100	2.14	2.12	2.10	2.05	2.01	1.98	1.96	1.90	1.88	1.85
	0.050	2.67	2.63	2.60	2.53	2.46	2.42	2.38	2.30	2.25	2.21
	0.025	3.25	3.20	3.15	3.05	2.95	2.89	2.84	2.72	2.66	2.60
	0.010	4.10	4.02	3.96	3.82	3.66	3.59	3.51	3.34	3.25	3.17
14	0.100	2.10	2.07	2.05	2.01	1.96	1.94	1.91	1.86	1.83	1.80
	0.050	2.60	2.57	2.53	2.46	2.39	2.35	2.31	2.22	2.18	2.13
	0.025	3.15	3.09	3.05	2.95	2.84	2.79	2.73	2.61	2.55	2.49
	0.010	3.94	3.86	3.80	3.66	3.51	3.43	3.35	3.18	3.09	3.01

Appendix A-3 (continued)

$\phi_2$	$\alpha$	$\phi_1$									
		10	11	12	15	20	24	30	60	120	$\infty$
15	0.100	2.06	2.04	2.02	1.97	1.92	1.90	1.87	1.82	1.79	1.76
	0.050	2.54	2.51	2.48	2.40	2.33	2.29	2.25	2.16	2.11	2.07
	0.025	3.06	3.01	2.96	2.86	2.76	2.70	2.64	2.52	2.46	2.40
	0.010	3.80	3.73	3.67	3.52	3.37	3.29	3.21	3.05	2.96	2.87
16	0.100	2.03	2.01	1.99	1.94	1.89	1.87	1.84	1.78	1.75	1.72
	0.050	2.49	2.46	2.42	2.35	2.28	2.24	2.19	2.11	2.06	2.01
	0.025	2.99	2.93	2.89	2.79	2.68	2.63	2.57	2.45	2.38	2.32
	0.010	3.69	3.62	3.55	3.41	3.26	3.18	3.10	2.93	2.84	2.75
17	0.100	2.00	1.98	1.96	1.91	1.86	1.84	1.81	1.75	1.72	1.69
	0.050	2.45	2.41	2.38	2.31	2.23	2.19	2.15	2.06	2.01	1.96
	0.025	2.92	2.87	2.82	2.72	2.62	2.56	2.50	2.38	2.32	2.25
	0.010	3.59	3.52	3.46	3.31	3.16	3.08	3.00	2.83	2.75	2.65
18	0.100	1.98	1.95	1.93	1.89	1.84	1.81	1.78	1.72	1.69	1.66
	0.050	2.41	2.37	2.34	2.27	2.19	2.15	2.11	2.02	1.97	1.92
	0.025	2.87	2.81	2.77	2.67	2.56	2.50	2.44	2.32	2.26	2.19
	0.010	3.51	3.43	3.37	3.23	3.08	3.00	2.92	2.75	2.66	2.57
19	0.100	1.96	1.93	1.91	1.86	1.81	1.79	1.76	1.70	1.67	1.63
	0.050	2.38	2.34	2.31	2.23	2.16	2.11	2.07	1.98	1.93	1.88
	0.025	2.82	2.76	2.72	2.62	2.51	2.45	2.39	2.27	2.20	2.13
	0.010	3.43	3.36	3.30	3.15	3.00	2.92	2.84	2.67	2.58	2.49
20	0.100	1.94	1.91	1.89	1.84	1.79	1.77	1.74	1.68	1.64	1.61
	0.050	2.35	2.31	2.28	2.20	2.12	2.08	2.04	1.95	1.90	1.84
	0.025	2.77	2.72	2.68	2.57	2.46	2.41	2.35	2.22	2.16	2.09
	0.010	3.37	3.29	3.23	3.09	2.94	2.86	2.78	2.61	2.52	2.42
24	0.100	1.88	1.85	1.83	1.78	1.73	1.70	1.67	1.61	1.57	1.53
	0.050	2.25	2.22	2.18	2.11	2.03	1.98	1.94	1.84	1.79	1.73
	0.025	2.64	2.59	2.54	2.44	2.33	2.27	2.21	2.08	2.01	1.94
	0.010	3.17	3.09	3.03	2.89	2.74	2.66	2.58	2.40	2.31	2.21
30	0.100	1.82	1.79	1.77	1.72	1.67	1.64	1.61	1.54	1.50	1.46
	0.050	2.16	2.13	2.09	2.01	1.93	1.89	1.84	1.74	1.68	1.62
	0.025	2.51	2.46	2.41	2.31	2.20	2.14	2.07	1.94	1.87	1.79
	0.010	2.98	2.91	2.84	2.70	2.55	2.47	2.39	2.21	2.11	2.01
60	0.100	1.71	1.68	1.66	1.60	1.54	1.51	1.48	1.40	1.35	1.29
	0.050	1.99	1.95	1.92	1.84	1.75	1.70	1.65	1.53	1.47	1.39
	0.025	2.27	2.22	2.17	2.06	1.94	1.88	1.82	1.67	1.58	1.48
	0.010	2.63	2.56	2.50	2.35	2.20	2.12	2.03	1.84	1.73	1.60
120	0.100	1.65	1.63	1.60	1.55	1.48	1.45	1.41	1.32	1.26	1.19
	0.050	1.91	1.87	1.83	1.75	1.66	1.61	1.55	1.43	1.35	1.26
	0.025	2.16	2.10	2.05	1.94	1.82	1.76	1.69	1.53	1.43	1.31
	0.010	2.47	2.40	2.34	2.19	2.03	1.95	1.86	1.66	1.53	1.38
$\infty$	0.100	1.60	1.57	1.55	1.49	1.42	1.38	1.34	1.24	1.17	1.00
	0.050	1.83	1.79	1.75	1.67	1.57	1.52	1.46	1.32	1.22	1.00
	0.025	2.05	1.99	1.95	1.83	1.71	1.64	1.57	1.39	1.27	1.00
	0.010	2.32	2.25	2.19	2.04	1.88	1.79	1.70	1.48	1.33	1.00

## Appendix A-4

### Control Limits for Various Control Charts

Sample Size n	$\bar{x}$		$\sigma$					$R$			
	A	A <sub>2</sub>	C <sub>2</sub>	B <sub>1</sub>	B <sub>2</sub>	B <sub>3</sub>	B <sub>4</sub>	d <sub>2</sub>	d <sub>3</sub>	D <sub>3</sub>	D <sub>4</sub>
2	2.121	1.880	0.5642	0.000	1.843	0.000	3.267	1.128	0.853	0.000	3.267
3	1.732	1.023	0.7236	0.000	1.858	0.000	2.568	1.693	0.888	0.000	2.575
4	1.501	0.729	0.7979	0.000	1.808	0.000	2.266	2.059	0.880	0.000	2.282
5	1.342	0.577	0.8407	0.000	1.756	0.000	2.089	2.326	0.864	0.000	2.115
6	1.225	0.483	0.8686	0.026	1.711	0.030	1.970	2.534	0.848	0.000	2.004
7	1.134	0.419	0.8882	0.105	1.672	0.118	1.882	2.704	0.833	0.076	1.924
8	1.061	0.373	0.9027	0.167	1.638	0.185	1.815	2.847	0.820	0.736	1.864
9	1.000	0.337	0.9139	0.219	1.609	0.239	1.761	2.970	0.808	0.184	1.816
10	0.949	0.308	0.9227	0.262	1.584	0.284	1.716	3.078	0.797	0.223	1.777
11	0.905	0.285	0.9300	0.299	1.561	0.321	1.679	3.173	0.787	0.256	1.744
12	0.866	0.266	0.9359	0.331	1.541	0.354	1.646	3.258	0.778	0.284	1.719
13	0.832	0.249	0.9410	0.359	1.523	0.382	1.618	3.336	0.770	0.308	1.692
14	0.802	0.235	0.9453	0.384	1.507	0.406	1.594	3.407	0.762	0.329	1.671
15	0.775	0.223	0.9490	0.406	1.492	0.428	1.572	3.472	0.755	0.348	1.652
16	0.750	0.212	0.9523	0.427	1.478	0.448	1.552	3.532	0.749	0.364	1.636
17	0.728	0.203	0.9551	0.445	1.465	0.466	1.534	3.588	0.743	0.379	1.621
18	0.707	0.194	0.9576	0.461	1.454	0.482	1.518	3.640	0.738	0.392	1.608
19	0.688	0.187	0.9599	0.477	1.443	0.497	1.503	3.689	0.733	0.404	1.596
20	0.671	0.180	0.9619	0.491	1.433	0.510	1.490	3.735	0.729	0.414	1.586

## Appendix A-5

### GE Quality 2000: A Dream with a Great Plan

John F. Welch, Jr., was chairman and CEO of GE Corporation. His speech was presented at the GE 1996 Annual Meeting in Charlottesville, Virginia, on April 24, 1996, and published in the August/September issue of *Executive Speeches*, 1996. This speech is regarded as a milestone of Six Sigma history in the world. The part of his speech which is related to quality and Six Sigma is given here.

---

*The business performance of 222,000 employees worldwide has made us very proud as well. 1995 was another outstanding year for the company by any measure: a 17% growth in revenues to \$70 billion, 11% earnings growth to \$6.6 billion, and earnings per share up 13%. Our shareowners had a 45% return on their investment in 1995. GE, whose market capitalization already was the highest in the U.S., achieved that status globally in 1995, and is now the world's most valuable company.*

*Self-confidence and stretch thinking were two of the key factors that encouraged us to launch, in 1995, the most challenging stretch goal of all the biggest opportunity for growth, increased profitability and individual employee satisfaction in the history of our company. We have set for ourselves the goal of becoming, by the year 2000, a Six Sigma quality company, which means a company that produces virtually defect-free products, services and transactions. Six sigma is a level of quality that to date has been approached by only a handful of companies, among them several in Japan, with Motorola being the acknowledged leader in this country.*

*GE today is a quality company. It has always been a quality company. Quality improvement at GE has never taken a back seat. We have operated under the theory that if we improved our speed, our productivity, our employee and supplier involvement, and pursued other business and cultural*

*initiatives, quality would be a natural by product. And it has been. It's gotten better with each succeeding generation of product and service. But it has not improved enough to get us to the quality levels of that small circle of excellent global companies that had survived the intense competitive assault by themselves, achieving new levels of quality.*

*This Six Sigma journey will change the paradigm from fixing products so that they are perfect to fixing processes so that they produce nothing but perfection, or close to it. Typical processes at GE generate about 35,000 defects per million, which sounds like a lot, and is a lot, but it is consistent with the defect levels of most successful companies. The number of defects per million is referred to in the very precise jargon of statistics as about three and one-half sigma. For those of you who flew to Charlottesville, you are sitting here in your seats today because the airlines' record in getting passengers safely from one place to another is even better than six sigma, with less than one-half failure per million. However, if your bags did not arrive with you, it's because airline baggage operations are in the 35,000 to 50,000 defect range, which is typical of manufacturing and service operations, as well as other human activities such as writing up restaurant bills, payroll processing, and prescription writing by doctors.*

*The experience of others indicates that the cost of this three to four sigma quality is typically 10%–15% of revenues. In GE's case, with over \$70 billion in revenues, that amounts to some \$7–10 billion annually, mostly in scrap, reworking of parts and rectifying mistakes in transactions. So the financial rationale for embarking on this quality journey is clear. But beyond the pure financials, there are even more important rewards that will come with dramatically improved quality. Among them: the unlimited growth from selling products and services universally recognized by customers as being on a completely different plane of quality than those of our competitors; and the resulting pride, job satisfaction and job security from this volume growth for GE employees.*

*Six Sigma will be an exciting journey and the most difficult and invigorating stretch goal we have ever undertaken.*

*The magnitude of the challenge of going from 35,000 defects per million to fewer than four defects is huge. It will require us to reduce defects rates 10,000 fold – about 84% per year for five consecutive years – an enormous task, one that stretches even the concept of stretch behavior.*

*Motorola has defined a rigorous and proven process for improving each of the tens of millions of processes that produce the goods and services a company provides. The methodology is called the Six Sigma process and involves four simple but rigorous steps: first, measuring every process and transaction, then analyzing each of them, then painstakingly improving them, and finally rigorously controlling them for consistency once they have been improved.*

*Following Motorola's experience closely, we have selected, trained and put in place the key people to lead this Six Sigma effort. We've selected our "Champions" – senior managers who define the projects. We've trained 200 "Master Black Belts" – full-time teachers with heavy quantitative skills as well as teaching and leadership ability. We've selected and trained 800 "Black Belts" – full-time quality executives who lead teams and focus on key processes, reporting the results back to the Champions. We are beginning to train each of our 20,000 engineers so that all of our new products and services will be designed for Six Sigma production. And we have, at our Leadership Development Institute at Crotonville and at our businesses, an unmatched educational capability to train all 222,000 GE people in Six Sigma methodology.*

*We have a work-out culture in place at GE that is ideal for highly collaborative action-based team efforts, which will enhance our Six Sigma programs. To emphasize the importance of this initiative, we have weighted 40% of the bonus compensation for our managers on the intensity of their efforts and their progress toward Six Sigma quality in their operations. To date, we have committed \$200 million to this effort, and we have the balance sheet that will permit us to spend whatever is required to get to our goal. The return on this investment will be enormous. Very little of this requires invention. We have taken a proven methodology, adapted it*

*to a boundaryless culture, and are providing our teams every resource they will need to win.*

*Six Sigma – GE Quality 2000 – will be the biggest, the most personally rewarding and, in the end, the most profitable undertaking in our history. GE today is the world's most valuable company. The numbers tell us that. We are the most exciting global company to work for. Our associates tell us that. By 2000, we want to be an even better company, a company not just better in quality than its competitors – we are that today – but a company 10,000 times better than its competitors. That recognition will come not from us but from our customers.*

*Six Sigma – GE Quality 2000 – is a dream, but a dream with a plan behind it. It is a dream that is increasingly inspiring and exciting everyone in this company. We have the resources, the will, and above all, the greatest people in world business who will make it come true.*

## References

---

- Bhote, K.R. (1989). Motorola's long march to the Malcolm Baldrige National Quality Award, *National Productivity Review*, 8 (4), pp.365-376.
- Box, G.E.B., Hunter, W.G. and Hunter, J.S. (1978) *Statistics for Experimenters*, New York, John Wiley & Sons.
- Breyfogle, F.W. (1999). *Implementing Six Sigma: Smarter Solutions Using Statistical Methods* (2nd ed), New York, John Wiley & Sons.
- Brown, L.A., Lowe, V. W. and Benham, D.R. (1991). *Fundamental Statistical Process Control Reference Manual*, Provided jointly by GM, Ford and Chrysler in Collaboration with ASQ.
- Deming, W.E. (1986). *Out of the Crisis*, MIT Center for Advanced Engineering Study, Cambridge, MA. pp.23-24, 97-98.
- Denecke, J. (1998). 6 Sigma and Lean Synergy, Allied Signal Black Belt Symposium, AlliedSignal Inc., pp.1-16.
- Feigenbaum (1961). *Total Quality Control; Engineering and Management*, McGraw-Hill Company, New York.
- General Electric (1997). *General Electric Company 1997 Annual Report*.
- Godfrey, A.B. (1999). Building a scorecard, *Quality Digest*, 19(12), p.16.
- Harry, M.J. (1998). *The Vision of Six Sigma*, 8 volumes, Phoenix, Arizona, Tri Star Publishing.
- Hendricks, C.A. and Kelbaugh, R.L. (1998). Implementing Six Sigma at GE, Association for Quality & Participation, 21(4), pp. 48-53.
- Juran, J.M. (1988). *Juran on Planning for Quality*, Free Press, New York.
- Jusko, J. (1999). A Look at Lean, *Industrial Week*, December 6.
- Kaplan, R.S. and Norton, D.P. (1992). The balanced scorecard – measures that drive performance, *Harvard Business Review*, 70(1), pp.71-79.
- Kaplan, R.S. and Norton, D.P. (1993). Putting the balanced scorecard to work, *Harvard Business Review*, 71(5), pp.138-140.
- Kaplan, R.S. and Norton, D.P. (1996). *The Balanced Scorecard*, Harvard Business School Press, Boston, MA.

- 
- LG Electronics (2000). *Six Sigma Case Studies for Quality Improvement*, prepared for the National Quality Prize of Six Sigma for 2000 by LG Electronics / Digital Appliance Company.
- LG Electronics (2002). Six Sigma enables LG Electronics to improve business performance, an explanatory paper provided by LG Electronics/Digital Appliance Company.
- Logothetis, N. and Wynn, H.P. (1989). *Quality through Design: Experimental Design, Offline Quality Control and Taguchi's Contributions*, Oxford, Clarendon Press.
- Losianowycz, G. (1999). Six Sigma Quality: A Driver to Cultural Change & Improvement, an invited lecture by Korean Standards Association at Seoul. (Ms. Losianowycz is a senior lecturer at Motorola University.)
- Magnusson, K., Kroslid, D. and Bergman, B. (2000). *Six Sigma: The Pragmatic Approach*, Studentlitteratur, Sweden.
- Pande, P.S., Neuman, R.P. and Cavanagh, R.R. (2000). *The Six Sigma Way*, McGraw-Hill, New York.
- Park, S. H. (1996). *Robust Design and Analysis for Quality Engineering*, Suffolk, Chapman & Hall.
- Park, S.H. and Vining, G.G. (2000). *Statistical Process Monitoring and Optimization*, Marcel Dekker, New York.
- Park, S. H. (1984). *Statistical Quality Control*, Minyoung-sa, Seoul. (in Korean)
- Park, S.H., Park, Y.H. and Lee, M.J. (1997). *Statistical Process Control*, Minyoung-sa, Seoul. (in Korean)
- Park, S.H. and Kim, K.H. (2000). A study of Six Sigma for R&D part, *Quality Revolution*, 1(1), Korean Society for Quality Management, pp.51-65.
- Park, S.H., Lee, M.J. and Chung, M.Y. (1999). *Theory and Practice of Six Sigma*, Publishing Division of Korean Standards Association, Seoul.
- Park, S.H., Lee, M.J. and Lee, K.K. (2001). *DFSS: Design for Six Sigma*, Publishing Division of Korean Standards Association, Seoul.

Pyzdek, T. (1999). *The Complete Guide to Six Sigma*, p. 431, Quality Publishing, Tucson, AZ.

Pyzdek T. (2000). *Six Sigma and Lean Production*, Quality Digest, p. 14.

Samsung SDI. (2000a). *Explanation Book of the Current Status of Six Sigma*, Prepared for the National Quality Prize of Six Sigma for 2000 by Samsung SDI.

Samsung SDI. (2000b). *Six Sigma Case Studies for Quality Innovation*, Samsung SDI reports.

Sase, T. (2001). *Practical Productivity Analysis for Innovative Action*, Asian Productivity Organization, Tokyo.

Slator, R. (2001). *The GE Way Fieldbook: Jack Welch's Battle Plan for Corporate Revolution*, McGraw-Hill, New York, NY.

Snee, R. (1999). Why Should Statisticians Pay Attention to Six Sigma?: An Examination for Their Role in the Six Sigma Methodology, *Quality Progress*, 32(9), pp. 100-103.

Taguchi, G. (1986). *Introduction to Quality Engineering*, Asian Productivity Organization, Tokyo.

Taguchi, G. (1987). *System of Experimental Design*, Unipublication Kraus International, White Plains, New York.

Tomkins, R. (1997). GE beats expected 13% rise, *Financial Times*, (10 October), p.22.

# Index

---

- ABB (Asea Brown Boveri), 56
- Akao, Y., 88
- ANOVA (analysis of variance), 109, 170, 187
  - pooled ANOVA table, 111
  - interaction, 111
- Assignable causes, 8
  
- Barnevik, P., 56
- BB (black belts), 34
- BB courses, 35, 57, 156
  - job description, 159
- Belt system, 3, 66
- Bergman, B., 1, 165
- Bhote, K.R., 1
- Binomial distribution, 19
- Box, G.E.P., 105
- BSC (balanced scorecard), 118
  
- Cause-and-effect diagram, 166, 169
- CEO (chief executive officer), 31
- CFR (critical functional response), 179
- Check sheet, 75
- Common causes, 8
- Champion, 34
- Continuous characteristics, 6
- Control chart, 76
  - construction of control charts, 78
  - CL (center line), 77
  - LCL (lower control limit), 77
  - UCL (upper control limit), 77
- Control factor, 6
- Conway, W.E., 123
- Correlation analysis, 99
  - sample correlation coefficient, 102
- COPQ (cost of poor quality), 123, 149, 152
  - hidden quality cost, 124
- CPM (critical parameter method), 180
- CRM (customer relationship management), 146
- CST (critical success theme), 172
- CSUE cycle, 144
- CTC (critical-to-customer), 34
- CTQ (critical-to-quality), 2, 10
- CTQx, 2
- CTQy, 2
- Customer satisfaction, 10
- Cycle time, 7, 9
  
- DBMS (data base management system), 42
- Defect rate, 14
- Deming, W.E., 29
- Denecke, J., 132
- DFSS (Design for Six Sigma), 31
- DFSS process, 45
- DIDES, 43
- Discrete characteristics, 6
- DMADV, 43
- DMAIC, 30
- DMAIC process, 37
  - flowchart of DMAIC process, 40
- DMARIC, 43, 50
- DOE (design of experiments), 39, 158, 182
  - framework of DOE, 104
  - classification of DOE, 106
- DPMO (defects per million opportunities), 14, 18, 57
- DPO (defects per opportunity), 18
- DPU (defects per unit), 16
- DR (design review), 65
- DT (data technology), 138
  
- e-business, 139, 146
  - CQCD, 150

- ECIM (engineering computer integrated manufacturing), 65  
e-Sigma, 146
- Factorial design, 59, 105, 158  
Feigenbaum, A.V., 122  
Fisher, G., 54  
Fisher, R.A., 105  
FMEA (failure modes and effects analysis), 112  
    design FMEA, 112  
    process FMEA, 118  
5M1E, 74  
4S, 3  
Fractional factorial design, 104
- Galvin, R., 1, 32, 51  
Galvin, P., 51  
GB (green belts), 34  
GE (General Electric), 2, 4, 32, 54, 55, 120  
    Medical Systems, 55  
GE Capital Services, 155  
Godfrey, A.B., 120
- Harry, M., 1, 52, 56  
Hendricks, C.A., 2  
Histogram, 80  
House of quality, 90  
Hypothesis testing, 96  
    null hypothesis, 96  
    alternative hypothesis, 96  
    type I error, 97  
    type II error, 97
- IDOV, 43, 65, 178  
IDOV steps, 46  
Incomplete block design, 107  
Input variables, 5
- Ishikawa, K., 74  
ISO 9000 series, 129  
ISO 9000:2000, 130  
IT (information technology), 138
- JIT (just-in-time), 132  
Juran, J.M., 51, 81, 124  
Jusko, J., 132
- Kaplan, R.S., 118, 120  
KBSS (knowledge based Six Sigma), 143  
Kelbaugh, R.L., 2  
Kim, K., 48  
KM (knowledge management), 41, 143  
knowledge triangle, 141  
    CSUE cycle, 144  
KPIV (key process input variable), 88  
KPOV (key process output variable), 88  
Kroslid, D., iv, 165
- Lean manufacturing, 131  
LG Electronics, 45, 60, 67  
Lindahl, G., 56  
Location, 7  
Losianowycz, G., 1
- Magnusson, K., 11  
MAP (management action plans), 172  
Matrix mapping, 64  
MBB (master black belts), 34  
MBNQA (Malcolm Baldrige National Quality Award), 134  
Measurement system, 36  
Mizuno, S., 88  
Mixture design, 107  
Motorola, 1, 4, 51  
MRP (material requirement planning), 42

- 
- National quality awards, 134
    - EQA (European Quality Award), 134
    - Deming Prize, 134
    - Korean National Quality Grand Prize, 134
    - MBNQA, 134
    - Six Sigma, 60, 134
  - Noise factor, 6
  - Normal distribution, 12
  - Nortan, D.P., 120
  
  - Pareto chart, 81
  - Pareto, V., 81
    - construction of Pareto chart, 82
  - Park, S.H., 2, 48, 144
  - PI (process innovation), 61
  - Poisson distribution, 18
  - Potential process capability index (Cp), 20
  - ppm (parts per million), 14
    - 100 PPM, 68
  - Process:
    - process, 5
    - process capability, 20
    - process capability index (Cpk), 20, 21
    - process flowchart, 85
    - process mapping, 88
    - process performance, 5, 11
    - process performance triangle, 7, 11
  - Productivity:
    - definition, 9
    - relationship between quality and productivity, 27
  - Project selection, 64
    - selection of project themes, 45
  - Project team activities, 41, 44, 48, 146
    - flow, 49
  - Pyzdek, T., 56, 132
  
  - QC (quality control), 3
    - circles, 74
    - 7QC tools, 74
  - QFD (quality function deployment), 10, 88
    - four phases of QFD, 89
    - house of quality of QFD, 90
    - relationship matrix of QFD, 91
  - Quality:
    - circle, 43
    - level, 14
    - relationship between quality and productivity, 27
  - Quality costs:
    - definition, 122
    - appraisal cost, 123
    - failure cost, 123
    - prevention cost, 123
  
  - Randomized complete block design, 106
  - R-D-I-D-O-V process, 178
  - Regression analysis, 102
    - simple linear regression model, 102
  - Relationship matrix, 92
  - Response surface design, 107
  - Result variable, 6
  - Robust, 6
  - Robust design, 107
  - RPN (risk priority number), 116
  - RTY (rolled throughput yield), 24
  
  - Samsung SDI, 2, 60
  - Sase, T., 9
  - SBTI (Six Sigma Breakthrough Inc.), 61
  - Scatter diagram, 83
  - Schroeder, R., 52
  - SCM (supply chain management), 146
  - Self-Assessment, 129

- Seven quality control tools (7QC tools), 74
- Shape, 7
- Shewhart, W.A., 76
- Sigma(s), 1
- Sigma (quality) level, 14
  - quality level, 14
  - unified quality level, 25
- Six Sigma:
  - day, 42
  - definition, 1, 2, 3
  - essence, 3
  - focus, 72
  - framework, 30
  - infrastructure, 70
  - roadmap, 69
  - seven step roadmap, 147
  - seven steps of introduction, 136
  - six steps of Motorola, 53
  - ten secrets of success, 58
- Slator, R., 120
- Smith, B., 52
- Snee, R., 126
- SPC (statistical process control), 39
- Special causes, 8
- Spread, 7
- SQC (statistical quality control), 3
- Stakeholder involvement, 33
- Standard deviation, 12
- Standard normal variable, 13
- Stratification, 85
  
- 3C, 4
- Tomkins, R., 1
- Top-level management commitment, 31
- TPC (total productivity control), 68
- TQC (total quality control), 3, 68
- TQM (total quality management), 3, 126
- TSS (Transactional Six Sigma), 31, 48
  
- Variation, 6, 7
- VOC (voice of customers), 34, 146, 152
  
- WB (white belts), 34
- Welch, J.F., 32, 55, 120, 196
- Wook, S., 62
  
- Yield, 7, 9
- Yurko, A., 32

## THE AUTHOR

Professor Sung H. Park, a prominent scholar in Asia, has been actively involved in the promotion and enhancement of quality and productivity in Korea since 1977. He has published more than 30 books on statistics and quality control including two books in English; one titled “Robust Design and Analysis for Quality Engineering” (Chapman & Hall), and the other called “Statistical Process Monitoring and Optimization” (Marcel Dekker). Dr. Park graduated from Seoul National University, Korea, in 1968 with a Bachelor of Science in Chemical Engineering. In 1970 he went to the USA to study Operations Research for his Master of Science Degree, and Statistics for his Ph.D. degree at North Carolina State University (NCSU). After graduating from NCSU in 1975, he went to Mississippi State University to teach statistics in the Business School as an assistant professor, and then returned to his country, Korea, in 1977. Since 1977 he has served as an associate professor and then as a professor of statistics at Seoul National University.

He was the president of the Korean Society for Quality Management as well as the president of the Korean Statistical Society. In 2000, he received the prestigious gold medal from the President of the Korean Government for his contribution to quality management in Korea. Recently, he has served as the Dean of the College of Natural Sciences, Seoul National University.

He is a Six Sigma pioneer in Korea. He has written two books on Six Sigma, and his books are now best-sellers for Six Sigma lovers. He is now the president of the Six Sigma Research Group in Korea. He has also served as the chairman of the evaluation committee for the National Six Sigma Award of the Korean Government. He also participated in APO activities for the promotion of Six Sigma. He became a lecturer for the Symposium on Concept and Management of Six Sigma for Productivity Improvement sponsored by APO, which was held in New Delhi, India, during 7–9, August 2001.

Six Sigma is a company-wide management strategy for the improvement of process performance with the objective of improving quality and productivity to satisfy customer demands and reduce costs. It is regarded as a new paradigm of management innovation for company survival in the 21st century. The initiative was first launched by Motorola in 1987, and with companies such as GE, TI, ABB, Sony, Samsung, and LG introducing their own Six Sigma programs in the mid 1990s, a rapid dissemination of Six Sigma took place all over the world.

This book has three main thrusts. The first gives an overview of Six Sigma, its framework, and the applications. The second introduces the Six Sigma tools, other management initiatives, and some practical issues related to Six Sigma. The third focuses on the implementation of Six Sigma, with real case studies of improvement projects.

Although this book was prepared to give corporate managers and engineers in Asia a clear understanding of Six Sigma concepts, methodologies, and tools for quality and productivity promotion, it will also be useful to researchers, quality and productivity specialists, public sector employees, and other professionals with an interest in quality management.