

CHAPTER 4

Construction Manual of Bio-gas Reactor

4.1 Planning

Criteria for Bio-gas Plant Construction

Family size

- 4.1.1 Farmer who wants to build a bio-gas plant must have animals to sustain the operation of the plant. The minimal number of animals required are :
- | | | |
|-------------------|----------|----|
| Cows or buffaloes | at least | 3 |
| Breeding pigs | at least | 10 |
- 4.1.2 Stationary enclosure which is not more than 20 meters from the bio-gas construction area.
- 4.1.3 Animal should remain enclosure all night or for a minimum of 12 hours.
- 4.1.4 There must be drainage alley connected directly to the bio-gas plant.
- 4.1.5 Access to ground water all year round and the water source should not be further than 20 meters from the bio-gas plant.
- 4.1.6 bio-gas usage should not be placed further than 100 meters from the plant.
- 4.1.7 Farmer and his family members must have interests in using gas, fermented manure and want to build a bio-gas plant to reduce the pollution in environment.
- 4.1.8 Required budget, materials and labour to build bio-gas plant.
- 4.1.9 Time and labour in maintenance bio-gas plant.

4.2 Design of Bio-gas Plant

The fixed dome bio-gas plant buried underground. There are 3 main connecting parts :

- 4.2.1 Mixing chamber:** where animal excrement is mixed with water before it is poured into digester chamber.
- 4.2.2 Digester chamber:** where excrement and water are fermented. Methane and other gases will be produced in the chamber and these gases will push manure and slurry at bottom of the floor into expansion chamber.
- 4.2.3 Expansion chamber:** collects excess manure and slurry. When gas is being used, manure and slurry will flow back into digester chamber to push gas up for usage. When the excess manure exceeds the volume of the chamber, the manure will be drained out.

This system is called dynamic system, when gas is produced inside the pit, the gas pressure will push manure and slurry at the bottom of the pit to flow up into expansion chamber. When this gas is used the slurry in the expansion chamber will flow back into the digester chamber to push the gas up for usage. This happens consistently. The plant will be operated efficiently for a long period of time if the gas pit does not cracked and the system

runs regularly. In each case the strength of the plant depends on fine construction, specification of materials according to the criteria suggested by the Bio-gas Programme, and strict adherence to the instruction manual on the maintenance of the bio-gas.

4.3 Location of the Bio-gas Plant

The plant should not be located further than 5 meters from the enclosure. The digester chamber must be in an open area and should not be near any water source or natural water as animal excrement may seep into underground water. The plant should also be situated on a slope and not on the low land to avoid the danger of floods. The excess manure from expansion chamber should flow into the farmer's field or the storage tank and not into natural water bodies such as rivers to avoid the risk of pollution. **(Figure 4.1)**

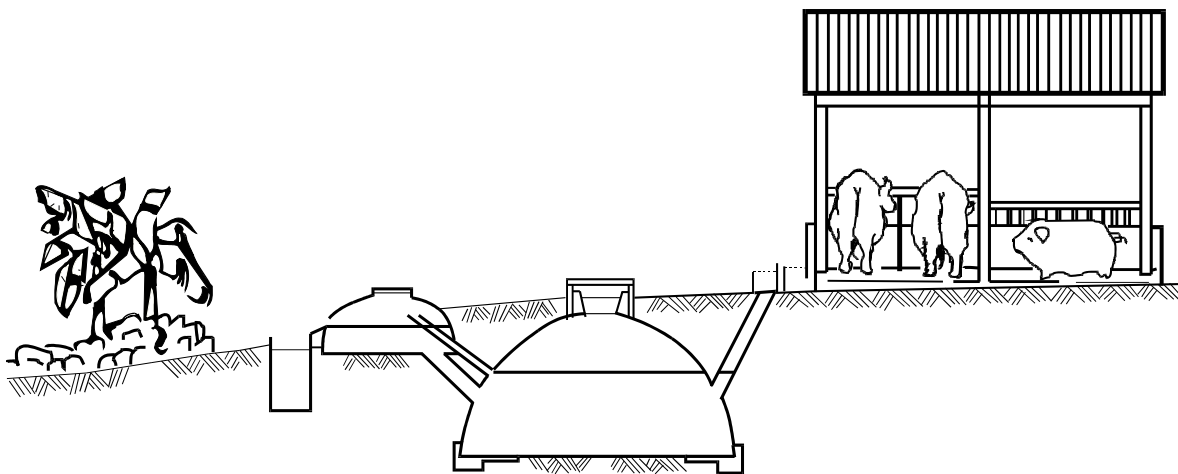

Figure 4.1 Location of the bio-gas plant

4.4 Sizes of Bio-gas that is Suitable for Farms

Consider the following number of livestock needed and the requirement of gas usage.

Livestock	4.6 m ³	8 m ³	12 m ³	16 m ³
Milking cows	2	3	5	7
Meat cows	3	6	12	18
Buffaloes	2	3	8	13
Pigs	10	15	25	38

How to calculate the size of bio-gas plant

Formula Fresh manure/day x amount of animal x 2(for cow/buffalo) or x 3 (for Pig)
x Retention time (60 days)

Example

- Question:** How big should a bio-gas plant be for a farm with 4 cows? (1 cow produces 8 kg of fresh excrement per day)

Answer

Formula animal excrement x number of animal x 2 x retention time

$$8 \quad \times \quad 4 \quad \times 2 \times \quad 60 \quad = 3,840 \text{ kg}$$

** Bio-gas plant should be built at the size of 4 M³*

- Question:** How big is the bio-gas plant for a farm with 45 Breeding pig over 60 kg ? (1 pig produces 2 kg of fresh excrement per day)

Answer

Formula animal excrement x amount of animal x 3 x retention time

$$2 \quad \times \quad 45 \quad \times 3 \times \quad 60 \quad = 16,200 \text{ kg}$$

**Bio-gas plant should be built at the size of 16 M³*

The bio-gas plant must have a concrete slab floor enclosure with a drainage alley with 1 % gradient. If the floor is not on slope, it must be elevated. If animal is being fed outside the enclosure (cows/buffaloes), it must be brought back to stay overnight in the enclosure.

4.5 Fresh Excrement of Animal per Day

1 meat or buffalo produces 8 kgs of fresh excrement per day

1 milk cow produces 15 Kgs of fresh excrement per day

1 pig (over > 60 Kgs) produces 2 kgs of fresh excrement per day

1 pig (< 60 Kgs)) produces 1.2 kgs of fresh excrement per day

200 chickens or 200 Birds, *Bio-gas plant should be built at the size of 1 M³*

4.6 Preparation for Construction

Implements in construction

measurement Tape	Pencil	Saw (wood and steel)
Rope or string	Hammer	Shovel
Axe	Square	Level measurement
Knife	Hoe	Rattan basket
Digger (Figure 2)	Spade	Wheel barrow
Plumb	Sponge	Concrete trowel
Radius stick(Figure 3)	Bucket	Soft broom
Steel trowel	Wooden trowel(Figure 4)	
Brush	Sand paper No 100	
Hard broom	Handles for digester chamber's lid(Figure 6)	
Hose for level control	Mould of digester chamber lid by Thai-German Program standard (Figure 5)	

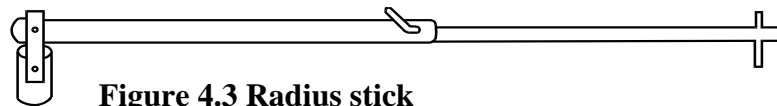

Figure 4.3 Radius stick

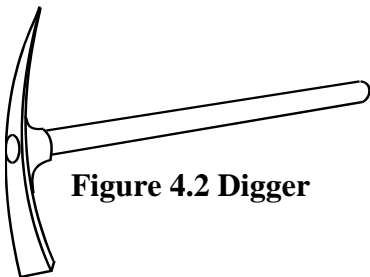

Figure 4.2 Digger

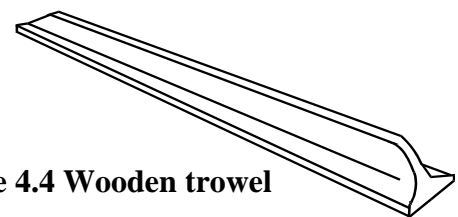

Figure 4.4 Wooden trowel

Figure 4.5 Mould of digester chamber lid

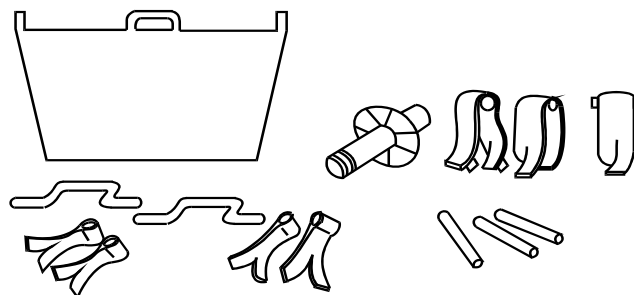

Figure 4.6 Handle for digester chamber's lid

4.7 The Principles of Layout

There are 2 ways of doing layout

4.7.1 Locate the lowest point of drainage alley and mark 30cm above this point. Mark a peg on the opposite side and balance the level between the peg and the mark over the alley with level adjusting hose. Tie temporary reference string between these 2 marks, mark out the center on the level line far from the enclosure at least

2.50 meters	➤	4.6 m ³	3.50 meters	➤	↔± m ³
2.70 meters	➤	8 m ³	4.00 meters	➤	↑± m ³
3.00 meters	➤	12 m ³	4.50 meters	➤	↔± m ³
3.30 meters	➤	16 m ³			

From the mark on the level line, set the center of digester chamber on the ground surface by using plumb. Draw the line to mark the size of digester chamber. Consider the suitable location by using radius (**Figure 4.7**)

1.55 meters	➤	4.6m ³	2.80 meters	➤	↔± m ³
2.01 meters	➤	8 m ³	2.25 meters	➤	↑± m ³
2.24 meters	➤	12 m ³	3.80 meters	➤	100 m ³
2.30 meters	➤	16 m ³			

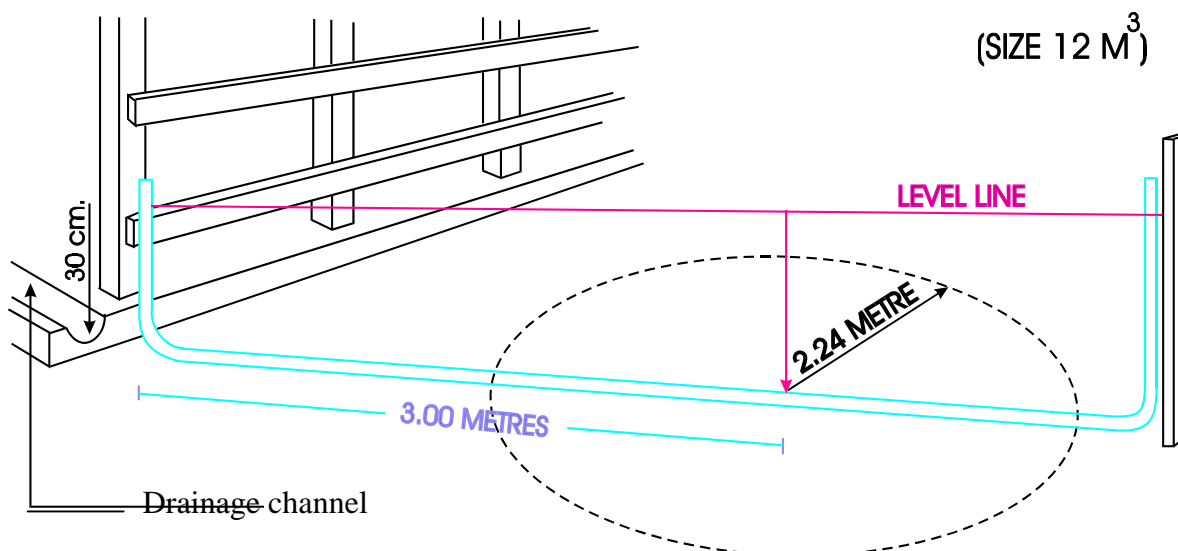

Figure 4.7 Principles of layout

4.7.2 To locate the storage tank, measure from the center of digester chamber

2.90 meters	➤	4.6m ³	5.70 meters	➤	30 m ³
-------------	---	-------------------	-------------	---	-------------------

3.95 meters	➤ 8 m ³	7.04 meters	➤ 50 m ³
4.10 meters	➤ 12 m ³	8.03 meters	➤ 100 m ³
5.22 meters	➤ 16 m ³		

Find the lowest point to set the outlet point which is 60 cm lower than the level line and at least 15 cm over the ground to prevent the outside water to flow into the chamber. If the lowest point can not be located, check the drainage alley for the possibility of being elevated or excavated. When the outlet point is found, the temporary level line becomes level line. Cross another permanent level line to the first line at the center of the digester chamber to locate the center of digester chamber. Set the center of expansion chamber far from the center of digester chamber and mark with a peg.

2.50 meters	➤ 4.6m ³	4.40 meters	➤ 30 m ³
3.00 meters	➤ 8 m ³	5.36 meters	➤ 50 m ³
3.00 meters	➤ 12 m ³	6.16 meters	➤ 100 m ³
3.50 meters	➤ 16 m ³		

The location of expansion chamber should be on the opposite side of the mixing chamber or not over 45° as shown in picture (**Figure 4.8**)

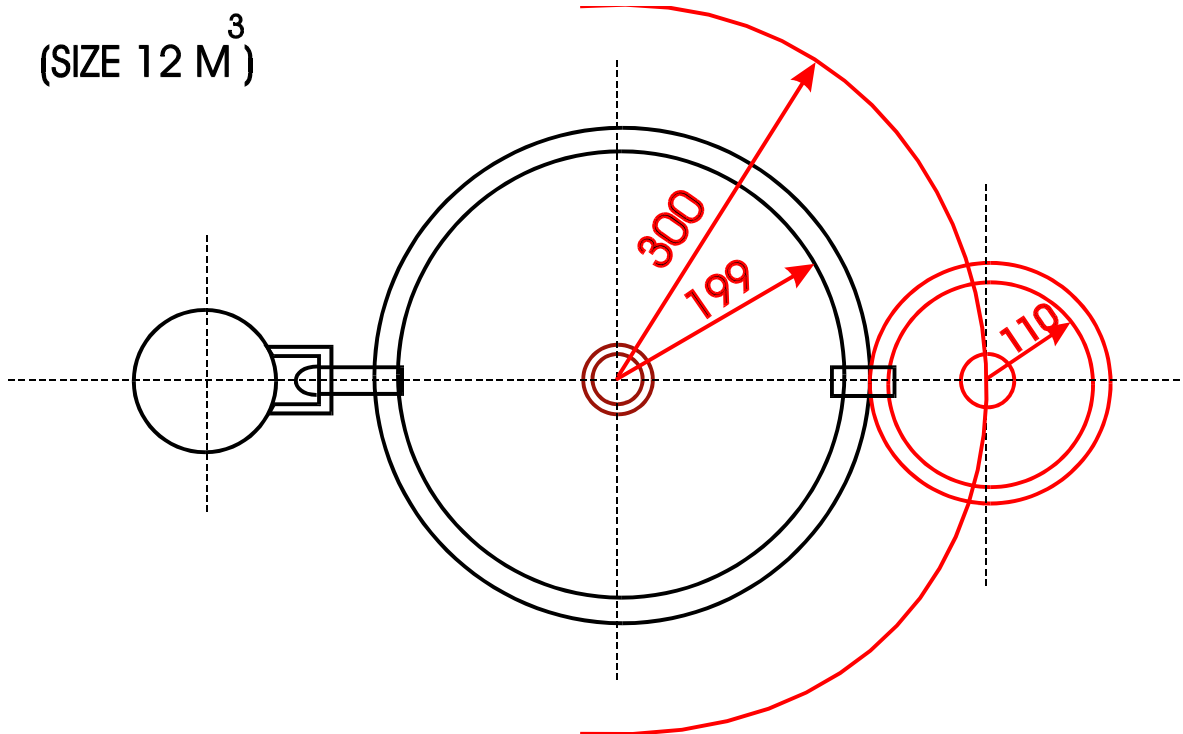

Figure 4.8 The location of expansion chamber

4.7.3 Think before excavating

Ensure that the diameter of the pit is excavated consistently with diameters begin equal at the top and the base, and at depth below level line as suggested below:

2.10 meters	➤	4.6m ³	3.13 meters	➤	30 m ³
2.39 meters	➤	8 m ³	3.82 meters	➤	50 m ³
2.42 meters	➤	12 m ³	4.10 meters	➤	100 m ³
2.67 meters	➤	16 m ³			

Place excavated soil 50 cm away from the edge of the pit and do not put it on the ground where the expansion chamber, mixing chamber or outlet pipe will be constructed. It is a waste of time to have to remove this pile of soil later.(Figure 4.9)

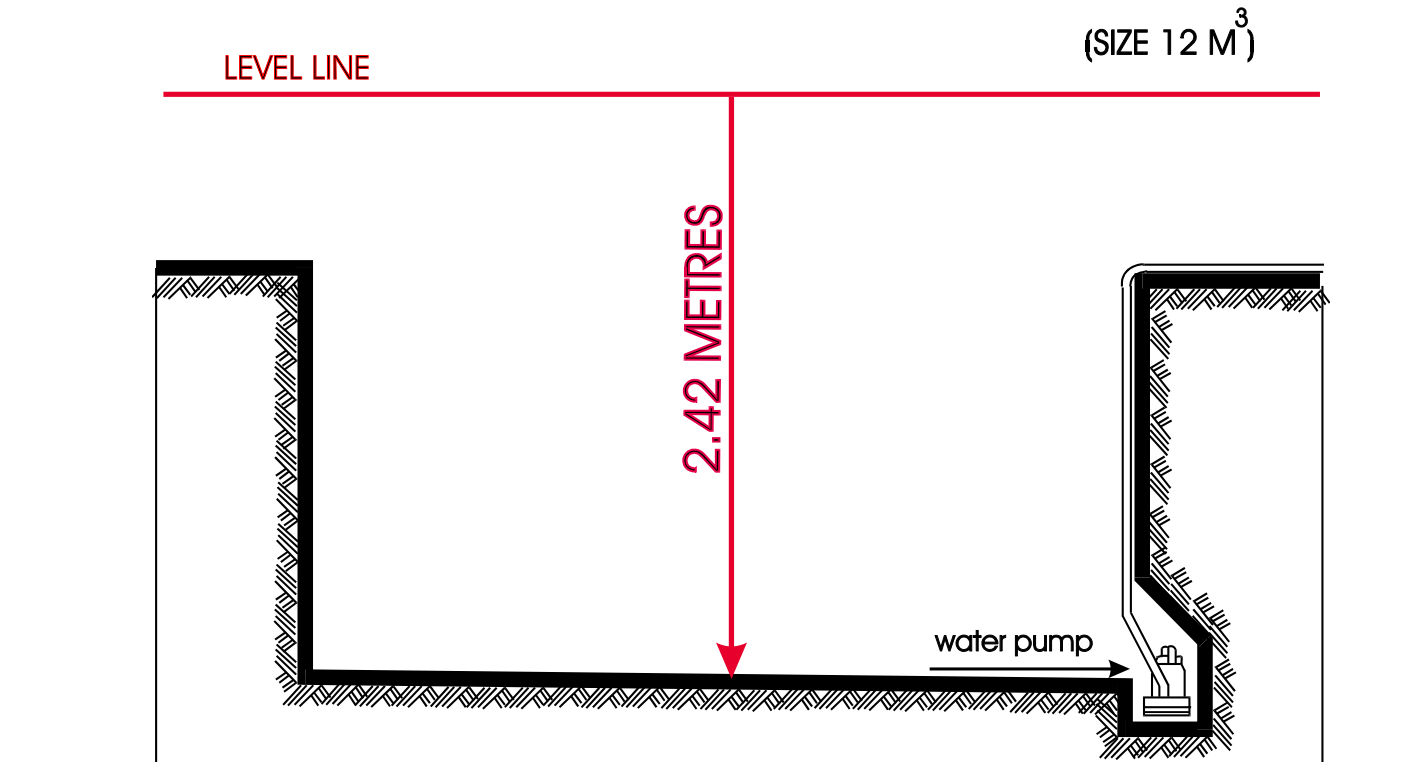

Figure 4.9 Excavating soil

Caution

Do not excavate deeper than suggested as the base of the chamber may not be strong enough. If there is any seepage, a small trap pit must be dug next to the outer edge of digester chamber base. The floor of the trap pit should be lower than the digester chamber so that ground water can flow into the trap pit.

When the required final depth is obtained, set the center at the base of digester chamber by crossing the level line and use a plumb to locate the center of the digester chamber. Draw 2 circles with the following radius

<i>Inner radius</i>	1.15 meters	and	<i>outer radius</i>	1.45 meters	➤	4.6 m ³
	1.46 meters			1.76 meters	➤	8 m ³
	1.70 meters			1.99 meters	➤	12 m ³
	1.94 meters			2.24 meters	➤	16 m ³
	2.43 meters			2.73 meters	➤	30 m ³
	2.90 meters			3.20 meters	➤	50 m ³
	3.50 meters			3.85 meters	➤	100 m ³

Excavate soil in the outer circle to a depth of 25cm deep and draw another circle of radius

0.85 meters	➤	4.6 m ³	1.98 meters	➤	30 m ³
1.01 meters	➤	8 m ³	2.55 meters	➤	50 m ³
1.25 meters	➤	12 m ³	3.05 meters	➤	100 m ³
1.50 meters	➤	16 m ³			

Excavate soil in the inner circle to a depth of 5 cm deep (Figure 4.10)

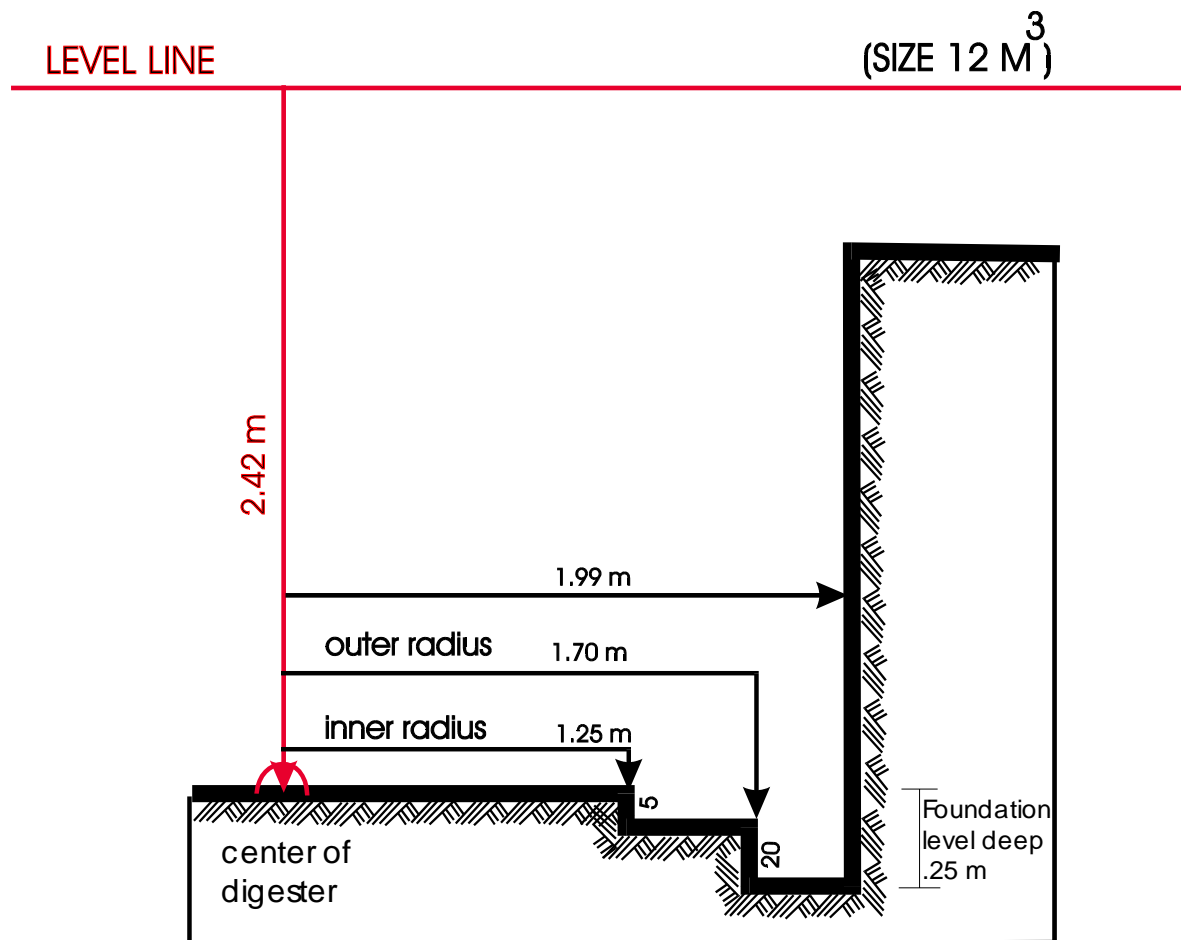

Figure 4.10 Excavate soil in the inner & outer radius